

## **From white elephant to Nobel Prize: Dennis Gabor's wavefront reconstruction**

Sean F. Johnston\*

### **Abstract**

Dennis Gabor devised a new concept for optical imaging in 1947 that went by a variety of names over the following decade: holoscopy, wavefront reconstruction, interference microscopy, diffraction microscopy and Gaboroscopy. A well-connected and creative research engineer, Gabor worked actively to publicize and exploit his concept, but the scheme failed to capture the interest of many researchers. Gabor's theory was repeatedly deemed unintuitive and baffling; the technique was appraised by his contemporaries to be of dubious practicality and, at best, constrained to a narrow branch of science. By the late 1950s, Gabor's subject had been assessed by its handful of practitioners to be a white elephant. Nevertheless, the concept was later rehabilitated by the research of Emmett Leith and Juris Upatnieks at the University of Michigan, and Yury Denisyuk at the Vavilov Institute in Leningrad. What had been judged a failure was recast as a success: evaluations of Gabor's work were transformed during the 1960s, when it was represented as the foundation on which to construct the new and distinctly different subject of holography, a re-evaluation that gained the Nobel Prize for Physics for Gabor alone in 1971. This paper focuses on the difficulties experienced in constructing a meaningful subject, a practical application and a viable technical community from Gabor's ideas during the decade 1947-1957.

---

\* Rutherford-McCowan Building, Crichton Campus, University of Glasgow, Dumfries UK, DG1 4ZL (s.johnston@crichton.gla.ac.uk). The author acknowledges the support of this work by grants from the British Academy, Friends of the Center for the History of Physics of the American Institute of Physics, the Carnegie Trust for the Universities of Scotland, the Royal Society and the Shearwater Foundation. The following abbreviations are used: SM, Science Museum library Gordon Rogers papers (London, UK); MM, MIT Museum archives of the New York Museum of Holography (Cambridge, MA); IC, Imperial College archives, Gabor papers (London, UK)

## 1. INTRODUCTION

In September 1948, the *New York Times* carried the first ever news story about the ‘hologram’:

### NEW MICROSCOPE LIMNS MOLECULE

#### **Britons impressed by paper combining optical principle with electron method**

BRIGHTON, England: Sir Lawrence Bragg, Nobel prize winner in physics, said today that he had been moved from incredulity to admiration of the ingeniousness of the new super-microscope that was described here to the physics section of the British Association for the Advancement of Science.

Dr. D. Gabor, Hungarian scientist, now working for the British-Thomson-Houston electrical engineering concern, explained how by combining the electron microscope with a new optical principle it could be made to resolve the pattern of atoms in the molecule or the details of a virus.

Introducing his new principle of "wave-front reconstruction", Dr Gabor said the electron microscope had reached its technical limit [...]. His new device, which he called a "diffraction microscope", gets around this difficulty by a two-step process. In the first an electron photograph, which he calls a "hologram" is taken. This has no visual resemblance to object under examination. In the second step, the likeness is restored by a reconstruction, or synthesis, carried out with light waves.

The electron part of the diffraction microscope is still only in the paper stage. This is an engineering problem to produce a pinpoint beam. Dr. Gabor, however, demonstrated the optical part and convinced physicists of the validity of the wave-front reconstruction principle.<sup>1</sup>

The news item captured what was to be the peak of popular awareness about holograms for the next sixteen years. The moment in time was flanked by an energetic run-up and a slower decline. When Dennis Gabor had devised his new concept for optical imaging the previous year, it was a tentative and uncertain scheme to improve the limitations of one of his company's products. Over the next decade, the evolving method went by a variety of names: holoscopy, wavefront reconstruction, interference microscopy, diffraction microscopy and even Gaboroscopy, reflecting changing evaluations of its content and purpose. And Gabor, a well-connected and creative research engineer, worked actively to publicise and exploit his concept, marshalling influential mentors, mounting public demonstrations for peers, publishing in scholarly journals, obtaining research grants and collaborating in experimental verifications.

Yet the scheme failed to capture the attention of many researchers or to generate any commercial interest. Despite his strong and varied efforts to promote it, Gabor's theory was repeatedly deemed unintuitive and baffling; the technique was appraised by those who investigated it to be of dubious practicality and, at best, constrained to a narrow branch of science. By the late 1950s, Gabor's subject was judged by its handful of practitioners to be a white elephant. Nevertheless, the concept was later rehabilitated. The research of Emmett Leith and Juris Upatnieks at the University of Michigan, and Yury Denisyuk at the Vavilov Institute in Leningrad, transformed evaluations of Gabor's work during the 1960s, and he was to win the Nobel Prize in Physics alone for it in 1971.<sup>2</sup> Part of Gabor's concept was reused, generalized and repackaged for a new generation of practitioners. What had been judged a failure and dead-end was recast as the basis of a burgeoning research field.

Creating a new science is seldom a one-man job, nor do clever ideas necessarily succeed. This paper recounts Gabor's fostering of 'wavefront reconstruction' not to vaunt the

achievements of a neglected pioneer – which is what his Nobel Prize, in effect, accomplished for a different audience – but rather to probe how new subjects, and their histories, become established. The clarity of hindsight is a familiar aphorism, but identifies a psychological and analytical mirage: like many episodes in the history of science, Gabor’s work appears less orderly and decisive on close examination. Later practitioners rehabilitated Gabor’s reputation retrospectively during the mid 1960s because his work could be represented as the foundation on which to construct their new, and distinctly different, subject of holography. Had that subject been differently configured, Gabor’s historical relevance might have been differently assessed. This paper is not, therefore, intended to judge objective success or failure: instead, it focuses on the difficulties experienced in constructing a meaningful subject, a practical application and a viable technical community from Gabor’s ideas during the decade 1947-1957.

## 2. CONTEXT OF DEVELOPMENT

Like many of his generation, Gabor had had a fertile but unsettled early career. Gábor Dénes (to use his national style of address) was born on 5 June 1900 in Budapest, Hungary. He served briefly with the Hungarian artillery in northern Italy during the First World War, and started his higher education at the Engineering University just as the First World War ended in late 1918.<sup>3</sup> Gábor was of Jewish origin although brought up, as he was later to write to a magazine editor, in an “anti-religious atmosphere [...] at a time when the young middle class of that country fell passionately in love with western thought”.<sup>4</sup>

Gábor continued his studies at the Technische Hochschule Berlin-Charlottenburg, obtaining a Diploma in Electrical Engineering in 1923. The following year he started work there for a Doctorate in Engineering, with research focusing on the construction of one of the first high-voltage, high-speed cathode ray oscillographs, which he used to study electrical transients in power transmission lines. Upon receiving his degree in early 1927, Gábor joined Siemens & Halske A.G., Berlin, the pre-eminent German electrotechnology company, working on the development of high pressure vapor lamps.

With the political rise of Adolf Hitler, Gábor began looking for other employment in 1932. He left S&H in 1933 soon after Hitler came to power, returning to Budapest for a year to work on his own invention, a new design of gas discharge lamp. In 1933-4 he approached three British companies, Associated Electrical Industries (AEI), Metropolitan Vickers (‘Metrovick’) and British Thomson-Houston (BTH). Both BTH and Metrovick were, in fact, sister companies under the AEI umbrella, and were to be important to him in his subsequent career. During the early 1930s, the Metrovick portion of AEI was concerned mainly with heavy engineering, so upon Gábor’s contact with an acquaintance at AEI, manager T. Edward Allibone, he was recommended to the research director at BTH. Gábor anglicized his name, reached an inventor’s agreement with BTH and later became a full-time employee of the Rugby, England, firm researching a variety of projects.<sup>5</sup>

Dennis Gabor’s background and environment shaped his intellectual horizons. The AEI group was unusual in having laboratories dedicated to long-term research. Consequently, Gabor was fortunate to interact with a diverse collection of researchers having disparate backgrounds while maintaining his contacts with émigré scientists from continental Europe. During the Second World War he was classified as an Enemy Alien and excluded from war work at BTH, notably development of the magnetron tube used for radar. He worked in a hut outside the security fence at the firm. Nevertheless, “a continuous stream of colleagues poured into the hut to derive inspiration from his fertile mind”, recalled his friend Allibone years later.<sup>6</sup>

Because he was deprived of security clearance, Gabor was also privileged in escaping research and development on short-term piece-meal military work and to apply himself to projects with longer lead times to be polished after the war. Because such projects were never brought to commercial fruition, Gabor also escaped the relative drudgery of production engineering.

As the company shifted back to civilian products at the end of the war, Gabor found his work gaining more attention. He later recalled that his three post-war years at BTH were a period of “intense and happy activity” during which he worked with his “friend and collaborator” Ivor Williams on three lines simultaneously. The projects had foundations in electrical and optical theory and in practical invention, suggesting his range and depth alongside repeated commercial misfortune:

The first was frequency compression, a first, still incomplete but promising realisation of the principle which I found in my theoretical work. The second was an outlet for the inventor, three-dimensional cinematography. Just before the war, that great enthusiast and successful businessman, Oscar Deutsch, gave an address at a BTH dinner, giving us a vision of the cinema of the future, which had to be of course 3-dimensional. The Director of Research, the late Sir Hugh Warren, encouraged us to “exercise our minds” on the problem. With I. Williams I produced by 1948 what I think was quite an impressive show. But Oscar Deutsch had died in the meantime, and it was decided not to pursue the subject further [...]

My third and last scheme in the BTH was “microscopy by reconstructed wavefronts”. In 1927 I had missed a wonderful opportunity for starting electron microscopy on the ground floor. Twenty years later I wanted to come back to it, and make the instrument realise its full potentiality; the resolution of atomic lattices. Electron lenses could not be corrected. My idea was to break off the imaging process with electrons at a point where the picture was unintelligible, but contained the full information, and finish it by light optics, correcting the aberrations of the electron lenses by optical lenses. The results were spectacular, but it turned out that the ultimate aim could not be achieved.<sup>7</sup>

Thus, from the vantage point of 1961, Gabor’s most creative undertakings during the post-war years at British Thomson-Houston appeared to have been dead ends.

The last of Gabor’s post-war BTH projects grew from ideas for improving electron microscopes. His PhD project, the cathode-ray oscillograph and the magnetic lens system at its heart, had in fact been cannibalised by others to construct the first electron microscope a few years after he left Germany.<sup>8</sup> Such microscopes were modeled on their optical analogs. In a transmission electron microscope, electrons are accelerated through a vacuum and focused on the microscope sample, which absorbs or scatters them and, when focused by a second magnetic lens, creates an image on a photographic plate or fluorescent screen. The advantage of such devices was that – as first established in the 1920s – such fast-moving electrons can be considered as waves having a wavelength some one-hundred thousand times shorter than that of visible light. In principle, electron microscopes can therefore yield images having correspondingly higher resolution. Where optical microscopes are limited to a spatial resolution of some 200 nanometers (nm), transmission electron microscopes of the early 1940s could resolve features of about 5 nm or, in the measuring units of the day, 50 angstroms (Å).<sup>9</sup> Despite this clear advantage, the developers realized that electron microscopes could be much better. The ratio of wavelengths is some  $10^4:1$ , and resolution would be well below 0.01 nm if electron lenses could be designed that were as effective as glass lenses.

Stinging at his lost opportunity to have invented the first electron microscope, Gabor

was interested in contributing to its further development in England. Since 1943, he had consequently been in close communication with Michael W. Haine of Metropolitan Vickers, BTH's sister firm under the AEI umbrella. Haine was working on the development of a commercial electron microscope, and Gabor proffered various ideas on how to improve their design. Gabor wrote *The Electron Microscope* on the still-new instruments in 1944, concluding it with a chapter entitled "The ultimate limit of electron microscopy".<sup>10</sup> Over a period of four years, the two developed a closer working relationship. When Haine moved to the new AEI lab in Aldermaston, their correspondence continued. There Haine and his colleagues carried out experiments and development with occasional suggestions from Gabor. In early 1947, however, Gabor devised a novel approach that he believed could improve the imaging of electron microscopes significantly.

### 3. DEVELOPMENT OF CONCEPTS

#### 'Holoscopy'

Gabor conceived the scheme, according to his own account, while waiting for a tennis court at Easter 1947.<sup>11</sup> On the other hand, Gabor much later pushed back the origins of his ideas, recounting them as a lifelong query:

I first became interested in the problems which ultimately led to holography a long time ago, at the age of seventeen, when I had learned about Huygen's Principle, and read Abbe's Theory of the Microscope. I asked myself a question:- "When we take a photograph, the image appears in the plane of the plate. But by Huygen's Principle the information which goes into the image must be there in *every* plane before the plate, also in the plane before the lens. How can it be there in that uniform whiteness? Why can we not extract it?" Of course I said, white light is a complete jumble. But could we not do it at least with monochromatic light?<sup>12</sup>

Gabor was familiar with recent thinking about such questions, which conceived of separating the imaging process into two stages: one to record, and the other to reconstitute, the image. Others, notably the Polish physicist Miecislav Wolfke in 1920 and Sir Lawrence Bragg from 1939, had imagined a two-step imaging technique using x-rays as the first step and visible light as the second. Indeed, the idea of dividing the imaging process into two parts – an optical transformation, followed by a second transformation to form the image – had been used as a conceptual convenience by the German microscope designer Ernst Abbe in the late 19<sup>th</sup> century. Wolfke, who had been one of Abbe's doctoral students, realized that this process could pay dividends if implemented physically. If x-ray and visible wavelengths were used in the two stages, there would be an inbuilt magnification of about 10,000 owing to the ratio of their wavelengths. However, he also recognized that detectors of visible light – such as photographic plates – recorded only the intensity of light, not its phase. And without information about the phase and amplitude of the light waves, the information in the wavefront of light could not, in general, be deduced.

As hinted in his 1961 recollection above, Gabor also envisaged a two-step process, but using electron waves and light waves. In Gabor's scheme, an electron microscope would be used merely to cast the shadow of the object. That shadow, according to physical optics, would be surrounded by 'fringes' of optical interference, because the electrons themselves, considered as waves having a very short wavelength, would interfere constructively and destructively to yield light and dark regions. The wavefront passing very close to the object would be diffracted, or deviated, towards portions of the wave that were undeviated further away. In this way,

interference fringes would ring the shadow of an opaque object. The first step of the imaging process was to record this interference pattern on photographic film. In effect, the interference pattern would encode information about both the phase and magnitude of the wavefront.

The second step was to mount and illuminate that film in a special optical apparatus. The optical arrangement would cause a beam of visible light to be diffracted by the recorded interference pattern. According to Gabor, this should ‘reconstruct’ a wavefront precisely like the one that originally had recorded the fringe pattern. This reconstructed wavefront would thus recreate an image of the original object. This circuitous and seemingly pointless encoding and decoding of the image would be worthwhile, he argued, because optical lenses could correct for aberrations (image imperfections) created by electron microscope lenses. Electron microscope lenses, unlike optical lenses, could not readily be designed to overcome spherical aberration. This caused an unavoidable smearing of focused images and limited the ultimate resolution attainable. With his two-step ‘wavefront reconstruction microscopy’, however, Gabor suggested that this limitation could be overcome by designing the second half of the system – the optical reconstruction portion – to correct for such defects. Indeed, he hoped that it might be possible to achieve a resolution of 1 Å (0.1 nm), to make it possible to resolve atoms themselves.

The concept that dawned on Gabor at the tennis court took time to refine in terms that others could appreciate. Gabor’s labeling of the new principle, process or technique took time to settle, too. Although he conceived the idea in early May 1947, it took two months for the new Research Director at BTH, L. J. Davies, to approve time to investigate Gabor’s idea. Gabor’s concept of wavefront reconstruction did not immediately appeal to his superiors at British Thomson-Houston. The work appeared to be primarily optical design, while the company specialized in electrical engineering design and electrical products. Gabor and Williams began optical experiments in July, and continued into 1948. Gabor’s intention from the beginning was to perform a feasibility experiment on the optical reconstruction concept and then, if successful, to collaborate with personnel at the AEI Research Laboratory in Aldermaston to work on the electron microscope portion of the two-step process. Gabor intended to liaise with the Director, T. E. Allibone, engineers Jim Dyson and T. Mulvey and have the project overseen by his friend Michael Haine.<sup>13</sup>

From the outset, Gabor’s scheme raised questions. A fundamental concern about the concept was whether the available sources of waves – either the electron beam or visible light – would be sufficiently ‘coherent’. Two wave trains are defined to be coherent if they have the same frequency and phase; in practice, coherence is measured by the ability of two wavefronts to interfere. If two such wavefronts are perfectly coherent (i.e. have precisely the same phase and frequency) they will generate interference ‘fringes’ ranging in intensity from zero to some maximum. Two less coherent wavefronts will generate a washed-out fringe pattern having lower contrast, and non-coherent or ‘incoherent’ light will not generate any visible interference fringes at all.<sup>14</sup>

The coherence properties of the electron beam were not yet well characterised. Even obtaining such a coherent source of *visible* light was difficult enough. To describe a light source as having a well-defined frequency – sometimes referred to as *temporal coherence* – is to say that it is monochromatic. If such light is dispersed by a prism, its spectrum will be seen to consist of a single narrow spectral line. A light source having a well-defined phase (a condition described as *spatial coherence* – is also unusual. It requires that the wave be obtained from a small region, where the wave train is unmixed with others. Spatial coherence measures, in effect, how the light amplitudes at two locations are related to each other. These two requirements mean that an incandescent lamp is highly incoherent. Light from an incandescent lamp consists of a wide range of frequencies, all generated by independent atoms within the hot

filament. Those waves have no constant phase relationship to each other, and the range of frequencies produced depends on the filament temperature. The only light sources suitable for Gabor's concept were akin to neon tubes: gas lamps that generate a series of discrete frequencies or pure colors. If such a lamp were filtered to remove all but one frequency of light, and passed through a pinhole to select one clean wave train, then it could be made reasonably coherent. That is to say, if the wavefront of light were to be divided into two portions, those portions would generate interference fringes when brought together again provided that the difference in the optical paths was not too large – certainly no more than a fraction of a millimeter. This degree of coherence (a property later dubbed the coherence length) was adequate to test Gabor's concept, because the two interfering portions of the wave consisted of light diffracted around the edge of an object and other light proceeding directly to the photographic plate without diffraction. For flat or very shallow microscopic objects, Gabor reasoned that 'wavefront reconstruction microscopy' should generate enough interference fringes to work.

The drawback of creating a coherent light source with optical filters and pinholes was that this arrangement reduces the intensity dramatically. For this reason, Gabor and Williams found their feasibility experiments difficult:

The best compromise between coherence and intensity was offered by the high pressure mercury lamp, which had a coherence length of only 0.1 mm, enough for about 200 fringes. But in order to achieve spatial coherence, we [...] had to illuminate, with one mercury line, a pinhole of 3 microns diameter. This left us with enough light to make holograms of about 1 cm diameter of objects, which were microphotographs of about 1 mm diameter, with exposures of a few minutes, on the most sensitive emulsions then available.<sup>15</sup>

The photographic record of the diffraction pattern, which Gabor dubbed a 'hologram' from Greek roots to denote 'whole picture', was tiny and yielded a reconstructed image that required a microscope for viewing.

Gabor recalled 18 years later, "When I started holography, neither I nor my assistant, Ivor Williams, had any experience in optics, yet we got it going in half a year".<sup>16</sup> Their first image was a chart consisting of black letters on a white background, which they photographically reduced to create a transparent microphotograph. This was then used to create a diffraction pattern, or hologram, which looked like a fuzzy, ringed version of the original. When the hologram transparency was itself put in place and illuminated by the optical system, they found that this illegible transparency miraculously generated an image that could be viewed through a microscope eyepiece. The quality of the image was not as good as the original microphotograph, but was discernibly more legible than the hologram. But the quality of the reconstruction was marred by spurious patterns, and also seemed to depend on how the hologram had been chemically processed to yield a transparency, and how the final photograph was generated (a higher contrast print made it more legible). Moreover, the first half of the proposed instrument – the electron beam that was to generate the hologram – was entirely unexplored. Nevertheless, by the end of 1947 Gabor was encouraged enough by their first results to spread the news to prominent researchers.

In December Gabor visited Cambridge to see Sir Lawrence Bragg, who had made his own reputation from his studies of x-ray diffraction during the First World War.<sup>17</sup> The Braggs' work had revealed a method for inferring crystal structure: they had shown that regular lattices of atoms would diffract short-wavelength light to form a regular series of spots that can be decoded to determine the planes of the crystal. In the early 1940s, Bragg had been extending his work to x-ray imaging. He had recently developed the concept of an x-ray microscope, and

explored a practical implementation.<sup>18</sup> The basic idea of the x-ray microscope was a double-diffraction process. A crystal lattice would diffract x-rays to form a regular pattern of spots that could be recorded on photographic film; that pattern could then be used to diffract light to form an image of the original crystal structure. However, there were severe limitations to this scheme: the x-ray diffraction pattern did not record all the information about the diffracted waves: it saved the *intensity* but not the *phase*. Because of this, the x-ray microscope would work only for objects that affected the phase of the diffracting waves in simple, or calculable, ways. Crystals as a class of objects change the phase in steps a half-wavelength, and there appeared no obvious way for extending Bragg's technique to more general objects.

Gabor's own concept owed some similarities to Bragg's ideas in that both were two-step processes and sought to extend the resolution of spectroscopy – Bragg by employing short-wavelength light rays (x-rays) and Gabor via electron waves. However, Gabor's concept provided more information than did Bragg's, because the diffraction diagram, or hologram, encoded information about not only intensity but also phase. The fringe pattern of the hologram recorded the comparison between the wave diffracted by the object and the original regular wavefront. In Bragg's scheme, only intensity was recorded, and so phase information – which provided spatial information about the relative position of points on the object – had to be inferred by limiting observation to a narrow class of regular objects such as crystal lattices. By contrast, a more general class of irregular objects could be studied by Gabor's holoscope. He described his new concept for microscopy to Bragg and received an encouraging, if not fully comprehending, reception. In mid January 1948 Gabor followed up the visit with a written report on the 'two-step method' of 'electron-microscopical ideas' to Bragg and V. E. Coslett, a researcher pursuing electron microscopy at the Cavendish Laboratory at Cambridge, and for internal circulation at BTH.<sup>19</sup>

Gabor had hinted of his ideas to others even earlier, because electron microscopist J. B. Le Poole wrote to him that January on behalf of the International Commission on Optics, asking for a short article on the optics of electron microscopy for a forthcoming ICO publication and enquiring about "obtaining images from the diffraction pattern according to the method you spoke of in September". Gabor replied two weeks later, providing the requested description of phase contrast in electron microscopy, and added, "As regards the second idea, this is for the time being a very confidential matter, as I have not yet published anything on it. But I have filed a patent, and I am circulating a report on the theory among some British experts.

#### Figure 1: patent illustrations.

I have also carried out some successful experiments, and I think I am near enough to publication to let you have the following short report".<sup>20</sup> What Gabor drafted for Le Poole in February 1948 comprised the first written description of his concept intended for a scientific audience:

#### **Reconstruction of optical images from diffraction patterns obtained with diverging beams ("Holoscopy")**

D. Gabor in 1947 started work on a new line which might lead to a method of electron microscopy with superior resolution. It is a two-step method in which first a diffraction diagram of the object is obtained by means of electrons, from which the original object is reconstructed in an optical apparatus. The general foundation of the new method is, that a wavefront can be reconstructed from any plane which it traverses, if in that plane systems of lines or small patches are marked out in which the phase of the wave coincides with a standard wave, transmission being restricted to those regions of phase coincidence, where it is made proportional to



the intensity of the original by a photographic process. It is only necessary that these lines or patches shall extend over an area corresponding to the required aperture. If now this photograph is illuminated by the standard wave, only those parts of it will be transmitted which coincide in relative phase and in intensity with the original wave, and the original object can be seen. Moreover three-dimensional objects may be recorded in one photograph, hence the suggested name “holoscope” which means “entire” or “whole” vision.<sup>21</sup>

This seems to be the only written reference Gabor made to ‘holoscopy’ and the ‘holoscope’, although his collaborators were later to use the term from time to time. Gabor stuck with the term ‘hologram’, though, and employed it regularly in subsequent publications.<sup>22</sup> The provisional, but so far unpublished, patent specification, drafted a few months earlier in the autumn of 1947, had coined the term ‘hologram’, and also provided a reasonably clear practical description of his idea. Its penultimate paragraph mentioned this most unusual aspect of the invention:

A striking property of the imaging method according to the invention is that every diffraction diagram records the object not only in one plane, but also in depth, thus in the case of objects with appreciable longitudinal extension they can be explored in depth in the viewing device, in just the same way as a deep object is explored under the microscope.<sup>23</sup>

As his first two descriptive texts emphasized, Gabor’s technique was an unfamiliar but powerful form of imaging. It encoded and decoded the image in a two-step process in a way that made it amenable to optical correction or treatment. It also recorded more information than did a conventional photograph. But this was distinctly unlike the three-dimensional imaging that Gabor had already been investigating for television and cinema.<sup>24</sup> It was the apparent recreation of the object’s optical properties seen by one eye through a microscope eyepiece: “viewing the source through the plate, one sees not only the source, but also the object, enlarged in the same ratio. This reconstructed virtual object may be observed or photographed by suitable viewing devices, as known in the art”.<sup>25</sup> There is no hint from surviving documents that Gabor ever linked wavefront reconstruction with stereoscopic imaging before the early 1960s.

Gabor and Williams continued their optical experiments during the spring of 1948, producing a new series of holograms and image reconstructions in May.<sup>26</sup> Gabor maintained a close correspondence with Bragg that year as the most interested and influential outside authority. In March 1948, Gabor sent him “a short report on the first experiments, with some of the results”, requesting that Bragg, as an FRS, read a paper to the Royal Society on his method. Bragg replied ambivalently the next day, “The results are interesting. I must confess I have not thrashed out the theory of them perfectly yet, but I mean to do this when I have a little more time”.<sup>27</sup> Gabor demonstrated his experimental apparatus at the London Conference of the Electron Microscope Group on 7-8 April 1948 and reported to Bragg that it had had “a very satisfactory reception”.<sup>28</sup>

**Figure 2: Gabor poster**

### ‘A new microscopic principle’

Gabor had a short paper published in the May 15 1948 issue of *Nature* that incorporated the work that he and Williams had carried out up to February. The paper was aimed at electron microscopists, and framed in language and orientation that made it unlikely to be noticed by other scientists. The principle that Gabor described was the basis for a visual optical method intended to supplement what were, by then, becoming the conventional practices of electron

microscopy. Such a hybrid system was not likely to appeal either to traditional optical microscopists or to the small but growing community of electron microscopists. While electron microscopy in the late 1930s had recorded images directly on photographic plates, the latest generation of microscopes incorporated fluorescent screens so that the image could be viewed immediately and directly. A two-step process, and particularly one that required photographic processing both in the 'encoding' and 'reconstruction' stages, bucked the developing norms of practice.

The proposed technique did offer some intriguing possibilities, though. Like the earlier patent application and description for the ICO, the paper alluded to the exotic three-dimensional nature of wavefront reconstruction:

It is a striking property of these diagrams that they constitute records of three-dimensional as well as of plane objects. One plane after another of extended objects can be observed in the microscope, just as if the object were really in position.<sup>29</sup>

Gabor highlighted what he saw as a new opportunity for microscopy: a much-improved usable depth of field, in which the image could be observed at leisure after recording. This could be a significant advantage over conventional electron microscopy, which could destroy a sample after extended exposure to electrons. But the putative three-dimensional properties of the technique had not been confirmed because of the inadequacy of Gabor's coherent light source. Furthermore, the paper intimated that the 'new microscopic principle' had been scarcely half-tested: the optical second stage had been verified crudely, and Gabor had not yet done any work on the design of the electron microscope first-stage portion to yield a complete microscopic apparatus. Thus the brief two-page paper failed to excite much interest amongst readers of *Nature*: the technical description was imprecise and yet overly focused on a particular community; it was tentative in its experimental verifications but optimistic in its claims; the eventual method seemed to doom microscopists to a complex, hybrid working culture that grafted optics and photography to electronics; and the principle itself appeared counter-intuitive, suffering from a lack of easily grasped physical insights. It was a principle in limbo: it promised much, but had as yet delivered little.

Hoping to generate more interest from microscopists with a better explanation, Gabor wrote to Bragg again in mid June, still clearly excited by the intellectual and professional possibilities, even if his feelings were not shared within the firm:

As you will see, the previous rather patchy treatment has now been replaced by a straightforward, and I think fairly complete theory. It is of course far from exhausting [sic], but if by any *vis major* I should be prevented to carry out the experimental programme myself, I think experimenters will find in it almost everything they require in the way of guidance.

But I want to do my best to carry out the work myself to its conclusion. It appears that the matter is at the moment *sub judice* at the highest levels of our Company. At any rate I am determined that wherever this work will be going, I want to go with it.<sup>30</sup>

Gabor realized that his explanations of his concept were difficult to digest, and decided that direct demonstrations impressed his colleagues more. He arranged further demonstrations for influential scientists,<sup>31</sup> including his acquaintance the nuclear physicist Rudolph Peierls, to whom he sent a copy of the *Nature* paper along with a note:

The short paper is the first description of a lucky find, which has made me very happy. You need not take the explanations too seriously, this tentative theory was good enough to lead me to the experiment, now I have replaced it by a more complete and coherent one. I have also perfected the experimental arrangement considerably, and now I can produce really pretty reproductions of the original from apparently hopelessly muddled diffraction diagrams [...]. I hope I shall be able to rouse sufficient enthusiasm in competent circles to get the funds necessary for this ambitious program.<sup>32</sup>

And to Bragg he wrote:

In case there should be no opportunity to exhibit the apparatus in operation at the B.A. I will try to get an opportunity to take it with me one day to Cambridge, and demonstrate it to you. It is quite fascinating to see the original object emerge clearly from the hopelessly confused diffraction pattern, and I think you will like it.<sup>33</sup>

Bragg was seduced by Gabor's experimental demonstration of wavefront reconstruction, if not by his written descriptions. He encouraged further demonstrations, writing in July:

I am fascinated by your recent photographs, and am very glad it has been possible to arrange for you to describe them at the British Association meeting. I think I am beginning to understand the principle, though it is still rather a miracle to me that it should work. I shall look forward very much to hearing your account.<sup>34</sup>

Nevertheless, by late July 1948, having read Gabor's draft Royal Society paper more carefully, even Bragg was cautioning that the theory was difficult to absorb and that Gabor needed to make a stronger impact:

I have been trying hard to understand a bit better your very exciting principle, and I think I have made some progress. My difficulty is due to my not having enough time and energy to get down to it properly, not to any lack of clarity in the exposition.

Bragg suggested the *Philosophical Magazine* or *Proceedings of the Physical Society* for the full mathematical treatment, because "To be quite realistic, few people will read it thoroughly, but the work must be on record somewhere".<sup>35</sup> Gabor grudgingly made some cuts, and in a letter a few weeks later Bragg suggested that he not waste time on further revisions until referees had had an opportunity to see it.

### 'Microscopy by reconstructed wave-fronts'

Through such networking, Gabor's concept came to the attention of a wider circle of scientists during late summer of 1948. His redrafted 33-page paper, presented to the Royal Society by Bragg on Gabor's behalf in late August 1948 and published after further revisions six months later, explored possibilities at much greater length. Here the term *hologram* again made an appearance, although 'holoscopy' had been retired in favor of the ungainly phrase 'microscopy by reconstructed wavefronts'.<sup>36</sup> Bragg had also been able to find a late slot for Gabor's demonstration at the September annual meeting of the British Association for the Advancement of Science (BAAS) in Brighton.<sup>37</sup> This brought Gabor's technique to its widest audience and produced the most public result, the *New York Times* article that opened this paper.

That autumn, with the extended paper and the British Association meeting under his belt, Gabor returned to the larger project of developing the *system* of wavefront reconstruction.

This project, as he had originally planned, divided neatly into two parts: the electron microscope experiments to produce a good diffraction pattern would be performed by Michael Haine and his colleagues at AEI, working under T. E. Allibone; and, the optical ‘reconstruction’ apparatus, which he dubbed an ‘optical synthesizer’ [sic], would be designed at BTH by Williams and himself, probably with assistance from T. Smith, a former optician at the National Physical Laboratory recommended by Bragg.<sup>38</sup> Allibone helped arrange generous funding for the AEI portion by the Department of Scientific and Industrial Research (DSIR) – an unprecedented development, because the DSIR had never previously awarded a contract to an industrial company. The grant was presumably motivated by the government’s wish to help promising British technological exports during the difficult post-war period – and the electron microscope was a promising technology.

Thus, in the space of fifteen months, Gabor had conceived a new imaging concept, had convinced his company administrators to support brief experimental tests, and had then promoted his results to an influential mentor (Sir Lawrence Bragg) and a widening collection of microscopists. With his energetic promotion and the influential endorsements of Bragg and Allibone, Gabor had published two papers, demonstrated the optical principle at the BAAS, and gained newspaper coverage and DSIR support. Together, these developments added up to new opportunities both for wavefront reconstruction and Dennis Gabor himself.

**Figure 3: Gabor in middle age**

## The diffraction microscope at Imperial College

Wavefront reconstruction became a key factor in improving Gabor’s career prospects. As early as 1947, he had been beginning to look for fresh pastures. The war over, many colleagues were again on the move: back to continental Europe for some émigrés, and to America for others. Post-war Britain was a country of shortages – of labor, money, raw and finished materials and, not least, of paper for publications. Gabor had spent 12 years in the BTH Research Laboratory on a variety of projects. To his regret, and limiting his career aspirations, none of the projects had been commercialized.<sup>39</sup> Now in his late forties and with a record of fertile but unmarketed ideas, Gabor was seeking new opportunities.

Gabor had sought the advice of his friend Allibone as early as May 1947 – within days, in fact, of conceiving wavefront reconstruction – that he was thinking of leaving BTH. Until then, Gabor had believed the company to be the best place to develop his ideas of a stereoscopic cinema system, but he now realized that resources there were inadequate for such a big project. More positively, he noted that the British government’s Post Office Laboratory had shown interest in his work on communication theory, and was eager to pass on news about his fascinating idea for improving electron microscopes.<sup>40</sup>

So over a year later, in the midst of his first successes with wavefront reconstruction, Gabor was primed to exploit the concept. In July 1948, when he was finalizing his Royal Society paper with Bragg, Imperial College in London published an advertisement for a new position, the Mullard Readership in Electronics. Gabor sounded out his friends, who unanimously advised him to apply for the post; within days he drafted an application. His latest work, which he was now thinking of as the ‘Diffraction Microscope’, clearly played a large part in his planned move. His initial confidantes about the career decision were people to whom he had first confided his concept. Bragg, Allibone and Prof S. R. Milner, all Fellows of the Royal Society, provided references.

Gabor wrote to the Head of Electrical Engineering at Imperial and member of the selection panel, Prof Willis Jackson, about his aptitude for the post. The letter reveals candidly Gabor's unusual professional strengths as well as his hopes for wavefront reconstruction as a concept, and the diffraction microscope as its implementation:

If it is desired that the Imperial College should turn out engineers who, for instance, can be put straightaway on the development of time circuits, without having Puckle's book at their elbow, I am definitely not the man for the job. I have designed every screw in my sound compressor myself, and I made quite a bit of it with my own hands, but I left the whole amplifier to my laboratory assistant, because I knew that he could copy it quite well out of the *Wireless World* and *Radio Handbooks*.

What I could teach is first principles, electromagnetism, electron dynamics, circuit dynamics, gas discharges, and what I do not know, such as feedback theory, servo systems, radar, I could learn. But I am afraid I am no longer young enough to learn the practical details. Ever since I left the University I have crammed more and more fundamental stuff in my head, more mathematics, more physics, and when it came to practical research, I could get from first principles very quickly down to the details. Of course there were always people around me who knew the routine stuff which I did not know [...]

And most important of all, there is the new project of the electron diffraction microscope. I think I ought to inform you in confidence on the plans which are now beginning to take shape.<sup>41</sup>

Gabor was duly offered the post and, with it, the opportunity to pursue wavefront reconstruction. His new work was also accelerating. The diffraction microscope and a growing circle of influential acquaintances offered new career opportunities and research directions for Gabor. He intended to continue the diffraction microscope research project with AEI via the DSIR grant, and the speech compression project with BTH, especially since it reflected the electronic theory aspects of his new post. At age 48, he was running at full steam.

Thus the story of wavefront reconstruction through its conception in 1947 and promotion through 1948 was that of a single protagonist, Dennis Gabor, moving between industrial and academic science and supported by an influential ally, Sir Lawrence Bragg. But over the next year and through the following decade, a handful of other investigators took up the subject and extended it in new directions. By the autumn of 1950, when Gabor had been in his Imperial College post for nearly two years, he wrote to his friend C. R. Burch at Bristol University that, despite having most of his time occupied with the writing of his lecture courses, and "getting a laboratory going with totally inexperienced young people", a flurry of publications had demonstrated that others were taking an interest. Scientific papers by Bragg, his AEI co-workers, and another British physicist, Gordon L. Rogers, had appeared next to his own in a recent issue of *Nature*.<sup>42</sup> Gabor had also heard of interest at Stanford University in California. The beginning of the 1950s looked promising indeed for wavefront reconstruction as a theoretical domain and practical application.

#### 4. EXPANDING INTEREST

##### Gordon Rogers and 'D.M.'

Apart from his associates at AEI, Gabor was to interact most closely on wavefront

reconstruction with Gordon Rogers (1917-). During the spring of 1948, during his first efforts to publicize his new work, Gabor had given a colloquium on wavefront reconstruction at University College Dundee attended by Gordon Rogers, who was a lecturer there.<sup>43</sup> As a former PhD student of Sir Lawrence Bragg, Rogers was familiar with current research on improvements to microscopy, particularly Bragg's concept of an x-ray microscope. Rogers had done experimental work on the x-ray microscope, and also had tried to develop stereoscopic x-ray imaging, and was an ardent amateur photographer.<sup>44</sup> As such, he was unusually positioned to provide useful comments on Gabor's internal report. He also gave Gabor advice on using cine camera objectives instead of microscope objective lenses, and recommended improvements to Gabor's photographic technique, the choice of optical filters and photographic emulsion, and chemical processing to improve the photographic contrast.<sup>45</sup> Rogers was again in direct contact with Gabor about wavefront reconstruction (or specifically diffraction microscopy, which he habitually abbreviated 'D.M.') from November 1949, writing that he had been "working hard" since reading Gabor's *Proceedings of the Royal Society* paper two months earlier.<sup>46</sup>

Rogers made three important contributions to the nascent subject of wavefront reconstruction: first, he provided a simpler and more general description of wavefront reconstruction than had Gabor; second, he published a detailed account of his experiments, which made it easier for others to repeat and extend them;<sup>47</sup> and third, he collaborated directly and enthusiastically with other researchers interested in extending the technique.

But while Rogers became intrigued by the possibilities, he was critical of Gabor's general understanding and formulation of wavefront reconstruction. In particular, Rogers gradually conceived a link with physical optics that Gabor had not noted: he realized that the hologram could be understood as a generalized Fresnel zone plate. A zone plate is a bull's-eye-shaped pattern of alternately opaque and transparent concentric circles designed so that the edges of the black circles diffract light toward the optical axis where they combine constructively to yield a bright spot. In fact, this unintuitive pattern acted much like a glass lens, producing a focused image and an unfocused 'virtual' image, a characteristic that hindered the image quality of Gabor's holograms.

#### Figure 4: zone plate

Such optical patterns had been observed in many circumstances before, although the physical requirements were uncommon and the explanations were not always generalized.<sup>48</sup> Bragg, for example, wrote to Gabor in 1948 about "pheasants' eyes", for which he had "a vague idea that they are due to minute faults in the microscope lenses, which show up very much more when one is dealing with light from a point source".<sup>49</sup> These spurious diffraction patterns, claimed Gabor, were due mainly to dust particles and imperfections in the optical components used to record the holograms.

While zone plates were discussed in most optical textbooks of the period, they usually served as merely a demonstration of the phase and diffractive properties of light that are important in physical optics. Most of them described a single readily observed experimental fact: that the zone plate produced a bright focus from a collimated light source because the diameters of the circles of the zone plate are such that the diffracted light arriving at a particular point on the optical axis in phase, producing a bright focus. Less frequently reported in optics texts was that such a pattern acts not only as a positive lens (yielding the 'real' focused image) but also as a negative lens (yielding a virtual image seeming to emanate from a point ahead of the zone plate) for a monochromatic beam of light. These two images correspond to Gabor's primary and conjugate images produced by the hologram, and could be generated by a single point at the object position of the diffraction microscope. Indeed, Rogers came to understand during 1949

that the hologram itself is merely the superposition of many such zone plates to yield focused points that reconstruct the points comprising the image. His first publication on the subject was a brief note in *Nature*.<sup>50</sup> Nevertheless, this was an insight that developed gradually. Not until April 1950 did he record his realization that a hologram obeys the lens formula.<sup>51</sup> Rogers also struggled to extend the description of the zone plate itself, especially the fact that ‘conventional’ zone plates described in optics textbooks produced not just two foci, but a whole series.<sup>52</sup> Later still, he and others convinced themselves that the zone plate was not merely an ‘analogy’, but the simplest case of a general relationship. Albert Baez, the following year, and Hussein El-Sum, in his PhD thesis of 1952 (both described below), painstakingly verified such optical relationships by experiment. This generalisation required the mapping of concepts of information theory, or at least Fourier analysis, onto physical optics. While such concepts had a long history of interconnection going back to the late nineteenth century and the work of Albert Michelson in America, Lord Rayleigh in England and a series of French investigators, they were not familiar to many practising optical scientists in the mid twentieth century. Gabor admitted that he had come to similar conclusions only in 1950:

It is rather queer that it did not occur to me earlier that the hologram acts like an optical system, seeing that we have made use of this property in our experiments, when we illuminated it in the reconstruction from a distance different from that used in the taking. But now we are making conscious use of it.<sup>53</sup>

Rogers continued to communicate closely with Gabor through the early 1950s, providing intellectual incentive and critiques to refine Gabor’s own ideas. During 1950, stymied by lack of progress at AEI in creating electron holograms, they considered applying wavefront reconstruction as a means of improving optical microscopy; Gabor eventually won grant money from the Royal Society Paul Instrument Fund.<sup>54</sup> They also began to have misgivings about whether a single hologram could truly record the complete image, or whether two were required.<sup>55</sup> Over the next couple of years Gabor, with assistant W. P. Goss at Imperial, and Rogers alone at Dundee, pondered a variety of optical schemes to reconstruct a complete image untainted by an unfocused twin image.<sup>56</sup> To promote this open collaboration further, Gabor tried, but failed, to obtain a post for Rogers at AEI.<sup>57</sup>

Rogers also kept up a close correspondence with Bragg about progress in implementing the diffraction microscope, and collaborated on a paper that proposed an alternate solution to the twin image problem. As its introduction explained, his idea was to make a second hologram of the conjugate image and to subtract it optically from the original by placing the two holograms in contact.<sup>58</sup> However, the great precision required to register them proved problematic, and the twin image could not be removed entirely

Through this period, Gabor, Rogers and Bragg held out hopes that with such fixes a practical implementation of the diffraction microscope could be achieved and even commercialized. Writing to Gabor in 1951, Rogers asked:

Has anyone tried to “sell” the thing, and if so have you got patents on reconstructors!! I should also be interested to know how your young man is getting on with your microscope with the quadrature prisms.<sup>59</sup>

All three remained hopeful about the prospects of some variant of their two-hologram techniques; shortly after Rogers’ move to New Zealand, Bragg wrote, “I am glad you had a chance to see Gabor’s latest development of the microscope. I went to see it recently. He seems to be getting on with it quite fast. The adjustments seemed a bit coarse to me for optical work, but he probably knows what he is about; at any rate, I hope we will soon see what it can do”.<sup>60</sup>

Nevertheless, these more complicated schemes involving the optical subtraction of one hologram reconstruction by another (also known as optical quadrature or nulling) attracted little enthusiasm. When Gabor presented one such experimentally delicate scheme at a conference on electron microscopy at the National Bureau of Standards in Washington, DC in 1951, he attracted only comments concerning its dubious feasibility.<sup>61</sup>

A new opportunity to promote diffraction microscopy developed in 1952, when Gabor began a collaboration with Max Born, then Professor of Mathematical Physics at the University of Edinburgh, and Emil Wolf, his son-in-law and a young PhD, on an English-language version of Born's respected German text *Optik*.<sup>62</sup> The book was to be an excellent opportunity to describe the principles of wavefront reconstruction, and Gabor eventually produced a chapter on his concept and limited experimental results.<sup>63</sup> Nevertheless, as Bragg had noted earlier, Gabor's exposition did not promote his ideas with clarity. Rogers was also a critic of what he saw as Gabor's excessively optimistic claims. Commenting on Gabor's draft chapter on wavefront reconstruction, Rogers wrote, "Fortunately, by now several people have taken the snags out of the original draft, and his claims are now much more modest and reasonable. I still feel, however, that they are not very helpful, though they are no longer unsound".<sup>64</sup> Born himself commented to Gabor, "I have read more of your MS. And I think that your considerations are most ingenious. But I can at the same time not conceal that they always seem to me a little weird, and prickle my physical sensitivities".<sup>65</sup>

## The Californian connection

Despite this unpromising reception, limited interest was developing elsewhere. First in Dundee and then in New Zealand, Rogers became a crucial conduit for information between Gabor at Imperial College and other researchers intrigued by wavefront reconstruction. Rogers struck up a correspondence with Paul Kirkpatrick of Stanford University from September 1950, after reading Kirkpatrick's proposal to apply Gabor's method to x-ray microscopy.<sup>66</sup> After Rogers sent a box of "assorted diffraction supplies" to get him started that December, Kirkpatrick replied:

I am having enlarged prints made from your microfilm, after reading it and realizing its importance to the education of my students and myself. We shall try some operations on the hologram you sent [...] I have interested two men here in diffraction microscopy and expect them to be much more active experimentally than I have been. One of these, Professor Albert V. Baez of Redlands University, Redlands, Calif, would benefit by correspondence with you [...] Baez is interested in the possibilities of x-ray diffraction microscopy but will begin with simple optical cases.<sup>67</sup>

Kirkpatrick confided that he had no intention of pursuing wavefront reconstruction directly, preferring instead to investigate a more readily achieved goal: creating an x-ray telescope by focusing x-rays from curved cylindrical mirrors. Rogers, perhaps relieved by the withdrawal of an experienced experimentalist and potential rival, continued to channel information between himself, Kirkpatrick and Gabor over the next year, and thereafter developed a close friendship with Baez. The other investigator at Stanford was Hussein M. A. El-Sum, Kirkpatrick's PhD student, with whom Rogers appears to have had no direct correspondence until 1952.

Rogers also maintained close contact with Gabor, coaching him on collaborating with the Americans in 1951:



If possible P. Kirkpatrick at Stanford would be a good point of call [...] Let me know in due course how our tour of the States is going, and how they are getting down to the technical work of making diffraction microscopy work. I bet it is a lot more slick and polished than yours truly on a shelf up in Dundee! I wonder, however, whether they are getting results any better.<sup>68</sup>

The experimental context was different in California, but not perceptibly better. During the early 1940s, Albert Baez had been teaching mathematics and physics in New York state, as part of the Army Specialized Training Program (ASTP), rising from instructor to tenured professor in the space of four years.<sup>69</sup> On the advice of a friend, he moved to Stanford University in 1944, again to teach on the ASTP program with Paul Kirkpatrick, who was acting head of the physics department while other academics were engaged in war work. When the war ended, Baez began a PhD with Kirkpatrick.<sup>70</sup>

Paul Kirkpatrick himself had come to Stanford University in 1931. Having engaged in x-ray research before the war, he had been considering an idea for building an x-ray microscope. The principle was quite unlike Bragg's concept of an x-ray microscope or Gabor's scheme for an improved electron microscope. Kirkpatrick envisaged that x-rays might be focused if reflected from surfaces at glancing incidence, which allows them to continue without absorption. In a university department impoverished by the war, Kirkpatrick and Baez pursued the project using scrap equipment. Baez was able to demonstrate the feasibility of constructing a focusing mirror from a slightly curved glass plate used at grazing incidence, which would produce a line image. Two such cylindrical mirrors in succession, used with their curvatures at right angles to each other, were able to focus radiation from an x-ray source to a point.

This scheme had no connection with Gabor's wavefront reconstruction concept. As they pursued their research on difficult microscopies, however, the Californian researchers learned of Gabor's concept and its possibilities. Baez imagined using a point source of x-rays to record an x-ray hologram. Kirkpatrick assigned another student, Hussein M. A. El-Sum, to explore this possibility as the task for his PhD dissertation. Baez took up a teaching post at University of Redlands, a small university in southern California with no track record in research.<sup>71</sup>

El-Sum studied and extended Gabor's microscopy by reconstructed wavefronts from late 1948, i.e. from the time Gabor began to present his work publicly. He completed his PhD on the subject in 1952, and Kirkpatrick published their first account of this research in an American journal the same year.<sup>72</sup>

Working in Paul Kirkpatrick's lab, El-Sum's ultimate aim was to apply Gabor's techniques to x-ray microscopy. He worked alongside members of the x-ray laboratory and Albert Baez, Kirkpatrick's former student, and corresponded with Gabor and Michael Haine by post. His dissertation, like the thinking of his contemporaries, situated wavefront reconstruction firmly in the context of microscopy. However, he set his sights more widely than did the British investigators. The first 124 pages considered the theoretical possibilities of the technique for other types of microscopy, and did so with mathematics that derived the principles in a more straightforward manner than Gabor had done.

The 75 page experimental section of El-Sum's thesis verified some characteristics of holograms that were predicted by, and yet counter-intuitive to, scientists of his generation:<sup>73</sup> that the hologram reconstructed two images, acting simultaneously as a converging and diverging lens; that the negative of a hologram behaved the same as the original positive hologram; and that, as Gabor had emphasized during 1948,

it is possible to reconstruct two objects in two different planes from the same diffraction picture [...]. This argument can be extended to any number of objects. This means that each plane in a thick object will be reconstructed independently.<sup>74</sup>

In other words, as Gabor had repeatedly stressed, a hologram should reconstruct an image having *depth*. But the three-dimensionality was not a matter of directly perceiving depth by two-eyed stereoscopy: El-Sum, like any contemporary microscopist, still envisaged viewing the reconstructed image either through an eyepiece or as a projection onto a surface. Thus wavefront reconstruction continued to be shaped and marginalized according to the conception of a particular scientific community, microscopists.

At Redlands University, Albert Baez followed the developments in Kirkpatrick's lab with interest. Baez was encouraged by his university administrators to introduce research by undergraduates. The idea appealed to the Research Corporation, which provided some financial support to get started. Kirkpatrick suggested to Baez that wavefront reconstruction using visible light – the kind of experiments that Gabor had performed at BTH and Imperial since 1948 – would be an ideal topic for undergraduate research, because of its low cost and ready availability of the necessary equipment. Baez himself hoped to piggyback on this optical research to extend the results to x-ray optics if and when a suitable source became available. He wrote to Rogers in early 1951,

I have come to consider Gabor's "holograms" as generalized Fresnel zone plates, and hence have an intuitive idea of what makes diffraction microscopy possible. I have made a hologram and lensless reconstruction [...] I am looking ahead to 2 wavelength microscopy – using x-rays to make the hologram and light to reconstruct. I am in the process of studying the matter to see what obstacles must be overcome first. I believe that I can learn a lot by practicing with visible light first, but hope to jump into x-rays as soon as I understand the situation a little better.<sup>75</sup>

By the 1950 teaching term, Baez and his students were recording holograms, and he was able to use an industrial grant to employ five undergraduates over the summer, organizing the research much like the graduate student teams supervised by Kirkpatrick at Stanford. Baez had thus begun the first teaching of wavefront reconstruction anywhere, and his activities comprised the largest research group in the subject through the 1950s.<sup>76</sup>

Just as the possibilities of Gabor's diffraction microscope had attracted a research grant for AEI from the DSIR a few years earlier, further research funding for Baez proved to be forthcoming. Baez visited V. E. Coslett and William C. Nixon at Cambridge University, who had developed an x-ray tube having an extremely small aperture and suitable as the needed 'point source' for x-ray wavefront reconstruction experiments. Baez was able to obtain a grant from the National Research Council in Washington, DC, to purchase one of the \$1000 Coslett-Nixon tubes and to bring Nixon to Redlands for a semester to set it up, subsequently attracting grants from the American Cancer Society and the Office of Naval Research. Baez and Bill Nixon found, however, that the x-ray source was not small enough to be deemed a 'point source'. When Nixon produced a projection radiograph of a silver grid, it showed only a single diffraction fringe. Such a hologram was too sparse to reconstruct anything like an image, and helped clarify their understanding of coherence. By comparison, the ongoing work of Dyson, Mulvey and Haine at AEI represented a superb success, yet one that was far from adequate to maintain their enthusiasm for long.<sup>77</sup>

## Wavefront reconstruction and communications theory

Thus, Dennis Gabor's conception of a diffraction microscope attracted a handful of prepared researchers in widely separated locales during the early 1950s. The last to develop an interest during that decade was a young German interested in the relationship between information and optics, a subject that Gabor himself had been studying from the mid 1940s.<sup>78</sup>

Adolf Lohmann (1926-) had picked up these interests towards the end of the Second World War.<sup>79</sup> A friend, Horst Wegener, had learned elements of signal processing theory while attending a 'radar school' for operators of newly developed Telefunken radar systems. When the war ended, and auxiliary combatants like Lohmann and Wegener were released from prisoner-of-war camps, they found the closest university, Hamburg, paralysed. The two decided to create their own informal academy, teaching math, philosophy and signal processing theory to three younger students. Both later studied for their graduate degrees in physics under Rudolf Fleischmann, who had been a professor at the R eichs-Universit at Strasburg, and returned to Hamburg when Strasburg reverted to French administration. There Fleischmann served as much as a construction manager to replace the bombed physics building as a scientist studying nuclear physics. As nuclear physics was not a permitted subject until 1953, Fleischmann turned to thin-film optics and Lohmann studied diffraction from gratings. He and Wegener gained their doctorates from the University of Hamburg in 1953, publishing a paper together that employed a signal-processing approach to optics.<sup>80</sup>

Out of this wartime technical knowledge and post-war study in optics came a distinct analytical viewpoint. During the mid 1950s Lohmann focused on the Abbe theory of the microscope, and its understanding of the image in terms of spatial frequencies.<sup>81</sup> According to Abbe, a microscope could be understood as a kind of optical filter. When light passes through a restricted opening, the image that it produces will be unavoidably altered. The aperture of the microscope optics limit its resolution. The degradation of the image could be represented as the removal of certain spatial frequencies, because the image itself can be decomposed into sinusoidal components of different frequencies. This 'Fourier decomposition' provides an elegant mathematical way of understanding image formation and alteration. Abbe's theory of microscopes could be generalized mathematically to describe any kind of optical process. This generalization could also be understood as the application of familiar concepts from the field of communications theory to physical optics.

Lohmann learned of Dennis Gabor's work by reading a conference report and later attending a seminar given by Gabor in G ottingen, but understood little.<sup>82</sup> Lohmann recalls Gabor's talk – "filled with integrals such that the concept was drowned" – as baffling and intimidating to the audience; no questions were asked. Lohmann overheard two of the G ottingen professors snidely referring to Gabor's theory as comparable to "onion radiation", a derided scientific claim with which Gabor had had an early association.<sup>83</sup>

Sensitive from his own experience to such out-of-hand rejection by arrogant academics, Lohmann remembers resolving to recuperate Gabor's work if possible. He worked on the draft of an article that analysed wavefront reconstruction in terms of signal theory.<sup>84</sup> Because Lohmann had done work on optical transform functions (OTFs), he had contact with Harold H. Hopkins at Imperial College who was well-known in the field. Lohmann obtained a short travel grant and visited Hopkins for a week in 1955, whose office was next to Gabor's. Owing to Lohmann's poor English, he spent more time with Gabor than with Hopkins. Lohmann had conceived his own method of avoiding the twin image problem, which Gabor praised as a simple

demonstration by comparison to his own complicated proposals. Gabor was enthused enough by Lohmann's work to send it to Haine and Dyson, presumably to indicate, if nothing else, that the research was not dead and buried.<sup>85</sup>

## 5. THE DECLINE OF DIFFRACTION MICROSCOPY

Nevertheless, by the time of Lohmann's visit in 1957, Gabor's concept had been abandoned by everyone – including, for all practical purposes, Gabor himself. For three years, 1949-1952, most of the work on diffraction microscopy had been carried out at AEI by Michael Haine, by Gabor with his student Goss, and independently by Gordon Rogers in Dundee and El-Sum and Baez in California. Gabor had contact with his AEI associates through their joint research grant and urged them on at every opportunity. Writing to Haine in 1949, for example, he had cajoled, “what a pity that it was not possible to produce some sort of electron-hologram for the Delft Conference, even a little smudge would have done [...] I am looking forward to having a little time to think about the outstanding problems of diffraction microscopy. It is my favourite baby, and I must not neglect it”.<sup>86</sup> His Delft paper consequently rehearsed his optical results to date, looking rather hopefully at the requirements for the coherence of the light source and perfection of the optical elements:

The objectives were full of local imperfections, and these produced a very uneven background on the photographic plate full of false detail. In order to get at the true detail it was necessary to subtract the background photographically [...] Even so, some “noise” persists in the background. It is comforting to think that we shall not have to contend with this difficulty in the electronic scheme. However bad an electron lens is, it is always perfectly polished, it has neither scratches, dust or cementing specks.

But, employing the opposite argument in his conclusion, Gabor forecast optimistically:

Thus, it can be hoped that the diffraction principle will allow us to shift the difficulties of phase contrast, like others, from electron optics to light optics, on to the shoulders of the optician, who will be well able to cope with them.<sup>87</sup>

During early 1950, the prognosis from AEI had looked promising, with Haine reporting, “since your visit we have been concentrating very hard on the holoscope [...] P.S. the first picture taken on the new system (i.e. object before objective) shows a nice 7-8 fringes over the whole of the picture with no distortion. Preliminary attempts at reconstruction of the negative show something (!)”.<sup>88</sup> These seven hard-won fringes from the electron microscope were about the best hologram achieved by the Aldermaston group. Gabor, immersed in teaching but at the peak of his enthusiasm, replied a month later, “This *is* a reconstruction, there is no doubt about it [...] I have no doubt that the same hologram with somewhat better photography would give an even better result”.<sup>89</sup> By summer, however, Haine reported that further work was making slow progress owing to vibration, mechanical drift and temperature variation of the electron microscope. Looking forward, Gabor predicted that to surpass the resolution of conventional electron microscopy by a significant factor (say a factor of ten) would require either that the electron beam be made some 100 times more monochromatic (thereby starving the image of energy) or by using an intermediary optical system of considerable complexity.<sup>90</sup>

Leaving the problems of electron microscope stability to the Aldermaston group, Gabor worked on optical schemes for improving the quality of reconstruction from his microscopic holograms. His hands were full with teaching, though, and a three-month trip to America; in the interim, his collaborators were losing their zeal. In late 1952 he wrote to Haine:

I was very distressed by my visit yesterday. I understand that for the time being you want to drop diffraction microscopy. My feeling is that this would mean, in all probability, dropping it for good. I do not know whether the decision corresponds or not with the lapse of the A.E.I.-D.S.I.R. contract, and anyway, I have no influence on that policy. All I can do, and want to do, is to impress on you that it would be unwise to terminate all work on it at the present stage, which would be interpreted by everybody outside as the admission of complete failure...<sup>91</sup>

Haine and his colleagues had not yet given up. In fact, they had convinced themselves that they could get by with rather few visible fringes from their electron beam, as Haine reported to Rogers:

The question of the visibility of the last fringe which you mention is one which worried us for some time but has now been cleared up. The question is better put in terms of communication theory. The random contrast (graininess) of the photographic plate can be considered as noise (it turns out to be almost completely random (white)). The question is, how much of the fringe system can be of such contrast that it is lost in the noise and yet still lead to reconstruction? The conclusion we arrived at (Gabor also) was that the whole fringe system could be below noise level. You will appreciate that this means 'lost' as far as any local measurement over a small area of the system is concerned or better, 'lost' as far as could be determined with incoherent illumination.<sup>92</sup>

Despite this theoretical easing of requirements, no practical improvement in results could be coaxed from the AEI apparatus. Correspondence between Gabor and Haine became sporadic and by 1954, Gabor was frustrated to the point of desperation, writing in confidence to Allibone at AEI:

Dear Edward,

I am writing this to you as to a friend. I feel that I have to do something about Diffraction Microscopy, because my scientific reputation is at stake, on the other hand I am in a rather worried state of mind, and there is the danger that I might damage myself by a too rash or harsh action. So if you think that the attached letter can do any good, please take official notice of it, and pass the copy on to Michael Haine, otherwise tear up both copies and let me know what you think of the situation...

The attached letter read:

I am considerably worried about the state and outlook of the work on Diffraction Microscopy. The impression has got abroad that it has led to disappointing results, and has been or is about to be abandoned. As I do not like being the bright boy who produces brilliant dud ideas, I should like to know a little more about the present position, and to give my help if possible.

Mr Dyson told me that he gave his opinion on the optical side of the Diffraction Microscopy method in a report, but I have not seen this. As regards the electronic side, I am almost equally in the dark. I have not yet seen any photographs taken with coherent electrons with half-tone objects; only black and white. I have made suggestions how to make use of the weak fringes in the shadow zone, but I do not know what has come out of these. Moreover I have not seen any photographs taken with coherent illumination for a long time; I think that the last I have seen were taken before the Washington Conference, in Nov 1951. I understand that the

last year was spent mainly improving the electron microscope on orthodox lines, but I have not yet seen any diffraction photographs taken with the improved instrument.

Are there any further difficulties, apart from those which Mr. Haine has published, and described *in extenso* in his last report on this subject, from which I had the impression that a resolution of 2.5 Å still appears obtainable?

You will understand that I am very anxious about these questions. I am in constant danger of overwork, yet if it has to be, I am willing to undertake the optical work myself, if this is the bottleneck, that is to say unless there are difficulties on the electronic side of which I am not sufficiently aware.<sup>93</sup>

Allibone, down with a cold, peevishly suggested a visit, because “Your letter reads as though you are almost ignorant of our present position, – which you should not be as a consultant on this work”.<sup>94</sup> The subsequent visit seemed to resolve nothing, however. Haine was not interested in further seemingly fruitless diversions from conventional transmission electron microscopy, which was improving incrementally.

Gabor kept trying to reinvigorate the cooperation at AEI. In an information-packed post-Christmas 1955 letter to Haine, Gabor enthused that his own work at Imperial was going well:

In the optical microscope we are now quite near to reconstruction [...] we have the two part-beams exactly parallel and capable of interference. We have also an almost-perfect quadrature prism, and most of the ghosts are eliminated. It took unearthly patience, but my chap Goss has got it!<sup>95</sup>

Eric Ash, working on the design of electron lenses for correcting the aberrations in electron microscopes as one of Gabor’s students from 1949 until 1952, suggested that experimental engineering was not Gabor’s forte:

He was one of only two or three people I have met that I would describe as a genius. He was warm, but he was an awful supervisor. He had difficulties, communicating on the same wavelength as ordinary mortals. Secondly, he was clearly a physicist, although he had been brought up as an engineer. He had the illusion that he was an engineer, which is the inverse of what one expects [...] He was absolutely hopeless on experiments [...] For many years I enjoyed the reputation of being the only chap who got a Ph.D. out of him.<sup>96</sup>

#### Figure 5 Design of Gabor’s two-hologram interference microscope (1951)

Gabor continued work at Imperial College with assistant W. P. Goss between 1951 and 1956 on the more complex optical reconstruction apparatus, but commercial hopes for the quadrature method could not be sustained. Although he had filed British and American patents on the method in 1951, his experiments with Goss eventually convinced him that the method was impracticable. Gabor noted a decade later that they performed few experiments with the apparatus because, by the time they had learned how to make good quadrature prisms, Goss’s scholarship had nearly run out. Gabor confided to Gordon Rogers, “There is just no business in this sort of thing, I am sorry to say. I wish I had not wasted so much time on patent applications myself!”<sup>97</sup>

The other researchers were following a similar trajectory of pessimism and dismissal. Gordon Rogers, who had been the most enthusiastic and consistent investigator of diffraction microscopy in Britain, also had found his faith in Gabor’s concept waning during the early

1950s. Like Gabor, he had had suspicions as early as 1950 that the technique was fundamentally limited, and that a single hologram could not reconstruct an unambiguous complete image, suggesting that the limitation probably followed from the second law of thermodynamics.<sup>98</sup> Their separate attempts to find a theoretical and practical solution through pairs of holograms were inconclusive by 1952. While continuing to explore the technique himself sporadically over five years, Rogers had given up on optical applications. He confided his pessimism to Gabor in 1954, focusing on the AEI experimental problems, the lack of interest of other researchers, and the strong constraints on the kind of microscopic object that could be examined by a diffraction microscope.<sup>99</sup> At that time Gabor remained optimistic, writing,

You write that 'Diffraction Microscopy seems quite dead as a method for aiding the electron microscope'. If it is temporarily dead, it is so by neglect and for no other reason. Dyson just could not take any interest in it, and Haine was discouraged by his attitude. I wish they had taken you at that time! Now I have undertaken to do the reconstructions myself. It may have been a lightheaded promise, because I am up to the neck in work, but I cannot leave this job in the state it is.<sup>100</sup>

Yet everyone else had had enough. Discussing the problem of the seemingly unavoidable twin image and the serious degradation caused by dust and imperfections in the optics, Rogers reiterated to Albert Baez in 1956, "As far I am concerned, I am quite happy to let Diffraction Microscopy die a natural death. I see relatively little future for it, and am looking forward to doing something else".<sup>101</sup> His final attempt to make something of the technique during 1955-57 was a proposal for analyzing ionospheric measurements according to the ideas of wavefront reconstruction.<sup>102</sup> Kirkpatrick and El-Sum published more work in the mid 1950s,<sup>103</sup> but Baez ceased his own research and teaching on what he called 'Gaboroscopy' when he left Redlands University in 1958 to take up a post at MIT.<sup>104</sup>

In the same way, the AEI electron interference work, intended to generate electron wave holograms to complement Gabor's optical reconstruction apparatus, was effectively dead at AEI. From 1954, the bulk of Gabor's consultancy work for AEI had focused on the theory of nuclear fusion, while diffraction microscopy was shelved quietly by both sides. By 1958, Allibone publicly narrated the work in historical terms, dismissing it as one of many white elephants that the company had produced:

We spent a great amount of time investigating this idea, solving very many different problems in sequence, such as keeping the specimen free from contamination for half an hour and free from vibration to the order of 1 Å and holding the voltage constant to 0.1 V in 100 000 V for half an hour, but the best holograms we could produce failed to give us a reconstructed image as good as the image we could then achieve by direct microscopy and we were obliged to drop the work. To that extent, therefore, it can be regarded as having been unsuccessful, but out of it we have learned so much about microscopy that the E.M. 6 has been produced capable of a resolution of 5 Å.<sup>105</sup>

Acrimony flared only once more, following a 1961 article by Gabor in *New Scientist*. Allibone wrote Gabor to complain that he had misrepresented the failure of wavefront reconstruction:

It said that "the results were spectacular, but unfortunately trivial disturbances, such as vibrations and stray magnetic fields, have proved so far an insuperable drawback".

Surely this is absolutely wrong; if I have remembered correctly, the failure of the whole principle of electron microscopy by reconstructed wavefronts was the confusion caused by the second image... In other words, if we overcame those trivial disturbances we could still not make a success of electron microscopy by reconstructive wavefronts. I do think it is important that this misconception be adjusted.<sup>106</sup>

Gabor, in a detailed letter to his friend five days later, replied that he was in complete disagreement with Allibone, Haine and Dyson at AEI. Any remaining opportunities for collaborative research dissolved when the Aldermaston research station was closed in 1963, transferring its work to Gabor's old laboratory at BTH in Rugby and to Metrovick in Manchester. Tellingly, even Gabor left his optical reconstruction work with Goss unpublished until 1966.<sup>107</sup>

Thus wavefront reconstruction had had a shaky ten-year run and a decisive termination. The new subject appeared to outsiders to have been evaluated fairly, but found wanting on intellectual grounds. To most microscopists, it seemed arcane, complex and unpromising, in part because of Gabor's expository style. Yet Gabor had worked hard to develop interest in his concept, and used it effectively to advance his career. He had gained crucial support during the early months from Sir Lawrence Bragg, Gordon Rogers, T. E. Allibone and later Max Born. Gabor's colleagues at AEI and his student W. P. Goss had struggled to obtain experimental results, and the practice and theory had been extended further by Hussein El-Sum, Albert Baez and Adolf Lohmann. Collectively, these researchers had competently defined the nature and the problems of wavefront reconstruction.

The most important conclusions drawn by this band of investigators concerned the drawbacks of their new subject in clear terms: most saw it as fatally flawed by the twin image problem, in which the fuzzy second image seemed doomed to overlap the desired image, rendering the technique unsatisfactory for any practical use. Yet at least three other technical reasons were to circulate for the demise of wavefront reconstruction: limitations of the electron source (Allibone and Gabor); complexity and inadequacy of optical solutions for removing the conjugate image (Haine, Rogers, Bragg, Lohmann, Gabor and Goss); and, later, the inadequate coherence of the available light sources (Gabor). Perhaps most limiting of all was their consensus that wavefront reconstruction was a form of *microscopy*: an imaging technique for microscopic samples. There are at least four explanations for this perceptual pigeon-holing: first, Gabor's conception had begun with the problems he perceived for electron microscopy; second, his 'holoscope' had formal similarities to preceding instrument concepts (the Abbe theory of spatial frequencies and the Bragg x-ray microscope); third, he had promoted wavefront reconstruction specifically to microscopists via demonstrations and papers; and fourth, those who took an interest in Gabor's work were themselves seeking to improve microscopy. This constraining view of the subject thus followed from its disciplinary origins and perceptions of its similarity to earlier research. There was a second constraint on how they conceived the boundaries of their subject, namely their implicit assumptions. As the writings of Gabor and El-Sum indicate, both were well aware that wavefront reconstruction would record three dimensions of a sample, and yet neither ever mused about stereoscopic imaging. This was natural, considering their labelling of the technique as a microscopy. Microscopes had associated traits that may have seemed inescapable: they were traditionally optical devices centred on a single axis, and used an eyepiece for viewing. Such physical limitations could well have hindered ideas about more creative geometries. In practice, stereoscopy was not even conceivable for them.

In their various ways, these evaluations were constrained by their investigators' histories, backgrounds and working contexts. These influences could be termed '*contextual*



*screening*: the researchers' disciplines and intellectual starting points created perceptual barriers restricting their conception of the new subject. The power of contextual screening is suggested by the fact that Dennis Gabor, a highly creative inventor with direct recent experience in both stereoscopic imaging and information theory, failed to make connections between these subjects and his work on wavefront reconstruction. From the standpoint of Gabor and the others, the intellectual environment of wavefront reconstruction had been thoroughly explored; they could scarcely recognize barriers imposed by their working cultures, or the intellectual territory that might offer other routes.

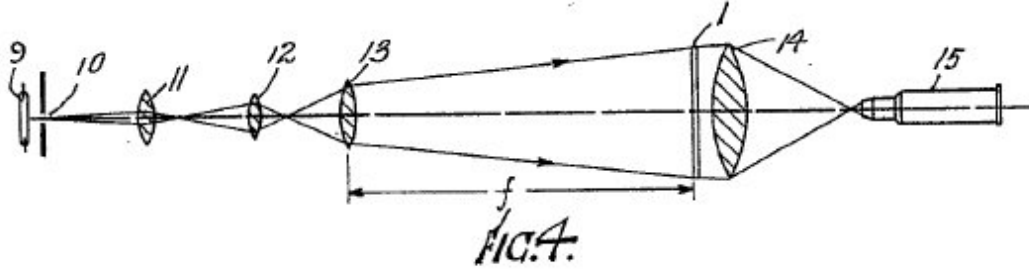
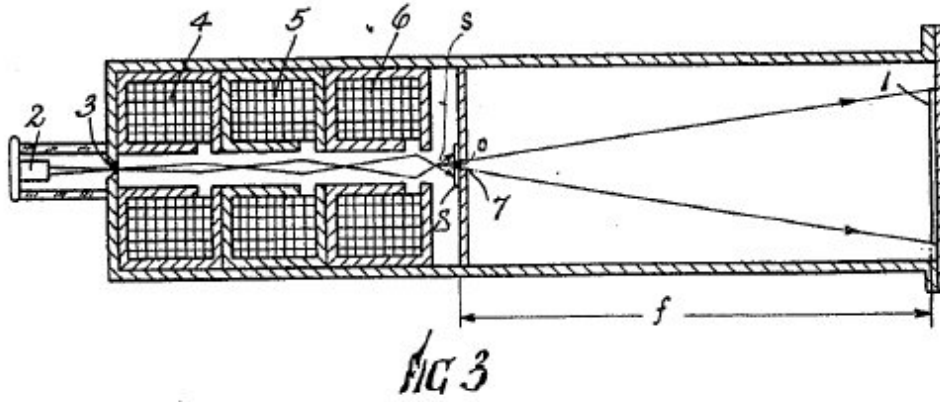
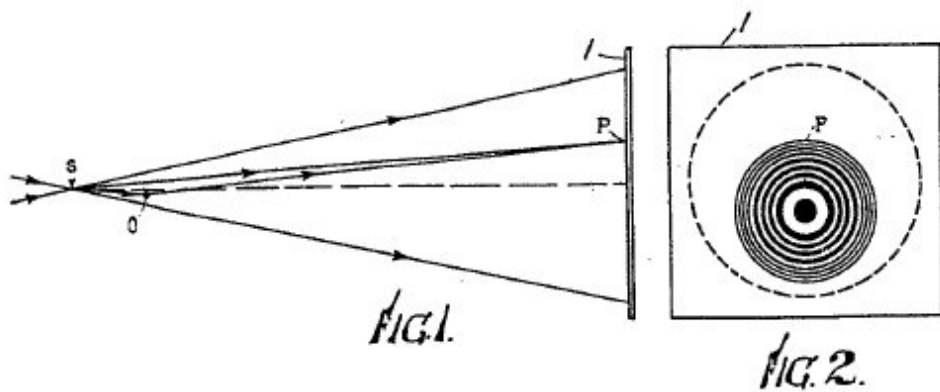

**Figure 1:** Gabor patent illustrations, Dec 1947. **FIG.1:** Illustration of source point S, rays diffracted at object point O, and resulting interference with undeviated rays at point P. The hologram is the pattern of such interference points at surface  $l$ . **FIG.2:** Appearance of interference pattern produced by the diverging beam and 'punctiform object' (i.e. opaque spot O). **FIG.3:** Diagram of the electron-beam portion (i.e. first half) of the holoscope, which employs three electromagnetic lenses to produce a divergent beam diffracted by the object at O. **FIG.4:** Diagram of the optical reconstruction portion (i.e. second half) of the holoscope, which Gabor dubbed a 'synthetizer' (sic). The hologram  $l$  yields a reconstructed image visible in microscope eyepiece 15.

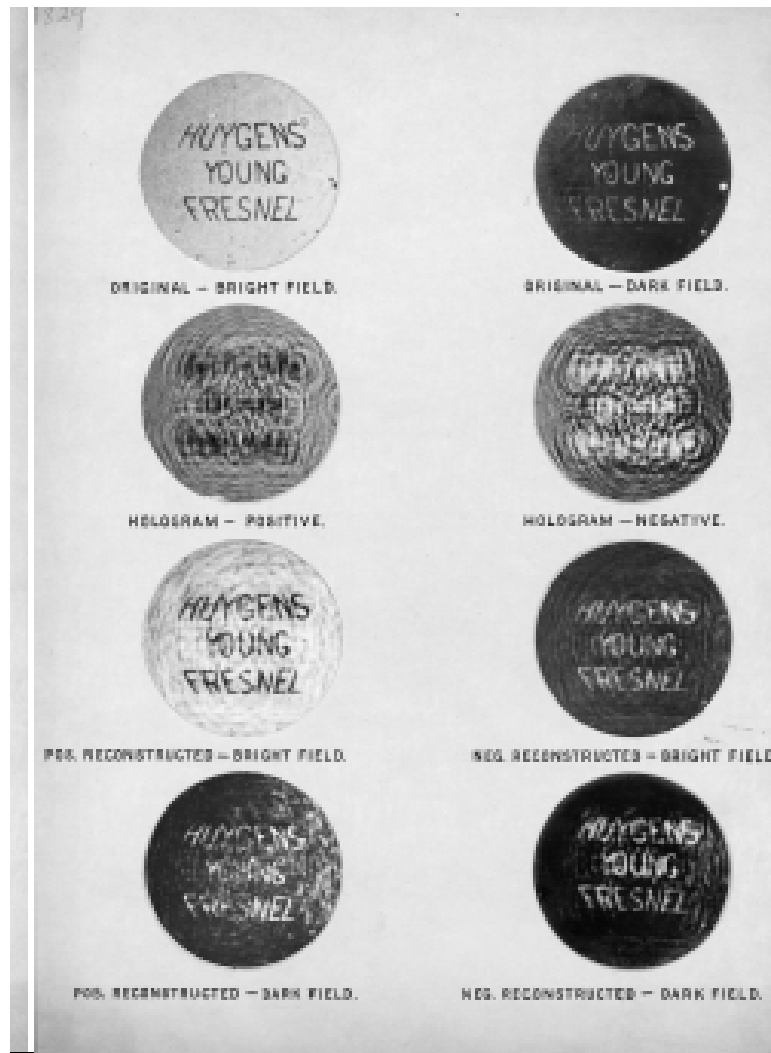

**Figure 2:** 1948 Gabor poster



**Figure 3:** Gabor in middle age

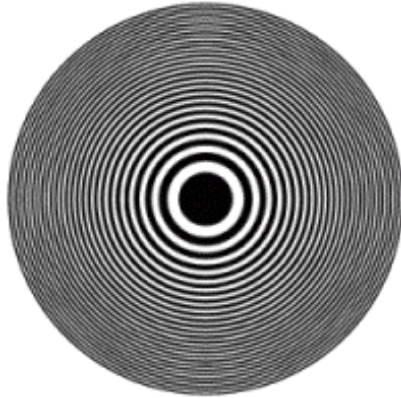

**Figure 4:** Zone plate

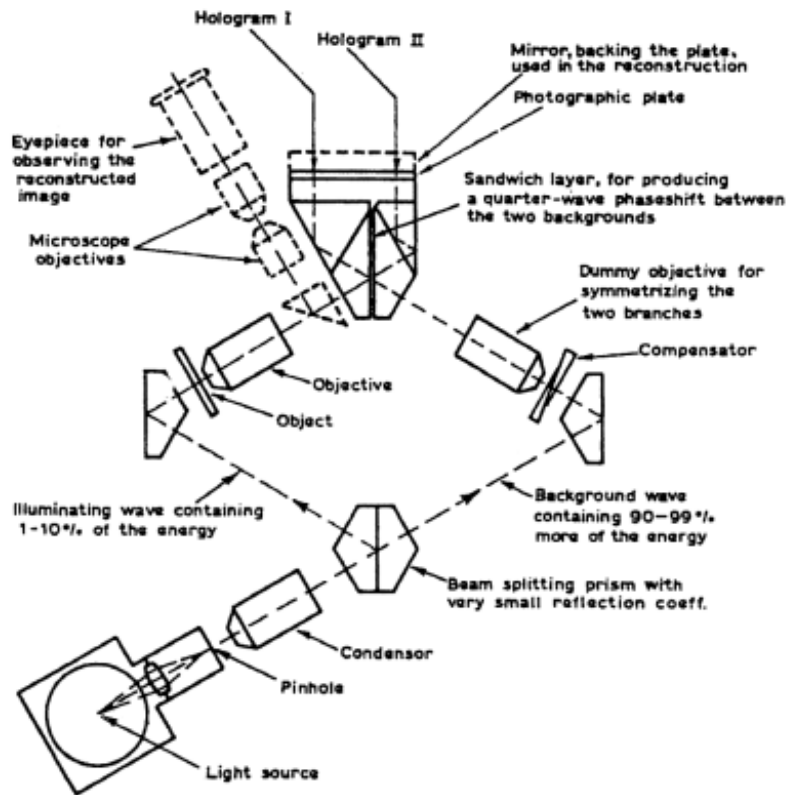

**Figure 5:** Gabor's two-hologram interference microscope of 1951

<sup>1</sup> "New Microscope Lims Molecule: Britons impressed by paper combining optical principle with electron method," *Times*, 15 Sep 1948, . Gabor had not, of course, come close to delineating or visually depicting a molecule; to truly limn a molecule long remained the holy grail of microscopists.

<sup>2</sup> On the sources of this rehabilitation, see Sean F. Johnston, "Telling tales: George Stroke and the historiography of holography," *History and Technology*, 20 (2004), 29-51. Regarding the explosion of three-dimensional holography, see Sean F. Johnston, "Shifting perspectives: holography and the emergence of technical communities," *Technology & Culture*, 46 (2005), 77-103 and Sean F. Johnston, "Absorbing new technologies: holography as an analog of photography," *Physics in Perspective*, 7 (2005), (in press).

<sup>3</sup> T. E. Allibone, "Dennis Gabor: A biographical memorial lecture," *Holosphere*, 10 (1981), 1, 4-6, and Dennis Gabor, typewritten CV to Appointment Committee for Chair in Electron Physics, 19 Feb 1958.

<sup>4</sup> Dennis Gabor, letter to T. Raison, 15 Jul 1961. Among the notable Hungarians of that generation were the physicist/physiologist Georg von Békésy (1899-1972), aerodynamicist Theodore von Kármán (1881-1963), author Arthur Koestler (1905-1983), the computer pioneer John von Neumann (1903-1957), and nuclear physicists Leo Szilard (1898-1964), Edward Teller

---

(1908-2003) and Eugene Wigner (1902-1995). Gábor (1900-1979), was also part of that restless wave. Indeed, Gábor, von Kármán, von Neumann, Szilard, Teller, and Wigner were born in the same quarter of Budapest [Lee Edson, "A Gabor named Dennis seeks Utopia," *Think*, January-February 1970: 23-7, Dennis Gabor, letter to T. Raison, 15 Jul 1961].

<sup>5</sup> BTH survived the depression with the aid of income from its electric lamp products, but also contributed to the development of jet engines and radar equipment. After the war, continued rivalry with Metrovick weakened the AEI group of companies. [Robert Jones and Oliver Marriott, *Anatomy of a Merger: a History of G.E.C, A.E.I. and English Electric* (London, 1970)].

<sup>6</sup> T. E. Allibone, "Dennis Gabor 1900-1979," Memorial service address, Holy Trinity Church, 15 Mar 1979.

<sup>7</sup> Dennis Gabor, letter to T. Raison, 15 Jul 1961. Oscar Deutsch (1893-1941), creator of the Odeon cinema chain from 1931, had produced a chain of 248 cinemas within a decade.

<sup>8</sup> Ernst Ruska (1908-1988), who also attended the Technische Hochschule Berlin-Charlottenburg, investigated the electromagnetic electron lens in 1931, and used several in series to produce the first electron microscope two years later. Siemens-Reiniger-Werke AG, which Ruska joined in 1937, brought out the first commercial electron microscope in 1939. Max Knoll first described the concept of the *scanning* electron microscope in 1935. By that time, independent research groups were pursuing electron microscope development in Britain, America, Canada, France, Sweden and Belgium.

<sup>9</sup> For an insightful analysis of the early standardisation and application of electron microscopes, see Nicolas Rasmussen, *Picture Control: the Electron Microscope and the Transformation of Biology in America, 1940-1960* (Stanford, Calif., 1997).

<sup>10</sup> Dennis Gabor, *The Electron Microscope: Its Development, Present Performance, and Future Possibilities* (London, 1948).

<sup>11</sup> The accounts of the genesis of his ideas were nearly all recorded many years after the event. See, for example, Dennis Gabor, letter to T. Raison, 15 Jul 1961, ---, letters to I. Williams, , ---, "Holography, 1948-1971," in: Nobel Prize Committee (ed.), *Les Prix Nobel En 1971* (Stockholm, 1971), pp 169-201, ---, "Holography, past, present and future," *Proceedings of the SPIE The International Society for Optical Engineering*, 25 (1971), 129-34.

<sup>12</sup> Dennis Gabor, letters to N. Calder, . This retelling of the origins evokes Albert Einstein's descriptions of how he developed the theory of special relativity from schoolboy speculations of travelling alongside a beam of light. Huygen's Principle states that every point on a wave acts as a source of spherical waves, and that the wave pattern at a later time is merely the sum of these individual wavelets.

<sup>13</sup> Dennis Gabor, letters to T. E. Allibone, 1932-1954, IC.

<sup>14</sup> Strictly speaking, the intensity will fall to zero only if the two waves have equal amplitudes; if not, the intensity fluctuations, or contrast, will be smaller. Concepts of optical coherence were further explored during the early 1960s, after the advent of the laser. See, for example, R. J. Glauber, "Coherent and incoherent states of the radiation field," *Physical Review*, 131 (1963), 2766, M. J. Beran and G. B. Parrent Jr., *Theory of Partial Coherence* (Eaglewood Cliffs, NJ, 1964) and L. Mandel and E. Wolf, "Coherence properties of optical fields," *Reviews of Modern Physics*, 37 (1965), 231.

---

<sup>15</sup> Dennis Gabor, "Holography, 1948-1971," in: Nobel Prize Committee (ed.), *Les Prix Nobel En 1971* (Stockholm, 1971), pp 169-201, p.16.

<sup>16</sup> Dennis Gabor, letter to P. Goldmark, 3 June 1967, IC. No notebooks or equipment survive from this work, despite attempts to locate them for the Smithsonian museum during 1965-66. [Ivor Williams, letter to D. Gabor, 20 Dec 1966]. The Gabor archives hold copies of the enlarged photographic prints made of the holograms and reconstructions [IC GABOR D/39].

<sup>17</sup> Sir William Lawrence Bragg FRS (1890-1971) had worked with his father William Henry Bragg on x-ray analysis of crystal structure, winning them the Nobel prize in 1915 (the youngest ever laureate). For the following four years, the younger Bragg was Technical Advisor in sound ranging for the British army, subsequently taking up a Professorship in Physics at the University of Manchester for the following eighteen years, Directorship of the National Physical Laboratory 1937-39, and then the Cavendish chair in Physics until 1953.

<sup>18</sup> W. L. Bragg, "A new type of X-ray microscope," *Nature*, 143 (1939), 678.

<sup>19</sup> Dennis Gabor, Letter to S. L. Bragg, 19 Jan 1948. Physicist (Vernon) Ellis Coslett FRS, president of the Royal Microscopical Society, founded the Electron Microscopy section of the Cavendish Laboratory, Cambridge.

<sup>20</sup> J. B. Le Poole, letter to D. Gabor, 21 Jan 1948 and Dennis Gabor, letter to J. B. Le Poole, 5 Feb 1948. The patent was British patent 685,286 "Improvements in and relating to microscopy", filed on 17 Dec 1947 and published 31 Dec 1952. Gabor never sought a patent for 'wavefront reconstruction' itself.

<sup>21</sup> Dennis Gabor, Letter to J. B. Le Poole, 5 Feb 1948, IC.

<sup>22</sup> His contemporaries did not favour the term. Gordon Rogers observed three years later, "I shed no tears over the loss of the term 'hologram'; it was too like the word 'holograph', which has been in good standing with quite another meaning in Scots Law for some centuries. But it is not so easy to find a substitute" [Gordon L. Rogers, letter to A. Boivin, 1951, SM]. Rogers pondered the merits of the terms "physical shadow", "diffraction image" or "Fresnel diffraction pattern" with dissatisfaction.

<sup>23</sup> Dennis Gabor, Pat. No. 685,286 "Improvements in and relating to Microscopy" (1947), assigned to British Thomson-Houston, p. 4.

<sup>24</sup> Between 1940 and 1944, Gabor had patented a series of inventions for the filming and projection of stereoscopic pictures and movies. See P.G. Tanner and T. E. Allibone, "The patent literature of Nobel laureate Dennis Gabor (1900-1979)," *Notes and Records of the Royal Society of London*, 51 (1997), 105-20, for a list and brief discussion.

<sup>25</sup> Dennis Gabor, Pat. No. 685,286 "Improvements in and relating to Microscopy" (1947), assigned to British Thomson-Houston, p. 2.

<sup>26</sup> Dennis Gabor, file to 1948.

<sup>27</sup> Dennis Gabor, IC GABOR EL/1 to S. L. Bragg, March - July, 1948.

<sup>28</sup> Dennis Gabor, letter to S. L. Bragg, 7 July 1948.

<sup>29</sup> Dennis Gabor, "A new microscopic principle," *Nature*, 161 (1948), 777-8, p. 778.

<sup>30</sup> Dennis Gabor, letter to S. L. Bragg, 7 July 1948.

---

<sup>31</sup> At this time Gabor knew, and corresponded with, Max Born, Rudolph Peierls, P.A.M. Dirac, Louis de Broglie and Sir Charles Darwin (grandson of the evolutionist); even considering the unusually rich post-war flux of émigré scientists, he was a well connected industrial scientist indeed.

<sup>32</sup> Dennis Gabor, letters to R. Peierls, 15 June 1948, IC.

<sup>33</sup> Dennis Gabor, IC GABOR EL/1 to S. L. Bragg, March - July, 1948, IC.

<sup>34</sup> Sir Lawrence Bragg, letter to D. Gabor, 5 July 1948, IC.

<sup>35</sup> Sir Lawrence Bragg, letter to D. Gabor, 27 July 1948, IC.

<sup>36</sup> Dennis Gabor, "Microscopy by reconstructed wavefronts," *Proceedings of the Royal Society of London, Series A*, 197 (1949), 454-87, p 456.

<sup>37</sup> Gabor later recalled that for his informal talk and demonstration at the Brighton meeting, BTH had "generously paid my 3d class fare Rugby-Brighton, but the hotel for only one night, because employees were not supposed to attend meetings without giving lectures" [Dennis Gabor, letters to N. Calder, ].

<sup>38</sup> Dennis Gabor, "Optical synthesizer for electron microscope," Report, British Thomson-Houston, Sep 1948.

<sup>39</sup> The earliest of them, the gas discharge lamp invention that he brought to BTH in 1934, had not been pursued after 1940: it could not compete with the new fluorescent lamps then being introduced, and GEC plc, the main potential customer, eventually decided not to take up an option. An option was, however, taken up by Philips and General Electric in 1939 and 1940, respectively. See Dennis Gabor, typewritten CV to Appointment Committee for Chair in Electron Physics, 19 Feb 1958, IC.

<sup>40</sup> Dennis Gabor, letter to T. E. Allibone, 4 May 1947.

<sup>41</sup> Dennis Gabor, letter to I. C. Prof. Willis Jackson, 28 Sep 1948.

<sup>42</sup> Dennis Gabor, letter to C. R. Burch, 11 Sep 1950; W. L. Bragg, "Microscopy by reconstructed wavefronts," *Nature*, 166 (1950), 399-400; M. E. Haine and J. Dyson, "A modification to Gabor's diffraction microscope," *Nature*, 166 (1950), 315-6.

<sup>43</sup> Gordon Leonard Rogers had a peripatetic early career, with lectureships at the Carnegie Laboratory of Physics at University of Dundee (1946-); Victoria University College in Wellington, New Zealand (1952-55); in 1957 seeking jobs at Aldermaston, Nottingham and Sheffield; and finally a Principal Lectureship in Wave Optics at the College of Advanced Technology, Birmingham, and subsequently Professorship of Physical Optics at the rebranded University of Aston in Birmingham. The Rogers papers are archived at the Science Museum library, Imperial College.

<sup>44</sup> Gordon L. Rogers, files, 1942-44, IC.

<sup>45</sup> Gordon L. Rogers, "Comments by Dr. G. L. Rogers on Dr D. Gabor's Report B. T. H. No. L. 3696," report, Sci Mus ROGRS 6, 18 March 1948.

<sup>46</sup> Gordon L. Rogers, letter to D. Gabor, 12 Nov 1949, SM.

<sup>47</sup> Gordon L. Rogers, "Experiments in diffraction microscopy," *Proceedings of the Royal Society (Edinburgh)*, A63 (1952), 193.



---

<sup>48</sup> For example, an optical alternative to drawing and laboriously inking in such patterns was to photograph interference between monochromatic light reflections from a flat surface and a spherical lens, an arrangement noted by Isaac Newton in the seventeenth century and known as ‘Newton’s rings’ [R. W. Wood, *Physical Optics* (New York, 1929), pp 36-41]. The Fresnel zone plate had been first described and coined by Lord Rayleigh in 1871.

<sup>49</sup> Sir Lawrence Bragg, letter to D. Gabor, 5 July 1948.

<sup>50</sup> Gordon L. Rogers, "Gabor diffraction microscopy: the hologram as a generalized zone-plate," *Nature*, 166 (1950), 237-8.

<sup>51</sup> Gordon L. Rogers, lab notebook, 21 Jan 1949 -1950, Sci Mus ROGRS 2/10 and 2/11. The lens formula relates the focal length of a lens to its distance from the object and corresponding focused image.

<sup>52</sup> Gordon L. Rogers, "Gabor diffraction microscopy: the hologram as a generalized zone-plate," *Nature*, 166 (1950), 237-8.

<sup>53</sup> Dennis Gabor, letter to G. L. Rogers, 18 Aug 1950.

<sup>54</sup> Dennis Gabor, letter to G. L. Rogers, 6 Nov 1950; Dennis Gabor, "A New Interference Microscope," mimeographed report, Imperial College, 4 Dec 1950; Dennis Gabor, letter to L. J. Davis, 18 May 1951.

<sup>55</sup> Gabor’s ideas changed about the relationship between the conjugate image and three-dimensionality: for example, he wrote, “though, as is well known, a single hologram does not contain the full information on a general object, it entirely describes a *plane object*, hence it should be possible to obtain a *full* reconstruction, eliminating the “conjugate object”, if we use the correct procedure” [Dennis Gabor, report to unspecified recipient, 7 Jul 1951].

<sup>56</sup> E.g. Dennis Gabor, "A new interference microscope," mimeographed report, Imperial College, 4 Dec 1950; Dennis Gabor, ""Diffraction microscopy. Full reconstruction by interpolation", report, Imperial College, 7 Jul 1951; Dennis Gabor, "Microscopy by reconstructed wavefronts: II," *Proceedings of the Physical Society (London)*, B64 (1951), 449-69. Goss (born in 1927) held an MSc when he was working with Gabor.

<sup>57</sup> Dennis Gabor, letter to M. E. Haine, early 1951. Thus, an opportunity for close collaboration between optical and electron microscopy researchers never developed. Rogers took up a new university post in New Zealand in 1952.

<sup>58</sup> W. L. Bragg and Gordon L. Rogers, "Elimination of the unwanted image in diffraction microscopy," *Nature*, 167 (1951), 190-3. see also Gordon L. Rogers, "Two hologram methods in diffraction microscopy," *Journal of the Optical Society of America*, 56 (1956), 849-58.

<sup>59</sup> Gordon L. Rogers, letter to D. Gabor, 1 Nov 1951.

<sup>60</sup> Sir Lawrence Bragg, letter to G. L. Rogers, 25 Mar 1952.

<sup>61</sup> Dennis Gabor, "Progress in microscopy by reconstructed wavefronts," presented at *Conference on Electron Microscopy*, Washington, 1951.

<sup>62</sup> The relationship between Born and Gabor was a close, respectful and honest one, given the very different backgrounds and status of the two men. Gabor commiserated at their over-work, suggesting that “both you and I have chosen the wrong country to settle in after Germany” and

---

advising that Born seek a post in America, or at least consulting work, as Gabor himself had done that year [Dennis Gabor, letter to M. Born, 5 Dec 1951].

<sup>63</sup> The first edition [Max Born and Emil Wolf, *Principles of Optics: Electromagnetic Theory of Propagation, Interference and Diffraction of Light* (London; New York, 1959)], the most rigorous and canonical optics text of its generation, appeared in 1959 with Born and Wolf as principal authors. Following the irritation that both felt on the dissolution of the partnership of their publisher, Gabor decided to withdraw as co-author, providing instead chapters on diffraction and interference microscopy, and on electron optics for the book. Born returned to Germany on his retirement in 1953, and a year later was awarded the Nobel Prize in Physics. The only other book of the period to discuss wavefront reconstruction was Richard S. Longhurst, *Geometrical and Physical Optics* (London, 1957).

<sup>64</sup> Gordon L. Rogers, letter to G. D. Preston, 2 Sep 1952.

<sup>65</sup> Max Born, letter to D. Gabor, 21 Feb 1951.

<sup>66</sup> Paul Kirkpatrick, "An approach to X-ray microscopy," *Nature*, 166 (1950), 251; Gordon L. Rogers, letter to P. Kirkpatrick, 13 Sep 1950.

<sup>67</sup> Paul Kirkpatrick, letter to G. L. Rogers, 3 Dec 1950.

<sup>68</sup> Gordon L. Rogers, letter to D. Gabor, 1 Nov 1951.

<sup>69</sup> Albert V. Baez, "Anecdotes about the early days of x-ray optics," *Journal of X-Ray Science and Technology*, 7 (1997), 90-7.

<sup>70</sup> Paul Kirkpatrick (b1894), completed a BS in physics (1916) from Occidental College and a PhD in 1923, taught physics and English in China 1916-18, was professor of Physics at the University of Hawaii 1923-1931, and was thereafter at Stanford until 1959.

<sup>71</sup> Hussein Mohammed Amin El-Sum (c1922-c1971) was born in Cairo, Egypt and obtained his BS degree in Physics from Cal Tech and his PhD in physics from Stanford in 1952. During the 1960s and early 1970s he was active in acoustical holography through his firm, El-Sum Consultants.

<sup>72</sup> H. M. A. El-Sum, *Reconstructed Wave-Front Microscopy*, PhD thesis, Physics, Stanford University (1952); Hussein M. A. El-Sum and Paul Kirkpatrick, "Microscopy by reconstructed wave-fronts," *Physical Review*, 85 (1952), 763.

<sup>73</sup> Gabor and El-Sum had founded their theoretical understanding of wavefront reconstruction on the Abbe theory of the microscope (1873) and Huygen's principle (1678), which explain image formation from optical interference of light waves. Most microscopists and even physicists were much more familiar with classical 'geometrical' optics, in which light is considered in the approximation of geometrical imaging. The Abbe theory, however, had at its heart ideas linking imaging with frequency analysis and information theory, connections that Gabor and others were to elaborate from the 1950s; see Adolf Lohmann, below.

<sup>74</sup> H. M. A. El-Sum, *Reconstructed Wave-Front Microscopy*, PhD thesis, Physics, Stanford University (1952), p 57.

<sup>75</sup> Albert V. Baez, letter to G. L. Rogers, 16 Jan 1951.

---

<sup>76</sup> Significant publications during this period were Albert V. Baez, *Journal of the Optical Society of America*, 42 (1952), 756, ---, "Resolving power in diffraction microscopy," *Nature*, 169 (1952), 963-4.

<sup>77</sup> M. E. Haine and T. Mulvey, *Journal of the Optical Society of America*, 42 (1952), 756.

<sup>78</sup> Dennis Gabor, "Theory of communication," *Proceedings of the IEEE*, 93 (1946), 429-57.

<sup>79</sup> Adolf W. Lohmann, fax to SFJ, 20 May 2003, ---, fax to SFJ, 13 May 2003; Adolf W. Lohmann, patent declaration to patent attorneys, c1986.

<sup>80</sup> Adolf W. Lohmann and Horst Wegener, "Theory of optical image formation using a plane waves expansion," *Zeitschrift für Physik*, 143 (1955), 431-4.

<sup>81</sup> Adolf W. Lohmann, "A new duality principle in optics, applied to interference microscopy, phase contrast etc.," *Optik*, 11 (1954), 478-88, ---, "The Abbe experiments as methods for measuring the absolute light phase," *Zeitschrift für Physik*, 143 (1956), 533-7. This perspective on optics, arriving second-hand from radar analysis, was common to two other investigators, Emmett Leith and Yuri Denisyuk, discussed in the following chapters.

<sup>82</sup> Adolf W. Lohmann, patent declaration to patent attorneys, c1986.

<sup>83</sup> In 1923, Alexander G. Gurwitsch (or Gurvich), on experiments with onion roots, had hypothesised that they emitted radiation, probably at ultraviolet wavelengths, that promotes cell division in other nearby roots [see A. G. Gurwitsch and L. D. Gurwitsch, "Twenty years of mitogenetic radiation," *Uspechi Biol. Nauk. V.*, 16 (1943), 305-34]. Tiberios Reiter, a medical acquaintance of Gabor, had read such reports and inferred a more general connection with health. Gabor consequently developed a lamp that he expected would reproduce these reputed 'mitogenetic rays' and hence this beneficial effect. An arc lamp, filtered by a coloured solution, yielded ultraviolet radiation described as useful for agriculture or for the "destruction of pernicious tumours". Gabor made it the subject of his first patent [German patent 578,709, "Einrichtung zur Behandlung von lebenden Zellen mittels Lichtstrahlen", filed on 7 Aug 1927; Gabor also had it filed in France, Britain, Switzerland and America over the following two years, e.g. as US #1,856,969: "Treating living cells with light rays"].

<sup>84</sup> Adolf W. Lohmann, "Optical single side band transmission applied to the Gabor microscope," *Optica Acta*, 3 (1956), 97-9.

<sup>85</sup> Dennis Gabor, letter to A. Lohmann, 5 May 1957, ---, letter to A. Lohmann, 2 Jan 1957.

<sup>86</sup> Dennis Gabor, letter to M. E. Haine, 18 June 1949.

<sup>87</sup> Dennis Gabor, "Problems and prospects of electron diffraction microscopy," presented at *Conference on electron microscopy*, Delft, 1949, pp. 4-5.

<sup>88</sup> Michael E. Haine, letter to D. Gabor, 14 Mar 1950.

<sup>89</sup> Dennis Gabor, letter to M. E. Haine, 14 Apr 1950.

<sup>90</sup> Dennis Gabor, "Problems and prospects of electron diffraction microscopy," presented at *Conference on electron microscopy*, Delft, 1949.

<sup>91</sup> Dennis Gabor, letter to M. E. Haine, 26 Nov 1952.

<sup>92</sup> Letter M. E. Haine to Rogers 6 Oct 1952. Rogers agreed, noting, "the analogy with communication theory is particularly clear: coherent observation being analogous to using a

---

tuned receiver which can pick up a periodic signal much below the noise level as “seen” by an aperiodic amplifier.” [Gordon L. Rogers, letter to M. E. Haine, 20 Oct 1952].

<sup>93</sup> Dennis Gabor, letter to T. E. Allibone, 22 Mar 1954. An Angstrom (Å) is 0.1 nanometer.

<sup>94</sup> T. E. Allibone, letter to D. Gabor, 26 Mar 1954

<sup>95</sup> Dennis Gabor, letter to M. E. Haine, 28 Dec 1955; Dennis Gabor, Pat. No. 2,770,166 "Improvements in and relating to optical apparatus for producing multiple interference patterns" (1956), assigned to National Research Development Corporation, UK.

<sup>96</sup> Frederik Nebeker, "Eric Ash, Electrical Engineer, an oral history conducted in 1994 by Frederik Nebeker, IEEE History Center, Rutgers University, New Brunswick, NJ, USA.," [www.ieee.org/organizations/history\\_center/oral\\_histories/transcripts/ash.html](http://www.ieee.org/organizations/history_center/oral_histories/transcripts/ash.html), last updated 25 Aug 1994; accessed 10 Nov 2004.

<sup>97</sup> Dennis Gabor, letter to G. L. Rogers, 23 May 1958. Gabor later publicly claimed prejudice on the part of microscope manufacturers, describing his microscope as “an interesting device which could not only take three-dimensional photographs, but could also observe objects with 1/10 or even 1/50 of the light which is necessary in ordinary instruments. This was offered in 1956 to British, German and American firms but nobody wanted to make it. Before the invention of the laser there was no interest in holography” [Dennis Gabor, letter to *Sunday Times*, 14 Apr 1968].

<sup>98</sup> Gordon L. Rogers, letter to S. L. Bragg, 5 Sep 1950 and Gordon L. Rogers, letter to A. Boivin, 1951.

<sup>99</sup> “The object must be *very small* compared with the “gaps”. [...] Letters don’t do so badly, ditto microscope scales, but more exacting objects would be tricky.” [Gordon L. Rogers, letter to D. Gabor, 8 Nov 1954]. Rogers’ point was that Gabor’s concept required that the object occupy only a tiny portion of the optical field so that an adequately intense undiffracted wave could mix with the diffracted portion to yield interference.

<sup>100</sup> Dennis Gabor, letter to G. L. Rogers, 25 Oct 1954.

<sup>101</sup> Gordon L. Rogers, letter to A. V. Baez, 19 Jul 1956.

<sup>102</sup> Rogers suggests that the ionosphere could be mapped using radio waves, rather than electron waves, as the first stage of wavefront reconstruction. [Gordon L. Rogers, "Diffraction microscopy and the ionosphere," draft paper, Jan 1957, Sci Mus ROGRS 4].

<sup>103</sup> P. Kirkpatrick and H. M. A. El-Sum, "Image formation by reconstructed wavefronts I. Physical principles and methods of refinement," *Journal of the Optical Society of America*, 46 (1956), .

<sup>104</sup> Albert V. Baez, by email to SFJ, 13 Mar 2003.

<sup>105</sup> T. E. Allibone, "White and black elephants at Aldermaston," *Journal of Electronics and Control*, 4 (1958), 179-92.

<sup>106</sup> T. E. Allibone, letter to D. Gabor, 13 Sep 1961.

<sup>107</sup> Dennis Gabor and W. P. Goss, "Interference microscope with total wavefront reconstruction," *Journal of the Optical Society of America*, 56 (1966), 849-58. In 1964, during the explosion of interest following the work of Emmett Leith and Juris Upatnieks at the University of Michigan, Gabor had obtained American funding to wrap up the project [Dennis Gabor and W. P. Goss, report to 1964].`