

Research Article

Redundancy Optimization of an Uncertain Parallel-Series System with Warm Standby Elements

Linmin Hu , Wei Huang, Guofang Wang, and Ruiling Tian

School of Science, Yanshan University, Qinhuangdao 066004, China

Correspondence should be addressed to Linmin Hu; linminhu@ysu.edu.cn

Received 31 January 2018; Revised 24 June 2018; Accepted 5 July 2018; Published 6 September 2018

Academic Editor: Roberto Natella

Copyright © 2018 Linmin Hu et al. This is an open access article distributed under the Creative Commons Attribution License, which permits unrestricted use, distribution, and reproduction in any medium, provided the original work is properly cited.

The redundancy optimization problem is formulated for an uncertain parallel-series system with warm standby elements. The lifetimes and costs of elements are considered uncertain variables, and the weights and volumes of elements are random variables. The uncertain measure optimization model (UMOM), the uncertain optimistic value optimization model (UOVOM), and the uncertain cost optimization model (UCOM) are developed through reliability maximization, lifetime maximization, and cost minimization, respectively. An efficient simulation optimization algorithm is provided to calculate the objective values and optimal solutions of the UMOM, UOVOM, and UCOM. A numerical example is presented to illustrate the rationality of the models and the feasibility of the optimization algorithm.

1. Introduction

The primary goal of reliability design is to improve the reliability of a system. To maintain the reliability to a higher level, the redundancy allocation is an effective method in the system design phase. While improving system reliability by a redundancy method, the cost, weight, and volume also increase. Thus, it is an important topic for system decision-makers to determine the optimal number of redundant elements under certain system constraints.

In the traditional redundancy optimization problem, various kinds of optimization models have been proposed under the assumption that the lifetimes of the elements are random variables. Due to imprecision of data for element lifetimes in certain situations, fuzzy redundancy optimization models [1–4] are then developed based on fuzzy set theory [5, 6]. Furthermore, Zhao and Liu [7] proposed three redundancy optimization models under the assumption that the lifetimes of the elements are presented as fuzzy variables. Wang and Watada [8] developed two fuzzy random redundancy allocation models for a parallel-series system when the lifetimes of the elements are treated as fuzzy random variables. Recently, some researchers have addressed reliability optimization designs

of some systems by considering interval-valued component reliability in an uncertain environment. Roy et al. [9] applied the symmetrical form of interval numbers by interval-valued parametric functional form to evaluate the optimum system reliability and system cost of the redundancy allocation problem. Zhang and Chen [10] investigated an interval multiobjective optimization problem for reliability redundancy allocation of a series-parallel system. Moreover, some researchers concentrated on some hybrid uncertainty optimization problems for system reliability [11, 12].

The probability, interval, and fuzzy theories have been widely used to handle the high level of uncertainty in various real-world applications. With the development of the research on the uncertainty phenomena, the mathematical model based on the probability, interval, and fuzzy theories is not enough to solve all problems, especially when we have no available samples but belief degree from the experts. Belief degree function is a type of distribution function for indeterminate quantity. Since it usually deviates far from the frequency, using probability theory may lead to counter-intuitive results. In this case, we should use uncertainty theory. The uncertainty theory provides a useful tool to study reliability modeling and optimization problem of systems

with human uncertainty phenomena. The basic uncertainty theory was founded by Liu [13] in 2007. It was refined by Liu [14] in 2010 based on normality axiom, duality axiom, subadditivity axiom, and product axiom. Nowadays, uncertainty theory has become a branch of mathematics for modeling human uncertainty. Many theories and applications have been done based on uncertainty theory, for example, uncertain statistics [15, 16], uncertain programming [17, 18], uncertain logic [19–21], uncertain inference [22–24], uncertain process [25–27], uncertain differential equations [28, 29], and uncertain graph [30].

The system reliability via uncertainty measure was first studied by Liu [31]. Afterwards, Liu [32] investigated reliability of redundant systems with cold and warm redundant elements based on uncertainty theory. Liu et al. [33] studied the reliability and MTTF of unrepairable systems with uncertain lifetimes. Wen and Kang [34] analyzed an uncertain random system based on chance theory which is a generalization of both probability theory and uncertainty theory. Gao et al. [35] studied the reliability of k -out-of- n systems with uncertain random lifetimes. Gao et al. [36] studied the reliability of the k -out-of- n system with uncertain weights. Zeng et al. [37] defined belief reliability as an uncertain measure due to the explicit representation of epistemic uncertainty and investigated the belief reliability for coherent systems based on minimal cut sets.

Making use of an uncertain variable as a tool to characterize the lifetimes and costs of elements, we will discuss the redundancy optimization problems for a parallel-series system with warm standby elements in this paper. In this work, three uncertain optimization models are developed, and an efficient simulation optimization algorithm is given to solve these models. In Section 2, some basic concepts and theorems concerning uncertainty theory are presented. The problem formulation of an uncertain parallel-series system is considered in Section 3. Section 4 shows the three uncertain optimization models and gives a solution approach to these models. A numerical example is provided in Section 5, and Section 6 presents a general conclusion.

2. Preliminaries

Definition 1 (see [13, 38]). Let Γ be a σ -algebra on a non-empty set Γ . A set function $\mathcal{M} : \mathcal{L} \rightarrow [0, 1]$ is called an uncertain measure if it satisfies the following axioms:

Axiom 1 (normality axiom). $\mathcal{M}\{\Gamma\} = 1$ for the universal set Γ .

Axiom 2 (duality axiom). $\mathcal{M}\{\Lambda\} + \mathcal{M}\{\Lambda^c\} = 1$ for any event Λ .

Axiom 3 (subadditivity axiom). For any countable sequence of events $\Lambda_1, \Lambda_2, \dots$, we have

$$\mathcal{M}\left\{\bigcup_{i=1}^{\infty} \Lambda_i\right\} \leq \sum_{i=1}^{\infty} \mathcal{M}\{\Lambda_i\}, \quad (1)$$

the triple $(\Gamma, \mathcal{L}, \mathcal{M})$ is called an uncertainty space.

Axiom 4 (product axiom). Let $(\Gamma_k, \mathcal{L}_k, \mathcal{M}_k)$ be the uncertainty space for $k = 1, 2, \dots$. Then, the product uncertain measure \mathcal{M} is an uncertain measure satisfying

$$\mathcal{M}\left\{\prod_{k=1}^{\infty} \Lambda_k\right\} = \bigwedge_{k=1}^{\infty} \mathcal{M}_k\{\Lambda_k\}, \quad (2)$$

where Λ_k are arbitrarily chosen events from \mathcal{L} for $k = 1, 2, \dots$, respectively.

Definition 2 (see [13]). An uncertain variable is a measure function ξ from an uncertainty space $(\Gamma, \mathcal{L}, \mathcal{M})$ to the set \mathfrak{R} of real numbers; that is, for any Borel set B of real numbers, the set

$$\{\xi \in B\} = \{\gamma \in \Gamma \mid \xi(\gamma) \in B\} \quad (3)$$

is an event.

Definition 3 (see [13]). The uncertainty distribution $\Phi(x)$ of an uncertain variable ξ is defined as

$$\Phi(x) = \mathcal{M}\{\xi \leq x\}, \quad (4)$$

for any real number x .

Definition 4 (see [13]). An uncertainty distribution $\Phi(x)$ is said to be regular if it is a continuous and strictly increasing function with respect to x at which $0 < \Phi(x) < 1$, and

$$\begin{aligned} \lim_{x \rightarrow -\infty} \Phi(x) &= 0, \\ \lim_{x \rightarrow +\infty} \Phi(x) &= 1. \end{aligned} \quad (5)$$

In addition, the inverse function $\Phi^{-1}(\alpha)$ is called the inverse uncertainty distribution of ξ .

Definition 5 (see [17]). A variable $\xi_{\text{sup}}(\alpha)$ is said to be an α -optimistic value if ξ is an uncertain variable and

$$\xi_{\text{sup}}(\alpha) = \sup \{r \mid \mathcal{M}\{\xi \geq r\} \geq \alpha\}, \quad (6)$$

where $\alpha \in (0, 1]$.

Definition 6 (see [13]). An uncertain variable ξ is said to be linear if it has a linear uncertainty distribution.

$$\Phi(x) = \begin{cases} 0, & \text{if } x \leq a, \\ \frac{x - a}{b - a}, & \text{if } a < x \leq b, \\ 1, & \text{if } x > b, \end{cases} \quad (7)$$

which is denoted by $\mathcal{L}(a, b)$. Apparently, the linear uncertain variable ξ is regular and has an inverse uncertainty distribution $\Phi^{-1}(\alpha) = (1 - \alpha)a + \alpha b$.

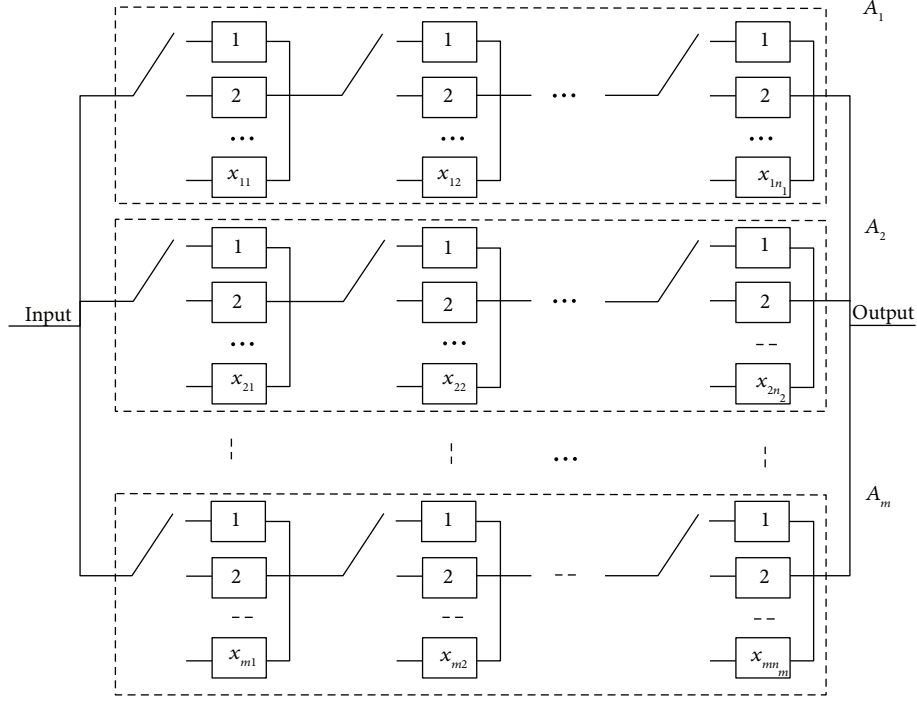

FIGURE 1: A warm standby redundant parallel-series system.

Definition 7 (see [13]). An uncertain variable ξ is said to be lognormal if $\ln \xi$ has a normal uncertainty distribution.

$$\Phi(x) = \left(1 + \exp \left(\frac{\pi(e - \ln x)}{\sqrt{3}\sigma} \right) \right)^{-1}, \quad x \in \mathcal{R}, \quad (8)$$

denoted by $\mathcal{LOGN}(e, \sigma)$, where e and σ are real numbers with $\sigma > 0$. The uncertain variable is regular, and its inverse uncertainty distribution is

$$\Phi^{-1}(\alpha) = \exp(e) \left(\frac{\alpha}{1-\alpha} \right)^{\sigma\sqrt{3}/\pi}. \quad (9)$$

Theorem 1 (see [13]). Assume that $\xi_1, \xi_2, \dots, \xi_n$ are independent uncertain variables with regular uncertainty distributions $\Phi_1, \Phi_2, \dots, \Phi_n$, respectively. If the function $f(x_1, x_2, \dots, x_n)$ is strictly increasing with respect to x_1, x_2, \dots, x_n , then $\xi = f(\xi_1, \xi_2, \dots, \xi_n)$ has an inverse uncertainty distribution $\Psi^{-1}(\alpha) = f(\Phi_1^{-1}(\alpha), \Phi_2^{-1}(\alpha), \dots, \Phi_n^{-1}(\alpha))$.

Theorem 2 (see [13]). Let ξ be an uncertain variable with a regular uncertainty distribution Φ . Then, $E[\xi] = \int_0^1 \Phi^{-1}(\alpha) d\alpha$.

Theorem 3 (see [13]). Let ξ and η be independent uncertain variables with finite expected values. Then, for any real numbers a and b , we have

$$E[\alpha\xi + b\eta] = \alpha E[\xi] + b E[\eta]. \quad (10)$$

Theorem 4 (see [13]). Assume that $\xi_1, \xi_2, \dots, \xi_n$ are independent uncertain variables with uncertainty distributions $\Phi_1, \Phi_2, \dots, \Phi_n$, respectively. Then, $\xi_1 + \xi_2 + \dots + \xi_n$, $\xi_1 \wedge \xi_2 \wedge$

$\dots \wedge \xi_n$, and $\xi_1 \vee \xi_2 \vee \dots \vee \xi_n$ have uncertainty distributions $\sup_{x_1+x_2+\dots+x_n=x} \{\min_{1 \leq i \leq n} \Phi_i(x_i)\}$, $\Phi_1(x) \vee \Phi_2(x) \vee \dots \vee \Phi_n(x)$, and $\Phi_1(x) \wedge \Phi_2(x) \wedge \dots \wedge \Phi_n(x)$, respectively.

3. Problem Formulation of an Uncertain Parallel-Series System

Consider a warm standby redundant parallel-series system composed of m subsystems A_1, A_2, \dots, A_m , and subsystem A_i consists of n_i components connected in series, as shown in Figure 1. The component j in subsystem A_i contains one original element and $x_{ij} - 1$ warm standby redundant elements, $i = 1, 2, \dots, m$ and $j = 1, 2, \dots, n_i$.

Throughout the paper, we assume the following for the warm standby redundant parallel-series system under consideration.

- (1) The system, components, and elements are only in one of two states (up state or down state) at any time.
- (2) All the elements are independent.
- (3) The system starts to work at time 0.
- (4) For each component, there is one element available.
- (5) The system or element is nonrepairable.
- (6) The standby redundant elements may deteriorate in the standby period.
- (7) The lifetime of each element is an uncertain variable, and the standby deterioration rates of all the elements in the standby period are the same constant.

- (8) Conversion switches of the standby system are absolutely reliable, and the conversion is instantaneous.
- (9) The costs of all the elements are independent uncertain variables, and the weights and volumes of all the elements are independent random variables.

3.1. Component Lifetime. According to the assumptions, the lifetime of the component j in the subsystem A_i can be expressed as

$$T_{ij}(\mathbf{x}, \xi) = \widehat{\xi}_{ij1} + \widehat{\xi}_{ij2} + \cdots + \widehat{\xi}_{ijx_{ij}}, \quad (11)$$

where

$$\begin{aligned} \mathbf{x} &= (x_{11}, x_{12}, \dots, x_{1n_1}, \dots, x_{m1}, x_{m2}, \dots, x_{mn_m}), \\ \xi &= \left(\widehat{\xi}_{111}, \widehat{\xi}_{112}, \dots, \widehat{\xi}_{11x_{11}}, \dots, \widehat{\xi}_{ij1}, \widehat{\xi}_{ij2}, \dots, \right. \\ &\quad \left. \widehat{\xi}_{ijx_{ij}}, \dots, \widehat{\xi}_{mn_m1}, \widehat{\xi}_{mn_m2}, \dots, \widehat{\xi}_{mn_mx_{mn_m}} \right), \end{aligned} \quad (12)$$

where x_{ij} represents the number of the elements in the component j for the subsystem A_i and $\widehat{\xi}_{ijx_{ij}}$ represents the working lifetime of the x_{ij} th element in the component j for the subsystem A_i , $i = 1, 2, \dots, m$ and $j = 1, 2, \dots, n_i$.

For simplicity, it is assumed that the deterioration rates of all the warm standby elements are the same constant, denoted by λ (very small number). According to [32], the working lifetime of the x_{ij} th element in the component j for the subsystem A_i is expressed as

$$\widehat{\xi}_{ijx_{ij}} = \xi_{ijx_{ij}} - \lambda \left(\widehat{\xi}_{ij1} + \widehat{\xi}_{ij2} + \cdots + \widehat{\xi}_{ij(x_{ij}-1)} \right), \quad (13)$$

where $\xi_{ijx_{ij}}$ represents the uncertain lifetime of the x_{ij} th element in the component j for the subsystem A_i from time 0 and $\widehat{\xi}_{i1} = \xi_{i1}$ (i.e., the first element starts to work at time 0). Thus, the working lifetime of all elements in the component j for the subsystem A_i can be expressed as follows:

$$\begin{aligned} \widehat{\xi}_{ij1} &= \xi_{ij1}, \\ \widehat{\xi}_{ij2} &= \xi_{ij2} - \lambda \widehat{\xi}_{ij1}, \\ \widehat{\xi}_{ij3} &= \xi_{ij3} - \lambda \left(\widehat{\xi}_{ij1} + \widehat{\xi}_{ij2} \right), \\ &\vdots \\ \widehat{\xi}_{ijx_{ij}} &= \xi_{ijx_{ij}} - \lambda \left(\widehat{\xi}_{ij1} + \widehat{\xi}_{ij2} + \cdots + \widehat{\xi}_{ij(x_{ij}-1)} \right). \end{aligned} \quad (14)$$

By (11) and (14), the lifetime of component j in the subsystem A_i can be expressed as

$$T_{ij}(\mathbf{x}, \xi) = (1 - \lambda)^{x_{ij}-1} \xi_{ij1} + (1 - \lambda)^{x_{ij}-2} \xi_{ij2} + \cdots + \xi_{ijx_{ij}}. \quad (15)$$

3.2. System Lifetime. The lifetime of subsystem A_i can be obtained by

$$\begin{aligned} T_{A_i}(\mathbf{x}, \xi) &= \bigwedge_{j=1,2,\dots,n_i} T_{ij}(\mathbf{x}, \xi) \\ &= \bigwedge_{j=1,2,\dots,n_i} \sum_{1 \leq k \leq x_{ij}} \widehat{\xi}_{ijk} \\ &= \bigwedge_{j=1,2,\dots,n_i} \sum_{1 \leq k \leq x_{ij}} (1 - \lambda)^{x_{ij}-k} \xi_{ijk}. \end{aligned} \quad (16)$$

The lifetime of the system can be determined as

$$T(\mathbf{x}, \xi) = \max \left\{ \begin{array}{l} \bigwedge_{j=1,2,\dots,n_1} \sum_{1 \leq k \leq x_{1j}} (1 - \lambda)^{x_{1j}-k} \xi_{1jk} \\ \bigwedge_{j=1,2,\dots,n_2} \sum_{1 \leq k \leq x_{2j}} (1 - \lambda)^{x_{2j}-k} \xi_{2jk} \\ \vdots \\ \bigwedge_{j=1,2,\dots,n_m} \sum_{1 \leq k \leq x_{mj}} (1 - \lambda)^{x_{mj}-k} \xi_{mjk} \end{array} \right\}. \quad (17)$$

Using (15), (16), and (17), $T(\mathbf{x}, \xi)$ can be written as

$$T(\mathbf{x}, \xi) = \max_{1 \leq i \leq m} \bigwedge_{j=1,2,\dots,n_i} \sum_{1 \leq k \leq x_{ij}} (1 - \lambda)^{x_{ij}-k} \xi_{ijk}. \quad (18)$$

4. The System Optimization Model

The purpose of redundancy optimization is to find the optimal solution $\mathbf{x} = (x_{11}, x_{12}, \dots, x_{1n_1}, \dots, x_{m1}, x_{m2}, \dots, x_{mn_m})$ (the numbers of elements in each component for each subsystem) for improving the system performances under certain constraints. In this section, three different standby redundancy optimization models are considered for different management purposes. In these models, the costs of all the elements are presented as uncertain variables and the weights and volumes of all the elements are presented as random variables.

4.1. The Uncertain Measure Optimization Model. The uncertain measure is used to define the system reliability, and the optimization objective is to maximize the uncertainty measure $\mathcal{M}\{T(\mathbf{x}, \xi) > t_0\}$ that the system lifetime is greater than or equal to the given time t_0 under the expected cost, expected weight, and expected volume constraints. In this way, the general form of the uncertain measure optimization model (UMOM) is as follows:

$$\begin{aligned} \max_{\mathbf{x}} \quad & \mathcal{M}\{T(\mathbf{x}, \xi) > t_0\} \\ \text{s.t.} \quad & E \left[\sum_{1 \leq i \leq m} \sum_{1 \leq j \leq n_i} x_{ij} c_{ij} \right] \leq c_0 \\ & E \left[\sum_{1 \leq i \leq m} \sum_{1 \leq j \leq n_i} x_{ij} w_{ij} \right] \leq w_0 \end{aligned}$$

$$E \left[\sum_{1 \leq i \leq m} \sum_{1 \leq j \leq n_i} x_{ij} v_{ij} \right] \leq v_0$$

$$x_{ij} \geq 1, x_{ij} \in N^+, i = 1, 2, \dots, m, j = 1, 2, \dots, n_i, \quad (19)$$

where c_{ij} , w_{ij} , and v_{ij} represent the uncertain cost, random weight, and random volume of each element in the component j for the subsystem A_i , respectively.

Assume that the uncertain lifetimes $\xi_{ij1}, \xi_{ij2}, \dots, \xi_{ijx_{ij}}$ ($i = 1, 2, \dots, m, j = 1, 2, \dots, n_i$) have the same uncertainty distribution $\Phi_{ij}(t)$. According to Theorem 4 and [32], the uncertain lifetime distribution functions of the subsystems A_1, A_2, \dots, A_m , denoted by $\psi_{A_1}(\mathbf{x}, t), \psi_{A_2}(\mathbf{x}, t), \dots, \psi_{A_m}(\mathbf{x}, t)$, respectively, can be obtained as

$$\begin{aligned} \psi_{A_1}(\mathbf{x}, t) &= \mathcal{M}\{T_{A_1}(\mathbf{x}, \xi) \leq t\} \\ &= \bigvee_{j=1,2,\dots,n_1} \Phi_{1j}(\mathbf{x}, t) \\ &= \bigvee_{j=1,2,\dots,n_1} \Phi_{1j}\left(\frac{\lambda t}{1 - (1 - \lambda)^{x_{1j}}}\right), \\ \psi_{A_2}(\mathbf{x}, t) &= \mathcal{M}\{T_{A_2}(\mathbf{x}, \xi) \leq t\} \\ &= \bigvee_{j=1,2,\dots,n_2} \Phi_{2j}(\mathbf{x}, t) \\ &= \bigvee_{j=1,2,\dots,n_2} \Phi_{2j}\left(\frac{\lambda t}{1 - (1 - \lambda)^{x_{2j}}}\right), \\ &\vdots \\ \psi_{A_m}(\mathbf{x}, t) &= \mathcal{M}\{T_{A_m}(\mathbf{x}, \xi) \leq t\} \\ &= \bigvee_{j=1,2,\dots,n_m} \Phi_{mj}(\mathbf{x}, t) \\ &= \bigvee_{j=1,2,\dots,n_m} \Phi_{mj}\left(\frac{\lambda t}{1 - (1 - \lambda)^{x_{mj}}}\right), \end{aligned} \quad (20)$$

where $\Phi_{ij}(\mathbf{x}, t)$ is the uncertain lifetime distribution function of the component j in subsystem A_i . The lifetime of the system has an uncertainty distribution function.

$$\begin{aligned} \Phi(\mathbf{x}, t) &= \min_{1 \leq i \leq m} \psi_{A_i}(\mathbf{x}, t) \\ &= \min_{1 \leq i \leq m} \bigvee_{j=1,2,\dots,n_i} \Phi_{ij}\left(\frac{\lambda t}{1 - (1 - \lambda)^{x_{ij}}}\right). \end{aligned} \quad (21)$$

According to the system reliability definition and duality of uncertain measure, we have

$$\begin{aligned} \mathcal{M}\{T(\mathbf{x}, \xi) > t\} &= 1 - \Phi(\mathbf{x}, t) \\ &= 1 - \min_{1 \leq i \leq m} \bigvee_{j=1,2,\dots,n_i} \Phi_{ij}\left(\frac{\lambda t}{1 - (1 - \lambda)^{x_{ij}}}\right). \end{aligned} \quad (22)$$

According to Theorem 3 and the linear operation of the expected value of the random variable, we have

$$\begin{aligned} E \left[\sum_{1 \leq i \leq m} \sum_{1 \leq j \leq n_i} x_{ij} c_{ij} \right] &= \sum_{1 \leq i \leq m} \sum_{1 \leq j \leq n_i} x_{ij} E[c_{ij}], \\ E \left[\sum_{1 \leq i \leq m} \sum_{1 \leq j \leq n_i} x_{ij} w_{ij} \right] &= \sum_{1 \leq i \leq m} \sum_{1 \leq j \leq n_i} x_{ij} E[w_{ij}], \\ E \left[\sum_{1 \leq i \leq m} \sum_{1 \leq j \leq n_i} x_{ij} v_{ij} \right] &= \sum_{1 \leq i \leq m} \sum_{1 \leq j \leq n_i} x_{ij} E[v_{ij}]. \end{aligned} \quad (23)$$

Therefore, the UMOM (19) is equivalent to

$$\begin{aligned} \max_{\mathbf{x}} \quad & \left(1 - \min_{1 \leq i \leq m} \bigvee_{j=1,2,\dots,n_i} \Phi_{ij}\left(\frac{\lambda t_0}{1 - (1 - \lambda)^{x_{ij}}}\right) \right) \\ \text{s.t.} \quad & \sum_{1 \leq i \leq m} \sum_{1 \leq j \leq n_i} x_{ij} E[c_{ij}] \leq c_0 \\ & \sum_{1 \leq i \leq m} \sum_{1 \leq j \leq n_i} x_{ij} E[w_{ij}] \leq w_0 \\ & \sum_{1 \leq i \leq m} \sum_{1 \leq j \leq n_i} x_{ij} E[v_{ij}] \leq v_0 \\ & x_{ij} \geq 1, x_{ij} \in N^+, i = 1, 2, \dots, m, j = 1, 2, \dots, n_i. \end{aligned} \quad (24)$$

4.2. The Uncertain Optimistic Value Optimization Model. If we use the system lifetime to measure the system performance, then the optimization objective is to maximize the α -optimistic value of the system lifetime $T(\mathbf{x}, \xi)$ when α is equal to the given value α_0 under the same constraints as model (19). In this way, the form of the uncertain optimistic value optimization model (UOVOM) can be expressed as

$$\begin{aligned} \max_{\mathbf{x}} \quad & t_{\mathbf{x}} \\ \text{s.t.} \quad & \mathcal{M}\{T(\mathbf{x}, \xi) > t_{\mathbf{x}}\} \geq \alpha_0 \\ & E \left[\sum_{1 \leq i \leq m} \sum_{1 \leq j \leq n_i} x_{ij} c_{ij} \right] \leq c_0 \\ & E \left[\sum_{1 \leq i \leq m} \sum_{1 \leq j \leq n_i} x_{ij} w_{ij} \right] \leq w_0 \\ & E \left[\sum_{1 \leq i \leq m} \sum_{1 \leq j \leq n_i} x_{ij} v_{ij} \right] \leq v_0 \\ & x_{ij} \geq 1, x_{ij} \in N^+, i = 1, 2, \dots, m, j = 1, 2, \dots, n_i, \end{aligned} \quad (25)$$

where $t_{\mathbf{x}}$ represents the time related to decision vector \mathbf{x} . By Theorem 1, the inverse uncertainty distribution of the system lifetime $T(\mathbf{x}, \xi)$ is

$$\Phi^{-1}(\alpha) = \max_{1 \leq i \leq m} \bigwedge_{j=1,2,\dots,n_i} \frac{1 - (1 - \lambda)^{x_{ij}}}{\lambda} \Phi_{ij}^{-1}(\alpha), \quad (26)$$

where $\Phi_{ij}^{-1}(\alpha)$ is the inverse uncertainty distribution of the lifetime of the component j in the subsystem A_i . By using the duality of uncertain measure, $\mathcal{M}\{T(\mathbf{x}, \boldsymbol{\xi}) > t_{\mathbf{x}}\} \geq \alpha$ can be replaced by $\Phi(\mathbf{x}, t_{\mathbf{x}}) \leq 1 - \alpha$ which is equivalent to $t_{\mathbf{x}} \leq \Phi^{-1}(1 - \alpha)$. According to the monotonicity of $\Phi(\mathbf{x}, t_{\mathbf{x}})$, $t_{\mathbf{x}}$ can reach its maximum when $t_{\mathbf{x}} = \Phi^{-1}(1 - \alpha)$. Therefore, the UOVOM (25) is equivalent to

$$\begin{aligned} \max_{\mathbf{x}} \quad & \Phi^{-1}(1 - \alpha_0) \\ \text{s.t.} \quad & \sum_{1 \leq i \leq m} \sum_{1 \leq j \leq n_i} x_{ij} E[c_{ij}] \leq c_0 \\ & \sum_{1 \leq i \leq m} \sum_{1 \leq j \leq n_i} x_{ij} E[w_{ij}] \leq w_0 \\ & \sum_{1 \leq i \leq m} \sum_{1 \leq j \leq n_i} x_{ij} E[v_{ij}] \leq v_0 \\ & x_{ij} \geq 1, x_{ij} \in N^+, i = 1, 2, \dots, m, j = 1, 2, \dots, n_i. \end{aligned} \quad (27)$$

4.3. The Uncertain Cost Optimization Model. In the following, we give an uncertain cost optimization model with system reliability, expected weight, and expected volume constraints. Since the cost of the system is an uncertain variable, it cannot be directly minimized. Based on the expected value of the system cost, we may minimize its expected value. Then, we have the uncertain cost optimization model (UCOM) as follows:

$$\begin{aligned} \min_{\mathbf{x}} \quad & E \left[\sum_{1 \leq i \leq m} \sum_{1 \leq j \leq n_i} x_{ij} c_{ij} \right] \\ \text{s.t.} \quad & \mathcal{M}\{T(\mathbf{x}, \boldsymbol{\xi}) > t_0\} \geq \alpha_0 \\ & E \left[\sum_{1 \leq i \leq m} \sum_{1 \leq j \leq n_i} x_{ij} w_{ij} \right] \leq w_0 \\ & E \left[\sum_{1 \leq i \leq m} \sum_{1 \leq j \leq n_i} x_{ij} v_{ij} \right] \leq v_0 \\ & x_{ij} \geq 1, x_{ij} \in N^+, i = 1, 2, \dots, m, j = 1, 2, \dots, n_i. \end{aligned} \quad (28)$$

The UCOM (28) is equivalent to

$$\begin{aligned} \min_{\mathbf{x}} \quad & \sum_{1 \leq i \leq m} \sum_{1 \leq j \leq n_i} x_{ij} E[c_{ij}] \\ \text{s.t.} \quad & \Phi^{-1}(1 - \alpha_0) \geq t_0 \\ & \sum_{1 \leq i \leq m} \sum_{1 \leq j \leq n_i} x_{ij} E[w_{ij}] \leq w_0 \\ & \sum_{1 \leq i \leq m} \sum_{1 \leq j \leq n_i} x_{ij} E[v_{ij}] \leq v_0 \\ & x_{ij} \geq 1, x_{ij} \in N^+, i = 1, 2, \dots, m, j = 1, 2, \dots, n_i. \end{aligned} \quad (29)$$

4.4. Solution Approach for the Optimization Model. It is easy to see that the models (24), (27), and (29) which are equivalent to the UMOM, UOVOM, and UCOM, respectively, are

crisp nonlinear integer programming models. An efficient simulation optimization algorithm is provided to calculate the objective values and optimal solutions of the UMOM, UOVOM, and UCOM. The main steps of the proposed algorithm are as follows:

Step 1. Set the range of the integer decision variable x_{ij} to be $[l, u]$, $i = 1, 2, \dots, m, j = 1, 2, \dots, n_i$.

Step 2. Randomly generate r integer vectors $\mathbf{x}_k = (x_{k11}, x_{k12}, \dots, x_{k1n_1}, \dots, x_{km1}, x_{km2}, \dots, x_{kmn_m})$ ($k = 1, 2, \dots, r$) from the interval $[l, u]$, and construct a matrix with r rows and $n_1 + n_2 + \dots + n_m$ columns.

$$\mathbf{X} = \begin{pmatrix} x_{111} & x_{112} & \cdots & x_{11n_1} & \cdots & x_{1m1} & x_{1m2} & \cdots & x_{1mn_m} \\ x_{211} & x_{212} & \cdots & x_{21n_1} & \cdots & x_{2m1} & x_{2m2} & \cdots & x_{2mn_m} \\ \vdots & \vdots & \vdots & \vdots & \vdots & \vdots & \vdots & \vdots & \vdots \\ x_{r11} & x_{r12} & \cdots & x_{r1n_1} & \cdots & x_{rm1} & x_{rm2} & \cdots & x_{rmn_m} \end{pmatrix}, \quad (30)$$

where the row vector $\mathbf{x}_k = (x_{k11}, x_{k12}, \dots, x_{k1n_1}, \dots, x_{km1}, x_{km2}, \dots, x_{kmn_m})$ is the possible solution vector.

Step 3. Substitute each row of the matrix \mathbf{X} into

$$\begin{aligned} \sum_{1 \leq i \leq m} \sum_{1 \leq j \leq n_i} x_{ij} E[c_{ij}] &\leq c_0, \\ \sum_{1 \leq i \leq m} \sum_{1 \leq j \leq n_i} x_{ij} E[w_{ij}] &\leq w_0, \\ \sum_{1 \leq i \leq m} \sum_{1 \leq j \leq n_i} x_{ij} E[v_{ij}] &\leq v_0, \end{aligned} \quad (31)$$

$$\begin{aligned} \mathcal{M}\{T(\mathbf{x}, \boldsymbol{\xi}) > t_{\mathbf{x}}\} &\geq \alpha_0, \\ \sum_{1 \leq i \leq m} \sum_{1 \leq j \leq n_i} x_{ij} E[c_{ij}] &\leq c_0, \\ \sum_{1 \leq i \leq m} \sum_{1 \leq j \leq n_i} x_{ij} E[w_{ij}] &\leq w_0, \\ \sum_{1 \leq i \leq m} \sum_{1 \leq j \leq n_i} x_{ij} E[v_{ij}] &\leq v_0, \end{aligned} \quad (32)$$

and

$$\begin{aligned} \mathcal{M}\{T(\mathbf{x}, \boldsymbol{\xi}) > t_0\} &> t_0, \\ \sum_{1 \leq i \leq m} \sum_{1 \leq j \leq n_i} x_{ij} E[w_{ij}] &\leq w_0, \\ \sum_{1 \leq i \leq m} \sum_{1 \leq j \leq n_i} x_{ij} E[v_{ij}] &\leq v_0 \end{aligned} \quad (33)$$

for the UMOM, UOVOM, and UCOM, respectively. We can obtain the feasible solutions and can also construct feasible solution matrixes for the three different models.

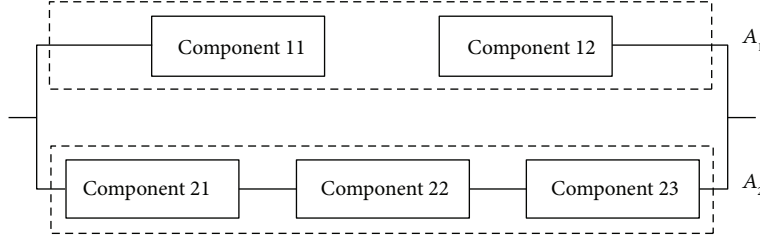

FIGURE 2: A warm standby redundant parallel-series system with two subsystems.

TABLE 1: The data of the example.

Component	11	12	21	22	23
Element lifetime	$\mathcal{LON}(5, 1)$	$\mathcal{L}(12, 16)$	$\mathcal{L}(11, 15)$	$\mathcal{LON}(5, 2)$	$\mathcal{LON}(4, 1.5)$
Element cost	$\mathcal{LON}(2, 1)$	$\mathcal{LON}(1, 0.5)$	$\mathcal{L}(8, 10)$	$\mathcal{L}(10, 12)$	$\mathcal{LON}(1.5, 0.5)$
Element weight	$U(7, 10)$	$U(8, 9)$	$U(4, 6)$	$U(2, 4)$	$U(9, 10)$
Element volume	$U(8, 9.5)$	$U(4.5, 6)$	$U(9, 10)$	$U(8, 10)$	$U(2, 4)$

Step 4. Calculate $\min_{1 \leq i \leq m} \sum_{j=1, 2, \dots, n_i} \Phi_{ij}(\lambda t / (1 - (1 - \lambda)^{x_{ij}}))$, $-\Phi^{-1}(1 - \alpha_0)$, and $\sum_{1 \leq i \leq m} \sum_{1 \leq j \leq n_i} x_{ij} E[c_{ij}]$ based on the row vectors of the feasible solution matrixes in Step 3 for the three different models, respectively. The feasible solutions that make $\min_{1 \leq i \leq m} \sum_{j=1, 2, \dots, n_i} \Phi_{ij}(\lambda t / (1 - (1 - \lambda)^{x_{ij}}))$, $-\Phi^{-1}(1 - \alpha_0)$, and $\sum_{1 \leq i \leq m} \sum_{1 \leq j \leq n_i} x_{ij} E[c_{ij}]$ the minimum are the best solutions for the three different models, respectively.

Step 5. Change r in Step 2, repeat Step 2 to Step 4, observe the changes of the objective function values obtained under different simulation times, and determine the most appropriate number of simulation r .

Step 6. Return the best solutions obtained under the value r in Step 5 as the final optimal solutions for the three different models.

5. Numerical Example

In this section, we give an illustration of the optimization models and their solutions for a warm standby redundant parallel-series system shown in Figure 2. The detailed data used in this example are those given in Table 1.

In the UMOM, we take $\lambda = 0.01$, $t_0 = 100$, $c_0 = 350$, $w_0 = 300$, and $v_0 = 250$. The lower and upper bounds of the number of the redundant elements are $l = 1$ and $u = 10$, respectively. Then, the model can be expressed as

$$\begin{aligned}
 \max_{\mathbf{x}} \quad & \left(1 - \min_{1 \leq i \leq 2} \sum_{j=1, 2, \dots, n_i} \Phi_{ij} \left(\frac{0.01 \times 100}{1 - (1 - 0.01)^{x_{ij}}} \right) \right) \\
 \text{s.t.} \quad & 12.97x_{11} + 3.09x_{12} + 9.00x_{21} + 11.00x_{22} + 5.10x_{23} \leq 350 \\
 & 8.50x_{11} + 8.50x_{12} + 5.00x_{21} + 3.00x_{22} + 9.50x_{23} \leq 300, \\
 & 8.75x_{11} + 5.25x_{12} + 9.50x_{21} + 9.00x_{22} + 3.00x_{23} \leq 250 \\
 & x_{11}, x_{12}, x_{21}, x_{22}, x_{23} \in N^+, n_1 = 2, n_2 = 3.
 \end{aligned} \tag{34}$$

TABLE 2: Simulation results with a step size of 100 in the UMOM.

Simulation times	Reliability	Error	Optimal solution	Running time (s)
100	0.8905	0.0268	(3,8,8,7,7)	0.001629
200	0.8770	0.0403	(2,7,7,7,4)	0.001390
300	0.8581	0.0592	(8,8,8,5,2)	0.001055
400	0.9101	0.0027	(3,7,7,9,1)	0.001457
500	0.9173	0	(4,7,8,10,3)	0.002060
600	0.9101	0.0027	(4,7,7,9,1)	0.002060
700	0.9101	0.0027	(5,7,8,9,1)	0.002025
800	0.9173	0	(5,8,7,10,1)	0.002624
900	0.9101	0.0027	(3,8,9,9,4)	0.002737
1000	0.9173	0	(4,7,8,10,2)	0.002670

By using an enumeration algorithm in MATLAB, the exact solution of the model (34) is (4,7,8,10,3) and the corresponding objective function value is 0.9173. That is, the components 11, 12, 21, 22, and 23 have 3, 6, 7, 9, and 2 redundant elements, respectively. They are solved in about 100 s. It is very difficult to use the enumeration algorithm to solve the optimization problem when the decision variables are very large. However, the proposed simulation optimization algorithm in Section 4.4 is very efficient. The effectiveness of the algorithm is illustrated below. Firstly, the simulation times are increased by a step size of 100. Table 2 shows the change of reliability, optimal solution, running time, and error with different simulation times, where the error represents the absolute value of the difference between the real value and the optimal value obtained by our algorithm. We can see from Table 2 that the fluctuation of the error is very obvious and the running time increases as the simulation times increase. Secondly, the simulation times are increased by a step size of 1000, and the data obtained are shown in Table 3. It can be seen from Table 3 that the system reliability is stable at 0.9173 and the error fluctuation is zero. In addition, we can see that completing

TABLE 3: Simulation results with a step size of 1000 in the UMOM.

Simulation times	Reliability	Error	Optimal solution	Running time (s)
1000	0.9173	0	(4,7,8,10,2)	0.002670
2000	0.9173	0	(3,7,7,10)	0.004696
3000	0.9173	0	(4,7,7,10,4)	0.006890
4000	0.9173	0	(4,7,7,10,2)	0.009491
5000	0.9173	0	(3,8,8,10,1)	0.007648
6000	0.9173	0	(3,8,8,10,3)	0.009877
7000	0.9173	0	(5,7,7,10,1)	0.013472
8000	0.9173	0	(3,8,9,10,2)	0.013417
9000	0.9173	0	(3,8,7,10,7)	0.014569
10000	0.9173	0	(4,7,8,10,3)	0.015909

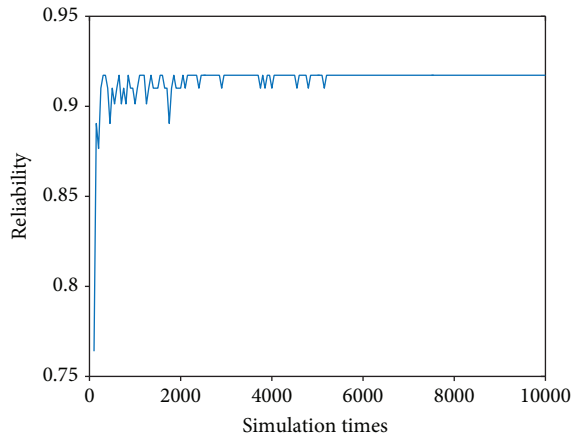

FIGURE 3: Reliability versus simulation times in the UMOM.

the computation takes very little time by using the simulation optimization algorithm. Figure 3 illustrates the objective function value (system reliability) versus simulation times. The optimal solutions for different deterioration rates are given in Table 4.

In the UOVOM, we take $\lambda = 0.01$, $\alpha_0 = 0.9$, $c_0 = 350$, $w_0 = 300$, and $v_0 = 250$. The lower and upper bounds of the number of the redundant elements are $l = 1$ and $u = 20$, respectively. Then, the model can be expressed as

$$\begin{aligned}
 \max_{\mathbf{x}} \quad & \left(\max_{1 \leq i \leq 2} \wedge_{1 \leq j \leq n_i} \frac{1 - (1 - 0.01)^{x_{ij}}}{0.01} \Phi_{ij}^{-1}(1 - 0.9) \right) \\
 \text{s.t.} \quad & 12.97x_{11} + 3.09x_{12} + 9.00x_{21} + 11.00x_{22} + 5.10x_{23} \leq 350 \\
 & 8.50x_{11} + 8.50x_{12} + 5.00x_{21} + 3.00x_{22} + 9.50x_{23} \leq 300 \\
 & 8.75x_{11} + 5.25x_{12} + 9.50x_{21} + 9.00x_{22} + 3.00x_{23} \leq 250 \\
 & x_{11}, x_{12}, x_{21}, x_{22}, x_{23} \in N^+, n_1 = 2, n_2 = 3.
 \end{aligned} \tag{35}$$

The relationship between the simulation times and the α_0 -optimistic value of system lifetime is illustrated in Figure 4 when the step size of simulation times is 5000.

It can be seen that the α_0 -optimistic value of system lifetime has a common upper bound, whose value is the optimal

TABLE 4: Optimal solutions for different deterioration rates in the UMOM.

Deterioration rate	Reliability	Optimal solution
0.01	0.9173	(4,7,8,10,2)
0.02	0.9141	(5,8,7,10,1)
0.03	0.9110	(4,7,8,10,2)
0.04	0.9077	(4,8,7,10,4)
0.05	0.9044	(4,8,7,10,5)

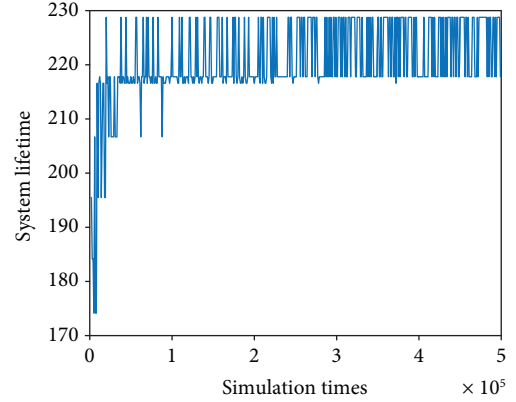

FIGURE 4: System lifetime versus simulation times in the UOVOM.

TABLE 5: Optimal solutions for different deterioration rates in the UOVOM.

Deterioration rate	System lifetime	Optimal solution
0.01	228.7692	(6,2,1,19,1)
0.02	212.3099	(5,2,1,20,2)
0.03	200.1285	(5,1,1,20,3)
0.04	183.5869	(5,1,1,20,2)
0.05	168.8518	(5,2,1,20,2)

value, and the corresponding solution is the optimal solution. The optimal solution is (6,2,1,19,1), and the maximum lifetime of the system is 228.7692. That is, the components 11, 12, 21, 22, and 23 have 5, 1, 0, 18, and 0 redundant elements, respectively. The optimal solutions and the maximum α_0 -optimistic value of system lifetime at different degradation rates are obtained in Table 5.

In the UCOM, we take $\lambda = 0.01$, $\alpha_0 = 0.9$, $t_0 = 100$, $w_0 = 300$, $v_0 = 250$, $l = 1$, and $u = 10$, then the model can be expressed as

$$\begin{aligned}
 \min \quad & \{12.97x_{11} + 3.09x_{12} + 9.00x_{21} + 11.00x_{22} + 5.10x_{23}\} \\
 \text{s.t.} \quad & \max_{1 \leq i \leq 2} \wedge_{1 \leq j \leq n_i} \frac{1 - (1 - 0.01)^{x_{ij}}}{0.01} \Phi_{ij}^{-1}(1 - 0.9) \geq 100 \\
 & 8.50x_{11} + 8.50x_{12} + 5.00x_{21} + 3.00x_{22} + 9.50x_{23} \leq 300 \\
 & 8.75x_{11} + 5.25x_{12} + 9.50x_{21} + 9.00x_{22} + 3.00x_{23} \leq 250 \\
 & x_{11}, x_{12}, x_{21}, x_{22}, x_{23} \in N^+, n_1 = 2, n_2 = 3.
 \end{aligned} \tag{36}$$

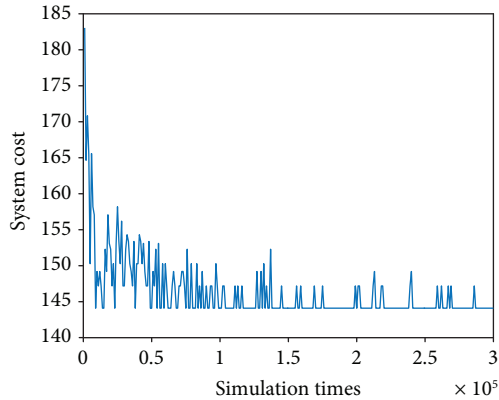

FIGURE 5: System cost versus simulation times in the UCOM.

TABLE 6: Optimal solutions for different deterioration rates in the UCOM.

Deterioration rate	System cost	Optimal solution
0.01	144.1000	(3,1,1,8,1)
0.02	155.1000	(3,1,1,9,1)
0.03	155.1000	(3,1,1,9,1)
0.04	155.1000	(3,1,1,9,1)
0.05	166.1000	(3,1,1,10,1)

The relationship between the simulation times and system expected cost is illustrated in Figure 5 when the step size of simulation times is 1000. From Figure 5, we can see that the system expected cost under different simulation times has common lower bound, whose value is the minimum expected cost of the system. The optimal solution is (3,1,1,8,1), and the corresponding minimum expected cost is 144.1000. That is, the components 11 and 22 have 2 and 7 redundant elements, respectively. The components 12, 21, and 23 have no redundant elements. The optimal solutions and the minimum expected costs at different degradation rates are given in Table 6.

6. Conclusion

In this paper, an uncertain parallel-series system with warm standby elements was investigated. Under the assumption that the element lifetime and cost are uncertain variables and the weight and volume of an element are random variables, the optimization model of warm standby redundancy for the uncertain parallel-series system was proposed. We formulated three different optimization models—UMOM, UOVOM, and UCOM—based on reliability maximization, lifetime maximization, and cost minimization, respectively. An efficient simulation optimization algorithm was designed to calculate the objective values and optimal solutions of the UMOM, UOVOM, and UCOM. The numerical example showed the rationality of the proposed models and the effectiveness of the simulation optimization algorithm. In the future, the redundancy optimization model with priority will be constructed according to the preference of the decision-maker. Also, the uncertain parallel-series system

considered in this paper is a binary system; how to model the uncertain multistate parallel-series system is another future research direction.

Data Availability

In this paper, the authors present a numerical example (the data of the elements are assumed to be uncertain or random variables in the numerical example).

Conflicts of Interest

The authors declare that there are no conflicts of interest regarding the publication of this paper.

Acknowledgments

This research work was supported in part by the Hebei Province Natural Science Foundation of China (Grant no. A2018203088), the National Natural Science Foundation of China (Grant no. 11601469), and the Science Research Project of Hebei Province Education Department (nos. ZD2017079 and QN2016016).

References

- [1] L. V. Utkin, "A new heuristic method redundancy optimization in a consecutive- k -out-of- n : F system by fuzzy probability," *Microelectronics Reliability*, vol. 33, no. 15, pp. 2197–2205, 1993.
- [2] L. V. Utkin, "Redundancy optimization by fuzzy reliability and cost of system components," *Microelectronics Reliability*, vol. 34, no. 1, pp. 53–59, 1994.
- [3] G. S. Mahapatra and T. K. Roy, "Fuzzy multi-objective mathematical programming on reliability optimization model," *Applied Mathematics and Computation*, vol. 174, no. 1, pp. 643–659, 2006.
- [4] A. Jameel and A. Z. Radhi, "Solution of fuzzy redundancy reliability optimization problem by modified penalty function method," *International Journal of Modern Mathematical Sciences*, vol. 10, no. 1, pp. 60–74, 2014.
- [5] L. A. Zadeh, "Fuzzy sets," *Information and Control*, vol. 8, no. 3, pp. 338–353, 1965.
- [6] L. A. Zadeh, "Fuzzy sets as a basis for a theory of possibility," *Fuzzy Sets and Systems*, vol. 1, no. 1, pp. 3–28, 1978.
- [7] R. Zhao and B. Liu, "Standby redundancy optimization problems with fuzzy lifetimes," *Computers & Industrial Engineering*, vol. 49, no. 2, pp. 318–338, 2005.
- [8] S. Wang and J. Watada, "Modelling redundancy allocation for a fuzzy random parallel-series system," *Journal of Computational and Applied Mathematics*, vol. 232, no. 2, pp. 539–557, 2009.
- [9] P. Roy, B. S. Mahapatra, G. S. Mahapatra, and P. K. Roy, "Entropy based region reducing genetic algorithm for reliability redundancy allocation in interval environment," *Expert Systems with Applications*, vol. 41, no. 14, pp. 6147–6160, 2014.
- [10] E. Zhang and Q. Chen, "Multi-objective reliability redundancy allocation in an interval environment using particle swarm optimization," *Reliability Engineering and System Safety*, vol. 145, pp. 83–92, 2016.

- [11] G. Li, Z. Meng, and H. Hu, "An adaptive hybrid approach for reliability-based design optimization," *Structural and Multidisciplinary Optimization*, vol. 51, no. 5, pp. 1051–1065, 2015.
- [12] Z. L. Huang, C. Jiang, Y. S. Zhou, J. Zheng, and X. Y. Long, "Reliability-based design optimization for problems with interval distribution parameters," *Structural and Multidisciplinary Optimization*, vol. 55, no. 2, pp. 513–528, 2017.
- [13] B. Liu, *Uncertainty Theory*, Springer-Verlag, Berlin, 2nd edition, 2007.
- [14] B. Liu, *Uncertainty Theory: A Branch of Mathematics for Modeling Human Uncertainty*, Springer-Verlag, Berlin, 2010.
- [15] X. Wang, Z. Gao, and H. Guo, "Delphi method for estimating uncertainty distributions," *International Journal on Information*, vol. 15, no. 2, pp. 449–459, 2012.
- [16] X. Wang, Z. Gao, and H. Guo, "Uncertain hypothesis testing for two experts' empirical data," *Mathematical and Computer Modelling*, vol. 55, no. 3–4, pp. 1478–1482, 2012.
- [17] B. Liu, *Theory and Practice of Uncertain Programming*, Springer-Verlag, Berlin, 2nd edition, 2009.
- [18] Y. Gao, "Uncertain models for single facility location problems on networks," *Applied Mathematical Modelling*, vol. 36, no. 6, pp. 2592–2599, 2012.
- [19] B. Liu, "Uncertain entailment and modus ponens in the framework of uncertain logic," *Journal of Uncertain Systems*, vol. 3, no. 4, pp. 243–251, 2009.
- [20] B. Liu, "Uncertain logic for modeling human language," *Journal of Uncertain Systems*, vol. 5, no. 1, pp. 3–20, 2011.
- [21] X. Chen and D. A. Ralescu, "A note on truth value in uncertain logic," *Expert Systems with Applications*, vol. 38, no. 12, pp. 15582–15586, 2011.
- [22] B. Liu, "Uncertain set theory and uncertain inference rule with application to uncertain control," *Journal of Uncertain Systems*, vol. 4, no. 2, pp. 83–98, 2010.
- [23] X. Gao, Y. Gao, and D. A. Ralescu, "On Liu's inference rule for uncertain systems," *International Journal of Uncertainty, Fuzziness and Knowledge-Based Systems*, vol. 18, no. 1, pp. 1–11, 2010.
- [24] Y. Gao, "Uncertain inference control for balancing an inverted pendulum," *Fuzzy Optimization and Decision Making*, vol. 11, no. 4, pp. 481–492, 2012.
- [25] K. Yao and X. Li, "Uncertain alternating renewal process and its application," *IEEE Transactions on Fuzzy Systems*, vol. 20, no. 6, pp. 1154–1160, 2012.
- [26] B. Liu, "Extreme value theorems of uncertain process with application to insurance risk model," *Soft Computing*, vol. 17, no. 4, pp. 549–556, 2013.
- [27] Y. Gao, "Variation analysis of semi-canonical process," *Mathematical and Computer Modelling*, vol. 53, no. 9–10, pp. 1983–1989, 2011.
- [28] X. Chen and B. Liu, "Existence and uniqueness theorem for uncertain differential equations," *Fuzzy Optimization and Decision Making*, vol. 9, no. 1, pp. 69–81, 2010.
- [29] Y. Gao, "Existence and uniqueness theorem on uncertain differential equations with local Lipschitz condition," *Journal of Uncertain Systems*, vol. 6, no. 3, pp. 223–232, 2012.
- [30] Y. Gao, L. Yang, S. Li, and S. Kar, "On distribution function of the diameter in uncertain graph," *Information Sciences*, vol. 296, no. 1, pp. 61–74, 2015.
- [31] B. Liu, "Uncertain risk analysis and uncertain reliability analysis," *Journal of Uncertain Systems*, vol. 4, no. 4, pp. 163–170, 2010.
- [32] W. Liu, "Reliability analysis of redundant system with uncertain lifetimes," *Information Japan*, vol. 16, no. 2, pp. 881–887, 2013.
- [33] Y. Liu, X. Li, and C. Xiong, "Reliability analysis of unrepairable systems with uncertain lifetimes," *International Journal of Security and Its Applications*, vol. 9, no. 12, pp. 289–298, 2015.
- [34] M. Wen and R. Kang, "Reliability analysis in uncertain random system," *Fuzzy Optimization and Decision Making*, vol. 15, no. 4, pp. 491–506, 2016.
- [35] R. Gao, Y. Sun, and D. A. Ralescu, "Order statistics of uncertain random variables with application to k-out-of-n system," *Fuzzy Optimization and Decision Making*, vol. 16, no. 2, pp. 159–181, 2017.
- [36] J. Gao, K. Yao, J. Zhou, and H. Ke, "Reliability analysis of uncertain weighted k-out-of-n systems," *IEEE Transactions on Fuzzy Systems*, p. 1, 2018.
- [37] Z. Zeng, R. Kang, M. Wen, and E. Zio, "Uncertainty theory as a basis for belief reliability," *Information Sciences*, vol. 429, pp. 26–36, 2018.
- [38] B. Liu, "Some research problems in uncertainty theory," *Journal of Uncertain Systems*, vol. 3, no. 1, pp. 3–10, 2009.

