

## STRATIFICATION OF GENERAL EQUILIBRIUM THEORY: A SYNTHESIS OF RECONSTRUCTIONS

### 1. INTRODUCTION

A number of authors have already tried to reconstruct general equilibrium theory (GET) in a structuralist way, in particular, following the order of appearance, Händler (1980), Balzer (1982), Haslinger (1983) and Hands (1985a). However, in view of their mutual criticism, see the papers referred to and in addition Balzer (1985) and Hands (1985b), this has thus far not led to a generally accepted reconstruction.

In this paper we will present a new attempt. However, we will not introduce a new point of view which is incompatible with those already published. Instead we will argue that it is possible to reconcile main points of the existing reconstructions, provided one is prepared to introduce a stratification between the individual and the collective level.

Leaving out production, as is usual in the earlier papers, this leads to reconstructions of what we call individual demand theory (IDT) and collective demand theory (CDT) and their mutual relation: Sections 2, 3 and 4 respectively. In Section 5 we compare our synthetic reconstruction with the earlier ones, with special emphasis on features we did not want to take over.

Beside overlooking a fruitful distinction of levels the controversy is certainly also caused by the fact that most authors tried to do justice, in dogmatic structuralist lines, to theoretical and applied economics at the same time. In this respect we have followed economists, who used to make a sharp distinction. Then it becomes plausible to start with theoretical economics. More precisely, Sections 2, 3 and 4 claim to give reconstructions of GET (without production), as far as it is a theory developed by theoretical economists. In Section 6 we elaborate on this point. We will argue that 'theoretical-GET' is another illustration of Hamminga's view on structure and development of economic theories. In line with this, we will point out an interesting partial analogy between the goals and methods of theoretical economists and natural scientists.

In Section 7 we try to reconstruct the intended applications and the empirical claim related to exchange prices and exchanged amounts as they occur in applied economics. It turns out that there is not a strong relation with collective demand theory (CDT). In Section 8 we formulate the theoretically possible intended applications and the empirical claim as they are suggested by CDT seen from a structuralist point of view. In Section 9 we do the same for individual demand theory (IDT), where we distinguish between exchange- and interview-applications. In Section 10 we sketch the main things to be done to prove the theorem that the individual (exchange-) claim of IDT implies the collective claim of CDT. Section 11 makes some final remarks.

We conclude this introduction with a general remark about the value of (undogmatic) structuralist reconstructions of theories in general and economic theories in particular. Reconstructions may occasionally suggest new lines of research, but this is not the first goal of reconstructing. An adequate reconstruction will, by definition, not produce new insights in the object of the discipline in question, i.e., it will not produce new theories, but as a rule it will produce more insight in the existing theories. The latter is the primary objective and its results may first of all be assumed to be useful in the didactics of the discipline, in particular in advanced textbooks. Of course, beside this, more insight in existing theories may, but need not, be helpful in solving conceptual and empirical problems as well as in the further development of these theories.

Like most other scientific theories, economic theories are seldom presented in a maximally transparent way. Concerning GET, we hope to increase its transparency.

## 2. INDIVIDUAL DEMAND THEORY

We start with presenting the class of proper models of individual demand theory (IDT). Later we will define classes of *incomplete* structures. Classes of definitions are always essentially mathematical conditions, followed by their intended meaning in the present context and possibly by some notation convention.

**DEFINITION 1.1.**  $\langle D, G, e, u, d \rangle$  is a *model of individual demand theory* ( $\in$  IDT) iff

- (I.1)  $D$  is a non-empty, finite set (set of individuals)  
 $i$ : index over  $D$
- (I.2)  $G$  is a non-empty, finite set (set of types of goods)  
 $j$ : index over  $G$ ,  $n$ : size of  $G$
- (I.3)  $e: D \times G \rightarrow \mathbb{R}_0^+$  (individual initial  
 $e_{ij}$ :  $i$ 's initial endowment of good  $j$  endowment)
- (I.4)  $u: D \times (\mathbb{R}_0^+)^n \rightarrow \mathbb{R}$  (individual utility  
 $u_i[y]$ :  $i$ 's utility of quantity vector (consumption bundle)  
 $y = \langle y_1, \dots, y_j, \dots, y_n \rangle$
- (I.5)  $d: D \times G \times (\mathbb{R}_0^+)^n \rightarrow \mathbb{R}$  (individual excess  
 $d_{ij}(q)$ :  $i$ 's excess demand (supply, if negative) of good  $j$  at  
 price vector  $q = \langle q_1, \dots, q_j, \dots, q_n \rangle$  demand function)
- (I.6) *commodity constraint*:<sup>1</sup> for all  $i, j$  and  $q$ :  $e_{ij} + d_{ij}(q) \geq 0$   
 (one cannot supply more than one has)
- (I.7) *budget constraint*: for all  $i$  and  $q$ :  $\sum_j q_j d_{ij}(q) \leq 0$   
 (nobody's total endowment value can increase (hence, nor decrease))
- (I.8) *utility constraint*:  $u$  is continuous and strictly quasi-concave  
 with respect to each type of good
- (I.9) *utility maximization*: for all  $\delta$  satisfying 5, 6 and 7 and for  
 all  $i$  and  $q$ :  
 $u_i[e_{i1} + \delta_{i1}(q), \dots, e_{ij} + \delta_{ij}(q), \dots, e_{in} + \delta_{in}(q)]$   
 $\leq u_i[e_{i1} + d_{i1}(q), \dots, e_{ij} + d_{ij}(q), \dots, e_{in} + d_{in}(q)]$

Assuming that the reader is familiar with all ingredients of the definition, we restrict ourselves to some structural remarks. The first five axioms define the mathematical status of the five components. Axioms (I.6) and (I.7) impose further constraints on the demand function in relation to the initial endowment. Axiom (I.8) makes the utility function manageable. Finally, Axiom (I.9) relates demand, in combination with initial endowment, to utility in the standard way.

The different roles of these axioms suggest many possibilities of defining classes of incomplete structures. The following three classes are partly inspired by structuralist practice and partly by theorem directed considerations. According to standard structuralistic practice we define potential models as follows

DEFINITION 1.2.  $\langle D, G, e, u, d \rangle$  is a *potential* model of IDT ( $\in \text{IDT}_p$ ) iff (I.1), (I.2), (I.3), (I.4) and (I.5) hold.

From the standard structuralist point of view it would now be plausible to define *partial* potential models by throwing the (relatively) theoretical components out of the potential models. However, at this point we do not want to deal with the question whether or not demand and/or utility are theoretical terms. In contrast, we want to focus on distinctions which give a clear view on the kind of theorems that are proved by theoretical economists. In the present context the following

DEFINITION 1.3.  $\langle D, G, e, u \rangle$  is a *restricted* model of IDT ( $\in \text{IDT}'$ ) iff (I.1), (I.2), (I.3), (I.4) and (I.8) hold.

is pressing itself because of a well-known theorem which reads in our terms:

THEOREM 1. If  $\langle D, G, e, u \rangle \in \text{IDT}'$  then there is precisely one  $d$  such that  $\langle D, G, e, u, d \rangle \in \text{IDT}$ .

In view of Definition 1.3 it is plausible to define, now again in structuralistic lines:

DEFINITION 1.4.  $\langle D, G, e, u \rangle$  is a *potential restricted* model if IDT ( $\in \text{IDT}'_p$ ) iff (I.1), (I.2), (I.3) and (I.4) hold.

### 3. COLLECTIVE DEMAND THEORY

It is frequently said that GET is essentially a theory of markets, not of individuals. This section will illustrate this claim. Again we start with proper models.

DEFINITION 2.1.  $\langle G, z, p \rangle$  is a *model of collective demand theory* (CDT) iff

- (C.1)  $G$  is a non-empty, (set of types of goods)  
finite set of size  $n$
- (C.2)  $z: G \times (\mathbf{R}_0^+)^n \rightarrow \mathbf{R}$  (collective excess demand functions)  
 $z_j$ : excess demand of good  $j$  at price vector  $q$ .
- (C.3)  $p \in (\mathbf{R}_0^+)^n$ ,  $p \neq 0$  (equilibrium price vector).

- (C.4) *continuity axiom*:  $z$  is continuous with respect to each price component.
- (C.5) *proportionality axiom*: for all  $q \in (\mathbb{R}^+)^n$  and  $\alpha \in \mathbb{R}^+$   $z(q) = z(\alpha q)$ . (Demand does not change if all prices multiply by a constant).
- (C.6) *collective budget constraint*: for all  $q \in (\mathbb{R}^+)^n$   $\sum_j q_j \times z_j(q) = 0$  (the value of the total endowment does not change, Walras' axiom).
- (C.7) *equilibrium axiom*: for all  $j$   $z_j(p) = 0$  or  $(z_j(p) < 0$  and  $p_j = 0)^2$ . (Demand equals supply, with room for excess supply of 'free goods').

The following definitions are motivated in the same way as Definition 1.2, 1.3 and 1.4.

DEFINITION 2.2.  $\langle G, z, p \rangle$  is a *potential* model of CDT ( $\in \text{CDT}_p$ ) iff (C.1), (C.2) and (C.3) hold.

DEFINITION 2.3.  $\langle G, z \rangle$  is a *restricted* model of CDT ( $\in \text{CDT}'$ ) iff (C.1), (C.2), (C.4), (C.5) and (C.6) hold.

DEFINITION 2.4.  $\langle G, z \rangle$  is a *potential* restricted model of CDT ( $\in \text{CDT}'_p$ ) iff (C.1) and (C.2) hold.

Again, 'restriction' has nothing to do with a distinction between theoretical and non-theoretical terms, but is directed to a theorem, in this case:

THEOREM 2. If  $\langle G, z \rangle \in \text{CDT}'$  then there is at least one  $p \in (\mathbb{R}^+)^n$  such that  $\langle G, z, p \rangle \in \text{CDT}$ .

This theorem states that restricted models of CDT are specific enough to guarantee the existence of a model of CDT. But a restricted model does not yet guarantee that a corresponding model is unique. To obtain (relative) uniqueness we have to specialize as follows

DEFINITION 3.1.  $\langle G, z, p \rangle$  is a *special model* of CDT ( $\in \text{SCDT}$ ) iff

$\langle G, z, p \rangle \in \text{CDT}$  and

(C.8) *gross substitutability*: for all  $q \in (\mathbb{R}_0^+)^n$   $\delta z_j(q)/\delta q_k > 0$  for  $j \neq k$ . (Increase of price of some good favours demand of all others goods).

DEFINITION 3.2.  $\langle G, z \rangle$  is a *restricted special model of CDT* ( $\in \text{SCDT}'$ ) iff  $\langle G, z \rangle \in \text{CDT}'$  and (C.8).

THEOREM 3. If  $\langle G, z \rangle \in \text{SCDT}'$  then there is, (in view of (C.5)) apart from a constant factor, precisely one  $p \in (\mathbb{R}_0^+)^n$  such that  $\langle G, z, p \rangle \in \text{SCDT}$ .

#### 4. RELATION BETWEEN IDT AND CDT

The relation between IDT and CDT is easy to describe in terms of the following plausible bridge definition of individual and collective excess demand.

DEFINITION 4 (*aggregation bridge*). If  $\langle D, G, d \rangle$  satisfies (I.1), (I.2) and (I.5) then the collective excess demand  $z_j(q)$  of good  $j$  at price vector  $q$  is  $\sum_i d_{ij}(q)$ , which gives rise to the *collective excess demand function*  $z^{(D,G,d)}: G \times (\mathbb{R}_0^+)^n \rightarrow \mathbb{R}$ .

The following 'upward theorems' are both plausible and easy to prove.

THEOREM 4 ( $4^p$ ). If  $\langle D, G, e, u, d \rangle \in \text{IDT}$  ( $\text{IDT}_p$ ) then  $\langle G, z^{(D,G,d)} \rangle \in \text{CDT}'$  ( $\text{CDT}'_p$ ).

At this point it is interesting to recall that Theorem 2 stated that every restricted model of CDT can be extended with a price vector to a model of CDT. Theorem 4 states on its turn that all the assumptions concerning collective excess demand functions, which are mentioned in  $\text{CDT}'$ , can be derived from 'more fundamental' assumptions concerning individual behaviour. Thus, Theorems 2 and 4 together provide explicit illustrations of the 'tendency implicit in price theory, particularly in its mathematical versions, to deduce all properties of aggregate behaviour from assumptions about individual economic agents' (Arrow (1968, p. 382)).

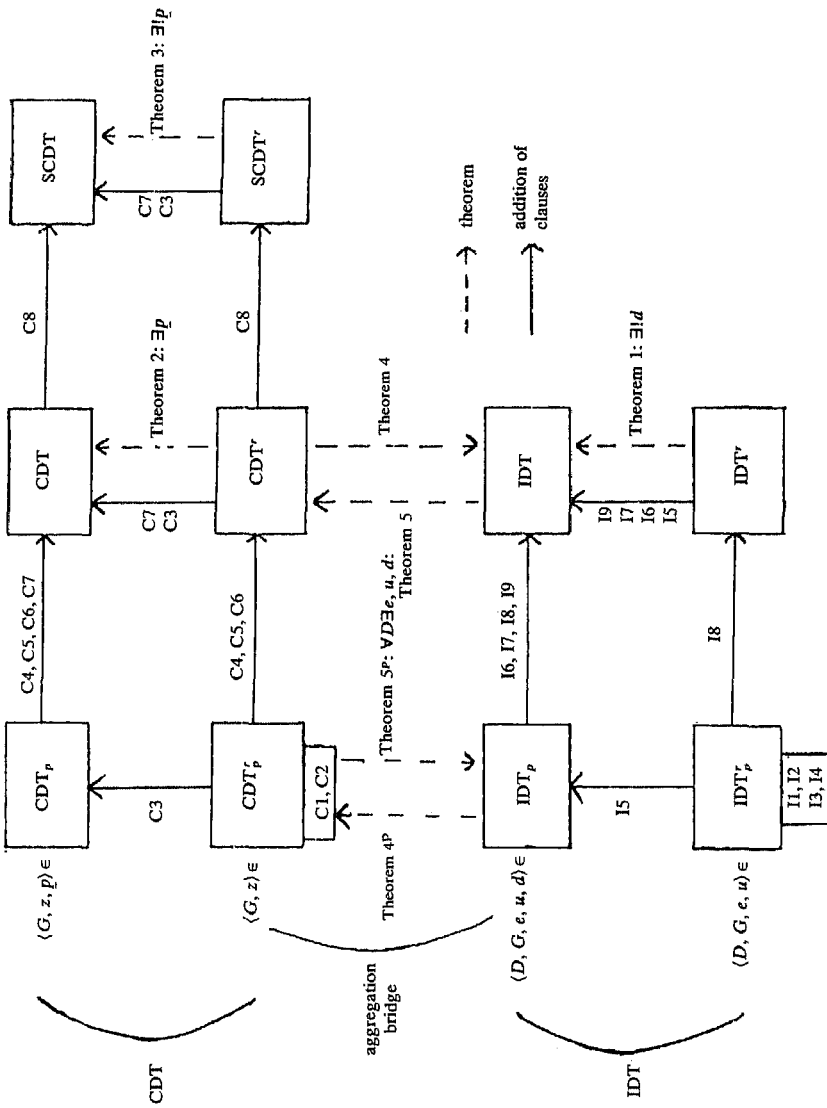

Fig. 1. A survey of individual and collective demand theory and their mutual relation.

Less trivial than the upward theorems are the 'downward theorems', at least the (restricted) model version, which was proved, among others, by Sonnenschein (1972).

**THEOREM 5** ( $5^p$ ). If  $\langle G, Z, \rangle \in \text{CDT}'$  ( $\text{CDT}'_p$ ) then for all non-empty, finite  $d$  there are  $e$ ,  $u$ , and  $d$  such that  $z = z^{(D, G, d)}$  and  $\langle D, G, e, u, d \rangle \in \text{IDT}$  ( $\text{IDT}_p$ ).

In words, given a restricted model of *collective* demand theory it is always possible to think behind this model a model of *individual* demand theory for a given set of individuals.

Now we are in the position to give a complete survey of individual and collective demand theory, and their mutual relation: see Figure 1.

##### 5. COMPARISONS TO EARLIER RECONSTRUCTIONS

In recent years different authors have proposed different ways to reconstruct general equilibrium theory without production; see e.g. Händler (1980), Balzer (1982, 1985), Haslinger (1983) and Hands (1985a). From the point of view of our two-level reconstruction we are able to put earlier controversies in a proper context. Despite some differences the reconstructions by Balzer and Haslinger share the emphasis on the individual part of GET. Hands, on the other hand, emphasized that GET is a theory about prices in competitive markets, although he mentions the underlying utility maximization in an indirect way by referring to the result of Debreu (1974), which is related to the result of Sonnenschein (1972), to which we referred in the context of Theorem 4. All three authors hold different opinions with respect to the question which concept of GET is the central and crucial one. Balzer (1982) argued that the utility function is the crucial concept of GET. According to Haslinger the individual demand function has to be considered as such, while Hands poses that the market excess demand function has to be viewed as the central and crucial concept. In our analysis everything is falling into its proper position. Utility is the central concept of IDT, the market excess demand function is the central concept of CDT, with the individual excess demand function mediating between them.

The second main topic in the earlier papers on reconstruction of



GET concerns the question whether market clearing (which is implied by our (C.7)) is a basic element of a model of GET or whether it has to be seen as a specialization. Balzer (1982) distinguishes between equilibrium distributions and market clearing. He sees market clearing as a specialization of GET, while maintaining that a set of equilibrium distributions, i.e., a set containing all distributions at which individuals maximize their utility, belongs to a model of GET. It is important to note that Balzer imposes two constraints on utility maximization: the usual budget constraint and a so-called consumption set, which asserts that collective demand can not be greater than the total amount existing in the economic system. Balzer's presentation with respect to this point is rather strange. (1) The second Theorem of Welfare Economics shows that every Pareto optimal state (roughly speaking a state at which all individuals are utility maximizers) can be supported by a market clearing situation. Market clearing is thus more or less implied by Balzer's equilibrium distributions, hence it cannot be treated as a specialization of GET. (2) Balzer's consumption set is quite similar to the requirement of market clearing (our Axiom (C.7)). He thus imposes a kind of 'market constraint' on utility maximizing behaviour of individuals so that it is (again) not clear why he treats market clearing also as a specialization. Balzer (1985)'s distinction between 'equilibrium<sub>real</sub>' and 'equilibrium<sub>get</sub>' will be discussed implicitly by treating the accounts of the market clearing condition by Haslinger and Hands.

Haslinger and Hands see the notion of an equilibrium in the context of GET as identical to the market clearing condition. Haslinger poses that market clearing is a basic element of GET, whereas Hands asserts that it is a specialization of GET. Haslinger (1983, p. 123) points out that 'equilibrium theorists... restrict their attention to Walrasian equilibrium states only' and that 'all laws of GET exclusively apply to this subset of states'. Hands (1985a, p. 213), on the other hand, stresses the importance of adjustment processes. In our point of view both positions can be reconciliated if a proper distinction is made between theoretical and more applied research with respect to GET. In the theoretical literature a good deal of discussion is concerned with adjustment processes and the characterization of the set of equilibrium states of the system. Results on adjustment processes are not very promising and we agree with Haslinger that economists have not much to say about such processes. In fact we have not treated

specializations in which adjustment processes are analyzed. Existence proofs show that the set of equilibrium states of the system is not empty, i.e., under suitable assumptions one can show that the uncoordinated actions of self interested individuals need not (necessarily) lead to chaos. Thus, the non-emptiness of the set of equilibrium states of the system is central to GET and it is curious that Hands introduces the existence of an equilibrium set of prices as a specialization, because this existence is already implied by his axioms (D.1-5), (D.2-2) and (D.2-3) (in our reconstruction (C.4), (C.5) and (C.6)). However, the non-emptiness of the set of equilibrium states of the system does not guarantee at all that an actual state of an economy is an equilibrium state. Nevertheless, if GET is used in applied research actual (observed) states of the economy are usually identified as equilibrium states of the system. But this does not mean that the identification procedure is a central element of theoretical research with respect to GET. Thus, Haslinger is wrong in interpreting the equilibrium axioms of theoretical research as asserting that actual states of a concrete economy are equilibrium states. We elaborate further on the distinction between theoretical and applied research in the Sections 6 and 7.

#### 6. THEORETICAL ECONOMICS: ITS GOALS AND METHODS

Hamminga (1982, 1983) claims that a main activity of theoretical economists is to prove so-called 'interesting theorems' on the basis of an ordered set of fixed and variable conditions. In particular, they aim to prove such a theorem for a growing number of conceptually possible situations by four strategies: field-extension, weakening of conditions, alternative conditions and conditions for conditions. He arrives at this tentative view on especially neo-classical economics by a case study of (the development of) the theory of international trade.

The presented partial analysis of GET highlights that GET is grist to the mill of Hamminga. In particular, Theorems 1, 2, 3, and 5 are examples of theorems which are certainly found to be interesting by economists. Moreover, there are many possibilities to illustrate the strategies. We will confine ourselves to one example.

The gross-substitutability specialization we have defined in Section 3 is the most well-known specialization under which uniqueness of the equilibrium price vector can be proved. Wald (1936) has established

this result for the first time. However, Arrow and Hurwicz (1960), among others in the late fifties and in beginning of the sixties, have proved that uniqueness also holds under weak gross substitutability and connectedness, which is a clear case of 'weakening of conditions', because a gross substitutability economy is certainly connected.

Economists consider successful application of one of the strategies as (theoretical) progress. According to Hamminga they do so because the new result increases the plausibility that the interesting theorem is true in the actual world. This may be faithful to the actual intentions of economists, but we do not claim that these strategies are functional for these intentions.

Be this as it may, we like to draw attention to a formal analogy between progress in the natural sciences and the described type of theoretical progress in economics. The analogy is particularly pressing as far as the latter type of progress concerns existence and uniqueness theorems. Hence, we will restrict the description of the analogy to such theorems, leaving room for the plausible possibility to extend the analogy to other types of interesting theorems.

The general situation may now be described as follows. Defined is a set of potential models  $M_p$ , a set of restricted potential model  $M_p^r$ , a restriction function  $\rho$  from  $M_p$  into  $M_p^r$  and a set of models  $M$ , being a subset of  $M_p$ .

Existence and uniqueness theorems deal with a *scope*  $S$ , being a subset of  $M_p^r$ , about which they claim respectively:

(ET) (Existence Theorem): if  $x \in s$  then  $\exists y \in M \rho(y) = x$

(UT) (Uniqueness Theorem): if  $x \in s$  and  $y, y' \in M, \rho(y) = \rho(y') = x$  then  $y = y'$

(EUT) (ET and UT); if  $x \in s$  then  $\exists^1 y \in M \rho(y) = x$ .

Theorems 2 and 5 are clear examples of ET and Theorem 1 and 3 of EUT.

Of course, the ultimate targets of these theorems are the largest scopes for which the theorem can be proved. They are the crucial unknowns and research is directed to approach them. At this point the analogy becomes relevant. In Kuipers (1982) it is argued that the basic type of truth approximation in the natural sciences consists of attempts to characterize the unknown set  $X$  of empirical possibilities of the context. Now it is plausible to define that a theory, with class of models,  $S_2$  is *progressive* with respect to a theory  $S_1$  if and only if the

symmetric difference between  $S_2$  and  $X$  (defined as  $(S_2 - X) \cup (X - S_2)$ ) is a proper subset of that between  $S_1$  and  $X$ . For the (easy to check) special case that  $S_1$  is a proper subset of  $S_2$  ( $S_1 \subset S_2 \subseteq X$ ), it is possible to speak of *cumulative progress*.

By analogy, economists claim (cumulative) progress under the same conditions, where  $X$  is now interpreted as a target set described above. However, economists are in one important respect in an advantageous position. In the natural sciences  $X$  is always primarily an empirically circumscribed set and, hence, it is never possible to check progress-claims in a straightforward way. In contrast, the target sets in theoretical economics are basically mathematically circumscribed sets. This has the indirect consequence that, as far as economists do not make mistakes in their proofs, they can be certain about claims of cumulative progress. For in that case it is only necessary to check two proofs, in addition to whether scope  $S_1$  is indeed a proper subset of scope  $S_2$ .

#### 7. APPLIED ECONOMICS

From the structuralist point of view a plausible question is what are the intended applications of IDT and CDT, and hence what are their empirical claims.

Because most applications are on the market level we start with CDT. Moreover, we will first try to answer the two questions in a pragmatic way, i.e., without bothering about the particular structuralist meaning of intended applications and the empirical claim, but as faithful as possible to what applied economics are doing.

The pragmatic definition of intended applications has to include time and collective income, which has the following background. One of the main problems associated with applying general equilibrium theory to concrete events is that there is no time involved in the theory, while concrete economies are constantly changing in time. Applied economists deal with this problem by relating all variables at the collective level to time. However, if nothing changes at the individual level, collective excess demand functions do not change either, and equilibrium prices and exchanged amounts are fixed in all distinguished time periods. One way to avoid this rather implausible consequence is to pose that initial endowments change from period to period. The operational counterpart of initial endowments at the

collective level is the collective income, i.e., the money value of total initial endowments. (Distribution effects, i.e., effects arising from different distributions of total initial endowments over individuals, are thus neglected.) Moreover, applied economists used to treat collective income as exogenous relative to exchange prices and exchanged amounts.

In the light of this we will define the intended applications and the empirical claim of what we will call applied collective demand theory (ACDT).

For convenience we will generally assume that  $G$  is a finite set of types of goods,  $T$  is a finite, ordered set of time periods.

DEFINITION 5.  $\langle T, G, y, p, f \rangle$  is a possible sequence of intended applications of ACDT iff

- (1)  $y: T \rightarrow \mathbb{R}_0^+$  (collective income)
- (2)  $p: T \rightarrow (\mathbb{R}_0^+)^n$  (exchange prices)
- (3)  $f: T \times G \rightarrow \mathbb{R}_0^+$  (exchange amounts).

It has to be said that the set of intended applications has a pragmatic nature. It is not the case that economists regard *all* tuples  $\langle T, G, y, p, f \rangle$  as intended applications, but instead all intended applications have the form as outlined in Definition 5. Economists do not fix a set of intended applications of a theory. Instead they adapt an (extreme) instrumentalistic point of view by applying their theories to all kinds of situations and look 'how good they will do'. If a theory does not give an accurate picture of a situation, then economists do *not* conclude that the theory is falsified, but they simply pose that the theory is apparently not appropriate to deal with the situation at hand.

Now, applied economists do not apply CDT to the defined sequence of intended applications, but another theory, viz. a theory of which the models specify distinct demand and supply functions that are linear functions of normalized prices and collective income and that are moreover related in time.

DEFINITION 6.  $\langle T, G, y, p, d, s \rangle$  is a sequence of related models of ACDT iff

- (1)  $y: T \rightarrow \mathbb{R}_0^+$  (collective income)
- (2)  $p: T \rightarrow (\mathbb{R}_0^+)^n$  (equilibrium prices)

- (3)  $d^3: T \times G \times (\mathbb{R}_0^+)^n \rightarrow \mathbb{R}_0^+$  (collective demand)  
 $s: T \times G \times (\mathbb{R}_0^+)^n \rightarrow \mathbb{R}_0^+$  (collective supply)
- (4) there are coefficient vectors  $\alpha^d, \alpha^s, \beta^d, \beta^s, \gamma^d, \gamma^s$ , with  $\beta_j^d - \beta_j^s > 0$  for all  $j$ , such that for all  $t, j$  and  $q$
- $$d_j^t(q) = \alpha_j^d + \beta_j^d \cdot q_j / \sum_k q_k + \gamma_j^d \cdot y^t$$
- $$s_j^t(q) = \alpha_j^s + \beta_j^s \cdot q_j / \sum_k q_k + \gamma_j^s \cdot y^t$$
- (5)  $d_j^t(p^t) = s_j^t(p^t)$  for all  $t$  and  $j$

Applied economists do not claim that, in our terms, the intended applications fit perfectly into models with the related linear form specified in Definition 6.4, but they leave always room for disturbance terms. We will not write this out, but we will just hint upon this by talking about "approximately" in the following definition.

**DEFINITION 7.** *Empirical claim of ACDT with respect to an actual sequence of intended applications of ACDT  $\langle T, G, y, p, f \rangle$ :*

there are demand and supply functions  $d$  and  $s$  such that  $\langle T, G, y, p, d, s \rangle$  is a sequence of approximately related models of ACDT such that for all  $t$ :

$$f^t = d^t(p^t) (= s^t(p^t)).$$

It is clear that  $d$  and  $s$  are determined by using the claim: hence, in structuralist terms,  $d$  and  $s$  are treated as theoretical functions of ACDT, whereas  $y, p$  and  $f$  are non-theoretical with respect to ACDT. (See Janssen (1987) for some nuances with respect to this point. His remarks in the context of macroeconomics are also valid for GET.)

The intriguing question now is of course what this has to do with CDT. It is our impression that neither applied nor theoretical economists are very much interested in this question, whereas both sides could profit from an answer.

It is easy to check that clause 4 of Definition 6 is such that the excess demand function  $z^t$  (of course defined as  $d^t - s^t$ ) satisfies (C.4), (C.5) and (C.8) of (S)CDT. Moreover, clause 5 guarantees that  $z^t$  satisfies (C.7) for  $p^t$ . However, although  $z^t$  satisfies (C.6) trivially for  $p^t$ , due to clause 5,  $z^t$  will not automatically satisfy (C.6) for all price-vectors, to say the least. By consequence, ACDT is certainly not just a specialization of CDT, and hence Theorem 2 and Theorem 3 cannot yet be used.

We do not know whether (C.6) together with the other CDT-conditions can be satisfied at all by models of ACDT in the sense of Definition 6. We only know of functions satisfying all CDT-conditions, including (C.6), which do clearly not satisfy the specific linearity condition 4 of Definition 6. The question of the joint satisfiability does not seem to interest theoretical economists very much, and applied economists do not seem to bother about it. In our opinion, however, it is an intriguing question for further research.

8. A PLAUSIBLE CLAIM OF CDT

Let us now forget about standard applied economics and concentrate on the intended applications and empirical claims as they are suggested by CDT and IDT if one looks from a structuralist point of view.

We start with CDT and we will immediately focus on special models: SCDT.

DEFINITION 8.  $\langle T, G, p, f \rangle$  is a possible sequence of intended applications of SCDT iff

- (1)  $p: T \rightarrow (\mathbb{R}_0^+)^n$  (exchange prices)
- (2)  $f: T \times G \rightarrow \mathbb{R}_0^+$  (exchanged amounts)

DEFINITION 9.  $\langle T, G, d, s \rangle$  is a sequence of d/s-models of SCDT' iff

- (1)  $d/s: T \times G \times (\mathbb{R}_0^+)^n \rightarrow \mathbb{R}$  (collective demand/supply)
- (2)  $\langle G, d^i - s^i \rangle \in \text{SCDT}'$  (i.e., (C.1, 2, 4, 5, 6, 8)  
(restricted special models of CDT)

DEFINITION 10.  $\langle T, G, d, s, p \rangle$  is a sequence of d/s-models of SCDT iff

- (1)  $d/s: T \times G \times (\mathbb{R}_0^+)^n \rightarrow \mathbb{R}$  (collective demand/supply)
- (2)  $p: T \rightarrow (\mathbb{R}_0^+)^n$  (equilibrium prices)
- (3)  $\langle G, d^i - s^i, p^i \rangle \in \text{SCDT}$  (i.e., + (C.3, 7)  
(special models of CDT)

It is plausible to call  $d^i(p^i)$  of Definition 10 (collective) equilibrium

demand and  $s'(p')$  (collective) equilibrium supply. Theorem 3 now implies that a sequence  $\langle T, G, d, s \rangle$  satisfying Definition 9 generates a unique sequence  $\langle T, G, d, s, p_* \rangle$  satisfying Definition 10. This will be used in the claim of SCDT with respect to an actual sequence of intended applications: the goods are exchanged at equilibrium prices in the corresponding equilibrium amounts generated by some sequence of restricted  $d/s$ -models. Formally:

DEFINITION 11. *Empirical claim of SCDT* with respect to an actual sequence of intended applications of SCDT  $\langle T, G, p, f \rangle$ :

there are demand and supply functions  $d$  and  $s$  such that  $\langle T, G, d, s \rangle$  is a sequence of  $d/s$ -models of SCDT' such that the (according to Theorem 3) generated unique sequence of  $d/s$ -models of SCDT  $\langle T, G, d, s, p_* \rangle$  is such that for all  $t$

$$\begin{aligned} p^t &= p_*^t \\ f^t &= d^t(p_*^t) (= s^t(p_*^t)) \end{aligned}$$

Like in Section 7, it is clear that  $d$  and  $s$  are determined by using the claim: hence,  $d$  and  $s$  are treated as theoretical functions of SCDT, whereas  $p$  and  $f$  are clearly non-theoretical with respect to SCDT. Finally,  $p_*$  is equated with  $p$  by the claim of SCDT and hence it is theoretical with respect to SCDT. However, it may also be said to be "less theoretical than"  $d$  and  $s$ , for  $p_*$  is, in combination with  $f$ , certainly not enough to determine  $d$  and  $s$ , whereas  $d$  and  $s$  determine  $p_*$ , due to Theorem 3, uniquely.

We conclude this section by noting that a sequence  $\langle T, G, y, p, d, s \rangle$  of related models of ACDT (Definition 6) will give rise to a sequence  $\langle T, G, p, d, s \rangle$  of  $d/s$ -models of SCDT, as soon as  $d' - s'$  satisfies the collective budget constraint (C.6) (Walras' axiom) for all price vectors. As already mentioned at the end of Section 7, we do not know whether all the relevant conditions can be satisfied together.

## 9. PLAUSIBLE CLAIMS OF IDT

In the same spirit as in Section 8 we will now formulate two possible empirical claims of IDT.  $D$  will generally refer to a finite set of individuals.



We start with a claim about (excess) demand as one might register by interviewing people.

DEFINITION 12.  $\langle T, D, G, e, d \rangle$  is a possible sequence of intended interview-applications of IDT iff

- (1)  $e: T \times D \times G \rightarrow \mathbb{R}_0^+$  ("initial" endowment)
- (2)  $d: T \times D \times G \times (\mathbb{R}_0^+)^n \rightarrow \mathbb{R}$  (stated excess demand)
- (3) for all  $t, i, j$  and  $q: e_{ij}^t + d_{ij}^t(q) \geq 0$  (commodity constraint)
- (4) for all  $t, i$  and  $q: \sum_j q_j d_{ij}^t(q) = 0$  (budget constraint)
- (5) for all  $t, j$  and  $q: \sum_i d_{ij}^t(q) = 0$  (cleared markets)

DEFINITION 13.  $\langle T, D, G, e, u \rangle$  is a sequence of related models of IDT' iff

- (1)  $e: T \times D \times G \rightarrow \mathbb{R}_0^+$  (initial endowment)
- (2)  $u: D \times (\mathbb{R}_0^+)^n \rightarrow \mathbb{R}$  (time-invariant(!) utility)
- (3)  $\langle D, G, e', u \rangle \in \text{IDT}'$  (restricted models of IDT)  
(i.e., (I.1, 2, 3, 4, 8))

DEFINITION 14.  $\langle T, D, G, e, u, d \rangle$  is a sequence of related model of IDT iff

- (1)  $e$  as in Definition 13.1
- (2)  $u$  as in Definition 13.2
- (3)  $d: T \times D \times G \times (\mathbb{R}_0^+)^n \rightarrow \mathbb{R}$  (utility maximizing individual excess demand)
- (4)  $\langle D, G, e', u, d' \rangle \in \text{IDT}$  (models of IDT)  
(i.e., + (I.5, 6, 7, 9))

Theorem 1 implies that a sequence  $\langle T, D, G, e, u \rangle$  satisfying Definition 13 generates a unique sequence  $\langle T, D, G, e, u, d_* \rangle$  satisfying Definition 14. This will be used in the claim of IDT with respect to an actual sequence of interview-applications: the stated excess demand is the utility maximizing individual excess demand generated by some sequence of restricted models based on a time-invariant utility function. Formally:

DEFINITION 15. Empirical claim of IDT with respect to an actual sequence of intended interview-applications of IDT  $\langle T, D, G, e, d \rangle$ :

there is a utility function  $u$  such that  $\langle T, D, G, e, u \rangle$  is a sequence of related models of IDT' such that the (according to Theorem 1) generated unique sequence of related models of IDT  $\langle T, D, G, e, u, d_* \rangle$  such that for all  $t$

$$d^t = d_*^t$$

For analogous considerations about determination as in Section 8, assuming Definition 15,  $e$  and  $d$  are treated as non-theoretical with respect to IDT, and  $u$  and  $d_*$  are theoretical, and  $u$  is even more theoretical than  $d_*$ . Note that the situation is more complicated if we realize the fact that  $d$  can only be obtained by extra- and interpolation of finite 'interview-data'. However, the epistemic hierarchy of functions does not seem to be affected by this. Note too that there is no inconsistency between asserting that  $d$  and  $s$  are *treated* as theoretical functions with respect to ACDT and SCDT and, at the same time, asserting that  $d$  is *treated* as non-theoretical with respect to interview applications of IDT. We do not discuss whether  $d$  is (an 'ontological is') a theoretical function or not.

A second theoretically possible empirical claim of IDT constitutes the individual counterpart of the "exchange-claim" of CDT formulated in Section 8.

**DEFINITION 16.**  $\langle T, D, G, e, p, g \rangle$  is a possible sequence of intended exchange-applications of IDT iff

- (1)  $e: T \times D \times G \rightarrow \mathbb{R}_0^+$  (initial endowment)
- (2)  $p: T \times G \rightarrow \mathbb{R}_0^+$  (exchange prices)
- (3)  $g: T \times D \times G \rightarrow \mathbb{R}$  (exchanged amounts)
- (4) for all  $t, i, j: e_{ij}^t + g_{ij}^t \geq 0$  (commodity constraint)
- (5) for all  $t, i: \sum_j p_j^t g_{ij}^t = 0$  (budget constraint)
- (6) for all  $t, j: \sum_i g_{ij}^t = 0$  (cleared markets)

Now the claim of IDT with respect to an actual sequence of exchange applications reads of course: the exchanged amounts correspond to the utility maximizing individual excess demand at the exchange prices generated by some sequence of restricted models based on a time-invariant utility function. Formally:

**DEFINITION 17.** Empirical claim of IDT with respect to an actual

sequence of intended *exchange*-applications of IDT  $\langle T, D, G, e, p, g \rangle$ :

there is a utility function  $u$  such that  $\langle T, D, G, e, u \rangle$  is a sequence of related models of IDT' such that the (according to Theorem 1) generated unique sequence of related models of IDT  $\langle T, D, G, e, u, d_* \rangle$  is such that

$$g' = d_*^i(p')$$

Note that this is a rather strong claim: it asserts, among other things, that actual prices are equilibrium prices, in the sense that at the actual prices all individuals are able to fulfil their desired transactions (see also Section 10).

Plausible determination considerations lead now to the conclusion that, assuming Definition 17,  $e, p$  and  $g$  are non-theoretical with respect to IDT, that  $u$  and  $d_*$  are theoretical, and that  $d_*$ , though not fully determined by  $g'$ , is nevertheless less theoretical than  $u$ , for the latter determines the former (according to Theorem 1) whereas the converse does not hold.

It is interesting to remark that Definitions 15 and 17 can be combined. The combined claim asserts that there is a utility function with corresponding demand function  $d_*$  such that  $g' = d_*^i = d'$ . However, this combined claim leads to inconsistencies when  $g' \neq d'$ , i.e., when agents do not respond honestly to questionnaires. The uncertainty with respect to the reliability of questionnaires is precisely the reason why economists hesitate to treat  $d$  at the collective level (see ACDT) as a non-theoretical term.

#### 10. MICRO-REDUCTION OF THE COLLECTIVE CLAIM

A plausible last question is the relation between the individual and collective exchange claims. Roughly speaking, one, in particular a theoretical economist, may and will expect that the individual claim implies the collective claim. We will formulate the precise implication for SCDT.

On the individual level we can also formulate *special* models of IDT (SIDT), i.e., models of IDT of which the individual excess demand function satisfies:

$$(I.10) \quad \textit{substitutability: for all } i, j, q \text{ and } k \neq j, \partial d_{ij}(q)/\partial q_k > 0.$$

By a trick we bypass the question of a sufficient condition on restricted models of IDT guaranteeing substitutability for the (according to Theorem 1) generated unique model. We just define *restricted special models of IDT*,  $SIDT'$ , implicitly as those restricted models which generate special models. Finally, the definition of the *empirical claim of  $SIDT$*  results of course from replacing in Definition 17 IDT by  $SIDT$  and  $IDT'$  by  $SIDT'$ .

Later it will be used that Theorem 4 can be reformulated with an intermediate stage: a model of IDT generates a *restricted  $d/s$ -model of CDT*, by first aggregating the positive individual demands separately from the non-positive individual demands, i.e., the positive individual supplies. Here a restricted  $d/s$ -model is of course by definition such that  $z =_{df} d - s$  generates a restricted model of CDT. It is now also easy to check that Theorem 4 can be strengthened to the statement that a *special model of IDT* generates (a restricted  $d/s$ -model of CDT that generates) a restricted *special model of CDT*, i.e., a restricted model of CDT, satisfying gross substitutability (C.8).

To formulate the collective claim implied by the empirical claim of  $SIDT$  it is finally necessary to note that a possible sequence  $\langle T, D, G, e, p, g \rangle$  of intended exchange-applications of IDT (Definition 16), hence of  $SIDT$ , generates a unique possible sequence  $\langle T, G, p, f \rangle$  of intended applications of SCDT (Definition 8) by equating  $f$  with the sum of the positive exchanged amounts (i.e., the amounts bought by individuals). Note that this sum is, due to the assumed cleared markets, equal to the sum of the sold amounts.

Now the following theorem is not difficult to prove on the basis of the informal definitions, the elaboration of Theorem 4 and Definitions 8 and 16.

**THEOREM 6.** The empirical claim of  $SIDT$  with respect to an actual sequence of intended exchange-applications of  $SIDT$  implies the empirical claim of SCDT with respect to the generated sequence of intended applications of SCDT.

It is tempting to make the following terminological remark. Theorem 6 states that a certain collective claim can be deductively derived from a claim made by an individualistic (or micro-) theory. According to a recent diagnosis of terms used in philosophy of science (Kuipers, 1987) this cannot only generally be called a deductive

explanation of a collective claim, due to the apparent occurrence of an application step of a micro-theory and an aggregation step, and the absence of a transformation and an approximation step, it should more precisely be called: a deductive homogeneous micro-reduction of the collective claim.

Besides the remarks on the reduction of the collective claim to the individual claim we have to pay attention to the reversed relation, because – as is already mentioned – the individual exchange claim is theoretically possible, but not often encountered in economic analysis (see below). Economists treat the individual and the collective claim as equivalent: not only is the collective claim implied by the individual claim (as the foregoing remarks on micro-reduction make clear), but the individual claim is also seen to be implied by the collective claim. This last implication hinges on two plausible (and often made) assumptions: (i) the “principle of voluntary exchange”, which says that individuals cannot be enforced to trade more than they like to and (ii) the “principle of perfect markets”, sometimes referred to as the “short-rule”, which says that there cannot be unsatisfied demand and supply on the same market. (See Janssen (1987) for the use macro-economic theories make of these principles in interpreting economic statistics.)

In line with these remarks economists actually adhere to a sophisticated version of the individual claim. Instead of claiming that all individuals are able to carry out their most preferred actions (see Definition 17), one should interpret the individual claim economists are adhering to as a conditional one: if there is a market excess demand (supply), then all potential sellers (buyers) are able to get what they supply (demand). (Remark that this is another way to state the “principle of perfect markets”.) It is clear that the collective claim cannot be reduced to this sophisticated version of the individual claim. As this sophisticated individual claim is more in line with the way economists interpret their theories we doubt whether present economic theories can be seen as elements of a reductive research programme as is commonly alleged.

## 11. FINAL REMARKS

Although the “definition-density” in this paper, in particular in the last sections, is indeed very high, we believe to have provided more insight

in the structure of GET and in the possibilities to make empirical claims with GET.

The present analysis raises many new questions, some within the present account of GET without production, others crossing this boundary. Of course, the main question of the latter type is how the present analysis can be extended to include production. We hope and we believe that the structuralist start made by Hamminga and Balzer (1986) can be adapted in a direction which is more in line with the present stratified approach of demand theory. But this can only be the subject of a new paper.

#### NOTES

\* The authors would like to thank F. Haslinger for his constructive criticism.

<sup>1</sup> Although there may be peculiar interpretations of GET for which this axiom does not hold, it is a conceptual requisite in order to be able to talk about utility maximization, because the utility function is defined only for nonnegative amounts of goods. It is for this reason that it is included in the definition.

<sup>2</sup> If there is at least one individual who is non-satiated at every consumption bundle, then all goods which can be obtained at zero prices are in excess demand. In this case the equilibrium axiom amounts to saying that demand and supply balance on all markets. Thus, the case between brackets is exceptional.

<sup>3</sup> "d" should not be confused with the individual excess demand function in Definition 1.1.

#### REFERENCES

- Arrow, K. J.: 1968, 'Economic Equilibrium', *International Encyclopedia of the Social Sciences*, MacMillan and Free Press, pp. 376-89.
- Arrow, K. J. and L. Hurwicz: 1960, 'Competitive Stability and Weak Gross Substitutability', *International Economic Review* 1, 38-49.
- Balzer, W.: 1982, 'A Logical Reconstruction of Pure Exchange Economics', *Erkenntnis* 17, 23-46.
- Balzer, W.: 1985, 'The Proper Reconstruction of Exchange Economics', *Erkenntnis* 23, 185-200.
- Debreu, G.: 1974, 'Excess Demand Functions', *J. of Mathematical Economics* 1, 15-21.
- Hamminga, B.: 1982, 'Neoclassical Theory Structure and Theory Development: The Ohlin Samuelson Programme in the Theory of International Trade' in W. Stegmüller et al. (eds.), *Philosophy of Economics*, Springer, Berlin, pp. 1-16.
- Hamminga, B.: 1983, *Neoclassical Theory Structure and Theory Development*, Springer, Berlin.
- Hamminga, B. and W. Balzer: 1986, 'The Basic Structure of Neoclassical General Equilibrium Theory', *Erkenntnis* 25, 31-46.

- Händler, E.: 1980, 'The Logical Structure of Modern Neoclassical Static Micro-economic Equilibrium Theory', *Erkenntnis* **15**, 33–53.
- Hands, D.: 1985a, 'The Logical Reconstruction of Pure Exchange Economics: Another Alternative', *Theory and Decision*, 259–78.
- Hands, D.: 1985b, 'The Structuralist View of Economic Theories: A Review Essay', *Economics and Philosophy* **1**, 303–35.
- Haslinger, F.: 1983, 'A Logical Reconstruction of Pure Exchange Economics: An Alternative View', *Erkenntnis* **18**, 115–29.
- Janssen, M.: 1987, 'Structuralist Reconstructions of Classical and Keynesian Macroeconomics', this volume.
- Kuipers, T.: 1982, 'Approaching Descriptive and Theoretical Truth', *Erkenntnis* **18**, 343–378.
- Kuipers, T.: 1987, 'A Decomposition Model for Explanation and Reduction', Abstract-LMPS-VIII, Section 6, Volume 4, Moscow, 1987, 328–37.
- Sonnenschein, H.: 1972, 'Market Excess Demand Functions', *Econometrica* **40**, 549–63.
- Wald, A.: 1936, 'Über einige Gleichungssysteme der Mathematischen Ökonomie', *Zeitschrift für Nationalökonomie*, 637–70.

Manuscript received 25 January 1988

University of Groningen  
Department of Economics  
P.O. Box 800  
NL-9700 AV Groningen  
The Netherlands

University of Groningen  
Department of Philosophy  
Westersingel 19  
NL-9718 CL Groningen  
The Netherlands