

## COMPARISON OF DC MOTOR SPEED CONTROL PERFORMANCE USING FUZZY LOGIC AND MODEL PREDICTIVE CONTROL METHOD

Mustefa Jibril<sup>\*1</sup>, Messay Tadese<sup>\*2</sup>, Eliyas Alemayehu Tadese<sup>\*3</sup>

<sup>\*1,2</sup>Msc, School of Electrical & Computer Engineering, Dire Dawa Institute of Technology, Dire Dawa, Ethiopia

<sup>\*3</sup>Msc, Faculty of Electrical & Computer Engineering, Jimma Institute of Technology, Jimma, Ethiopia

### ABSTRACT

The main target of this paper is to control the speed of DC motor by comparing the actual and the desired speed set point. The DC motor is designed using Fuzzy logic and MPC controllers. The comparison is made between the proposed controllers for the control target speed of the DC motor using square and white noise desired input signals with the help of Matlab/Simulink software. It has been realized that the design based on the fuzzy logic controller track the set point with the best steady state and transient system behavior than the design with MPC controller. Finally, the comparative simulation result prove the effectiveness of the DC motor with fuzzy logic controller.

**Keywords:** DC Motor, Fuzzy Logic Controller, MPC Controller

### I. INTRODUCTION

A DC motor is any of a class of rotary electrical machine that converts direct current electrical power into mechanical energy. The maximum not unusual sorts rely on the forces produced by means of magnetic fields. Nearly all forms of DC motors have a few internal mechanism, both electromechanical and digital, to periodically change the path of modern-day in part of the motor.

DC motors had been the primary form of motor extensively used, as they might be powered from existing direct-modern lights energy distribution structures. A DC motor's pace may be controlled over an extensive variety, the usage of either a variable deliver voltage or by means of changing the power of current in its electrical windings. Small DC machines are used in gear, toys, and appliances. The established motor can function on direct modern however is a lightweight brushed motor used for transportable energy equipment and appliances. Larger DC motors are currently used in electrical motors, elevator and hoists, and in drives for metal rolling generators.

#### 1. Mathematical model of a DC motor

The torque of the motor is directly proportional to the current and it is described as

$$\tau = K_a i \quad (1)$$

Where

$K_a$  Armature constant

The electromotive force,  $V_{em}$ , is directly proportional to the angular speed of the motor,

$$V_{em} = K_{em} \omega \quad (2)$$

Where

$K_{em}$  Emf constant

By using Newton's laws, the mechanical system of the motor equations is derived as:

$$J \frac{d\omega}{dt} = -K_f \omega + K_a i \quad (3)$$

Where,

$K_f \omega$  Approximation for viscous friction.

The electrical system of the motor equations can be described by

$$\frac{di}{dt} = -\frac{R}{L}i - \frac{K_{em}}{L}\omega + \frac{1}{L}V_{app} \quad (4)$$

By using Laplace transform and substituting the value of  $i(s)$ , we will get the differential equation for input  $V_{app}(s)$  and the output is the speed of the motor  $\omega(s)$

$$\frac{\omega(s)}{V_{app}(s)} = \frac{K_a}{(Ls + R)(Js + K_f) + K_a K_{em}} \quad (5)$$

The parameters of the Dc motor are shown in Table 1 below.

**Table 1:** Dc motor parameters

No	Parameters	Symbol	Value
1	Moment of inertia of the rotor	J	0.2 $kgm^2 / s^2$
2	Damping ratio of the mechanical system	$K_f$	0.4 Nms
3	Electromotive force constant	$K_a = K_{em}$	0.4 Nm/A
4	Electric resistance	R	8 $\Omega$
5	Electric inductance	L	1 H

The Dc motor transfer function is

$$\frac{\omega(s)}{V_{app}(s)} = \frac{0.4}{0.2s^2 + 2s + 4.8}$$

## 2. Proposed Controllers Design

In this section, the design of the proposed controllers will be discussed.

### 2.1 Fuzzy Logic Control

Fuzzy Logic Control (FLC) or Fuzzy Linguistic Control is a knowledge primarily based control strategy that can be used

- While both a sufficient correct and but no longer unreasonably complicated model of the plant is unavailable
- When a (single) specific degree of overall performance isn't significant or realistic.

FLC model design is based totally on empirically received knowledge concerning the operation of the process. This expertise, cast into linguistic, or rule-based form, is the main of the FLC system. The rule base (know-how base) gives nonlinear transformations with none built-in dynamics.

### 2.2 Input and Output of fuzzy controller

The error and change of error input and the output of the fuzzy logic controller is shown in Figure 1, Figure 2 and Figure 3 respectively.

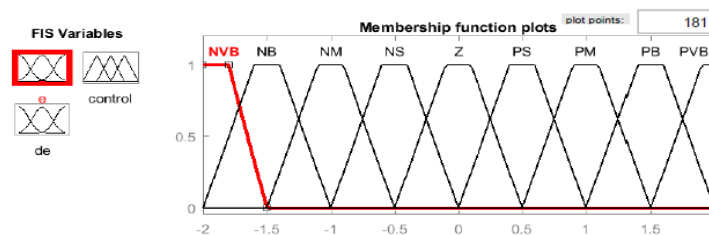

**Figure 1:** Error input

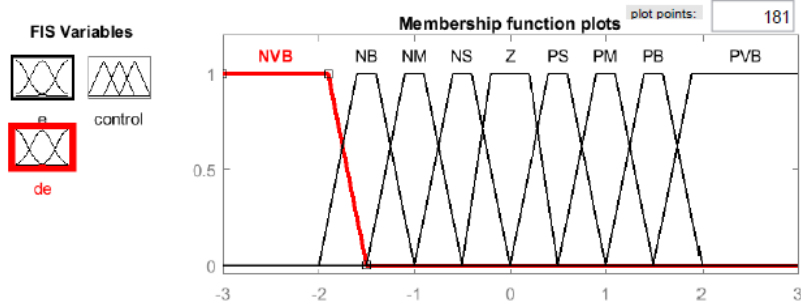

Figure 2: Change in error input

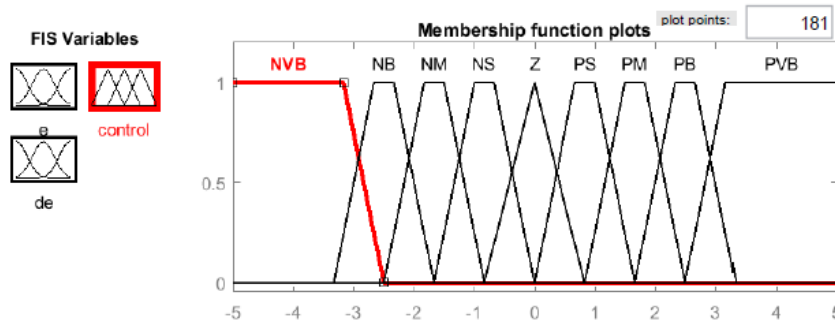

Figure 3: Output

### 2.3 MPC Control

The model-primarily based predictive control (MPC) technique is also referred to as the moving horizon control or the receding horizon control. The MPC is built using control and optimization tools. The objective of this write-up is to introduce the designer to the linear MPC which refers back to the circle of relatives of MPC schemes in which linear model of the managed objects are used in the control regulation synthesis.

A model predictive controller makes use of, at each sampling instant, the plant's present input and output measurements, the plant's contemporary state, and the plant's model to

- Calculate, over a finite horizon, a future control collection that optimizes a given performance index and satisfies constraints on the control action;
- Use the primary control in the sequence as the plant's input.

## II. RESULT AND DISCUSSION

Here in this section, the comparison of the Dc motor with the proposed controllers will be presented.

### 3.1 Comparison of Dc Motor with Fuzzy Logic and MPC Controllers for a Square Wave Input Signal

The Simulink model for the Dc motor with the proposed controllers for a square wave input reference speed (desired) is shown in Figure 4 below.

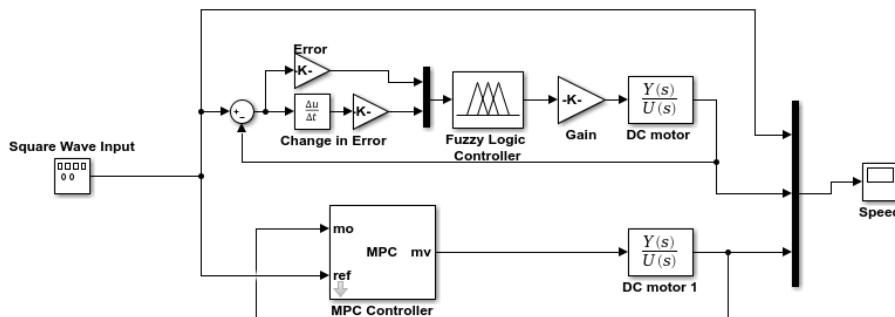
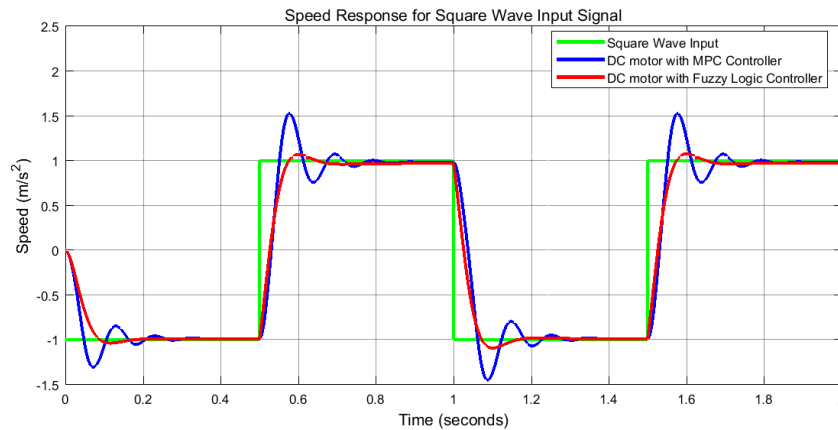

Figure 4: Simulink model for the Dc motor with the proposed controllers for a square wave input reference speed (desired)

The output response of the actual speed of the proposed controllers for a square wave input reference speed is shown in Figure 5 below.

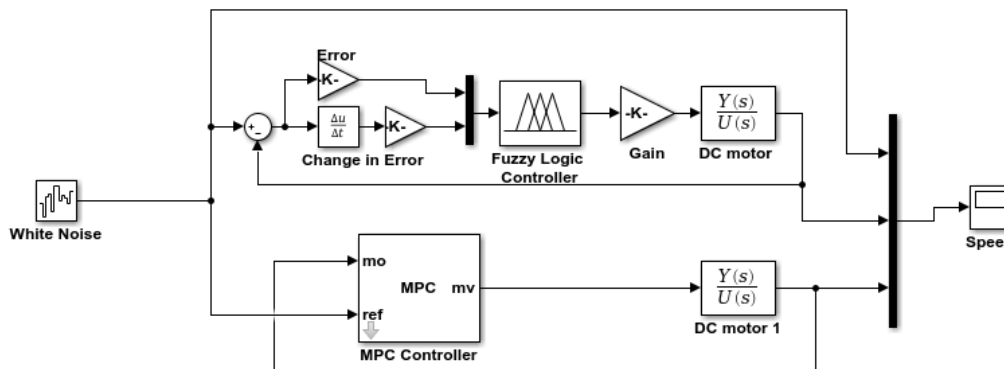

**Figure 5:** Output response of the actual speed of the proposed controllers for a square wave input reference speed

Figure 5 shows us that the Dc motor with MPC controller have higher overshoot and long settling time than the Dc motor with fuzzy logic controller.

### 3.2 Comparison of Dc Motor with Fuzzy Logic and MPC Controllers for a White Noise Input Signal

The Simulink model for the Dc motor with the proposed controllers for a white noise input reference speed (desired) is shown in Figure 6 below.



**Figure 6** Simulink model for the Dc motor with the proposed controllers for a white noise input reference speed (desired)

The output response of the actual speed of the proposed controllers for a white noise input reference speed is shown in Figure 7 below.

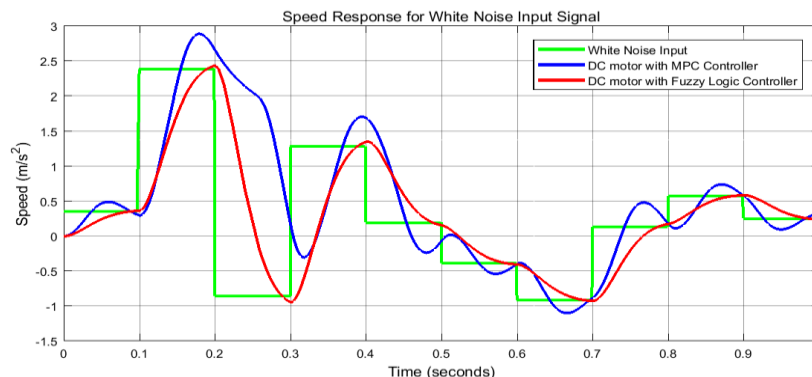

**Figure 7:** Output response of the actual speed of the proposed controllers for a white noise input reference speed

Figure 7 shows us that the Dc motor with MPC controller have higher overshoot and less time to track the operating speed than the Dc motor with fuzzy logic controller.

### III. CONCLUSION

The design of the DC motor with the proposed controllers has been done using Matlab/Simulink software successfully. The aim of this paper is to compare the DC motor speed tracking performance using fuzzy logic and model predictive control strategy. The simulation is done using square and white noise set point signals for the design of the DC motor with fuzzy logic and MPC controllers. The simulation result shows us that the Dc motor with MPC controller have higher overshoot and less time to track the operating speed and large settling time. Finally the DC motor with fuzzy logic controller shows better performance in tracking the set point signal with small overshoot.

### IV. REFERENCE

- [1] Messay Tadese et al. "Performance Investigation of Dc Motor Angular Velocity using Optimal and Robust Control Method" International Journal of Advance Research and Innovative Ideas in Education, Vol. 6, Issue. 2, pp. 1016-1022, 2020.
- [2] Panagiotis K. et al. "Fuzzy Q-Learning Agent for Online Tuning of PID Controller for DC Motor Speed Control" Algorithms for PID Controller (Special Issue), Vol. 11, Issue. 10, 2018.
- [3] Peicheng S. et al. "Design of Dual DC Motor Control System Based on DSP" Journal of Physics: Conference Series, Vol. 887, The 2<sup>nd</sup> Annual International Conference on Information System and artificial Intelligence (ISAI2017) 14-16, 2017.
- [4] Thang N et al. "The Control Structure for DC Motor Based on the Flatness Control" International Journal of Power Electronics and Drive Systems, Vol. 8, Issue.4, pp. 1814-1821, 2017.
- [5] Someshwar Dutt Pathak et al. "A Comparative Study of DC Motor for Optimal Performance Using LAG Compensator and PID Controller Implemented by MATLAB" International Journal of Advanced Research in Computer and Communication Engineering, Vol. 5, Issue 5, pp. 278-283, May 2016.