

# Does an Embedded Wind Turbine Reduce a Company's Electricity Bill? Case Study of a 300 kW Wind Turbine in Ireland

Tony Kealy<sup>1</sup> 

Received: 25 March 2015 / Accepted: 24 August 2015 / Published online: 2 September 2015  
© The Author(s) 2015. This article is published with open access at Springerlink.com

**Abstract** In recent years, a growing number of small-to-medium-enterprises are embracing wind turbine projects not only as part of their cost reduction strategy but also to actively play their part in the global fight against climate change. However, it would appear there are currently limited empirical studies carried out in this emerging industry. This case study analyses the cost effectiveness of one such wind turbine initiative by a company in the Republic of Ireland, who invested in a 300 kW embedded wind turbine project at the end of 2013. The research methodology which is primarily a case study analysis included comparing historical electricity utility bills which allowed the 2013 quantity of electrical energy units imported, i.e. the year before the turbine was installed to be compared with the 2014 value, i.e. the year after the turbine was installed. Numerous site visits were undertaken over a four-year period, during which electric meter readings were recorded and stored. The findings of this piece of research indicate that the installation of the embedded wind turbine had minimal positive effect on the annual electricity costs for the company. Indeed the turbine appears to have significant negative effects such as a need for an increased maximum import capacity and also it appeared to contribute to a deteriorating utility power factor. While the aesthetic nature of the on-site turbine seemed to create a positive image of the company, it would appear that caution should be exercised when business owners select alternative energy providers who claim to be experts in the energy field but may have limited knowledge in this area of

wind energy, which as of yet has minimal robust research into all aspects of its benefits/attributes.

**Keywords** Embedded generation · Wind turbine · Corporate social responsibility · Business ethics · Sustainable development

## Introduction

The relentless push for business growth as part of our capitalist economic culture has put pressure on natural and human resources. The supply of oil, coal, and gas would appear to be approaching the end period of their life cycle (Shafiee and Topal 2009). In addition to this, it is argued by many scientists that the burning of fossil fuels in power generating plants is contributing to environmental degradation, which over time could jeopardise our wealth and even our existence (Catalin and Nicoleta 2011). This fragile relationship between the economy and the environment has been largely ignored up to now, as business growth and shareholder profits took precedence over the natural environment. In more recent times, research papers, reports and international conferences such as Kyoto (1997), Doha (2012) and Rio (2012) have drawn attention to an imminent environmental, economical and human crisis. From these studies, a new model of business management has emerged, namely sustainable development which would appear to link the economic, environmental and human spheres. The wind energy industry grew out of this shift in business thinking, as wind turbines were seen as an environmentally friendly alternative to fossil-fuel burning plants for power generation. This research investigates in detail one such wind energy project undertaken by a small-to-medium-enterprise (SME) based in rural Ireland.

---

✉ Tony Kealy  
tony.kealy@dit.ie

<sup>1</sup> Department of Electrical Services Engineering, Dublin Institute of Technology, Dublin, Ireland

## Literature Review

### Sustainable Development

The somewhat recent phenomenon of globalisation has helped to create interconnectivity and interdependence between people, businesses, cultures and nations as never before. This phenomenon has introduced a new kind of responsibility where terms like corporate social responsibility (CSR), corporate responsibility (CR) and corporate citizenship (CC) have emerged (Aspling 2013, p. 46). Corporations surely wish to see a developed society so that society will continue to be their paying customers. It is in this context that the concept of sustainable business development has emerged as an alternative philosophy to the widely used growth-driven and profit-driven, neoclassical economic theory which has put enormous pressure on our vast but finite natural resources, causing environmental degradation which has the potential to threaten our wealth and even our existence (Catalin and Nicoleta 2011). Sustainable development theory is based on the triple-bottom-line approach of the three *P*'s (Elkington 1997) namely *Profit*, *People*, and *Planet*, instead of the more narrow-focused growth-driven and profit-driven model. Indeed Kealy (2014b) claimed that the three *P*'s are interconnected and interdependent on each other. Of the aforementioned 'three *P*'s', the most quoted element in the media currently and in public discourse is the *Planet* component. A major driver in this global consciousness has been the alleged negative effect that human activity is having on our planet namely advancing the phenomenon of global warming, which scientists claim is partly due to our obsessive use of fossil-fuelled energy sources. Research by Besio and Pronzini (2014) claims that corporations have a moral obligation in how they respond to societal demands to take responsibility for climate change. They argue that in some occurrences, morality in business becomes a mere façade while in others it serves as a decision-making criterion and deeply influences the core activities in firms. Brusseau et al. (2013) also highlights concerns regarding the authenticity of some company's adoption of green energy strategies. They argue that many businesses are "green-washing", a process of appearing to embrace social and environmental stewardship within the business model, while the real intention is in fact to convert that branded concern into money on the *Profit* bottom line.

### Renewable Energy

Sustainable business development would appear to encompass all three elements of CR namely people, profit and planet. Kealy (2014b) argues that these components are

inextricably linked, but many businesses today may perceive that a better use of energy sources is primarily the most appropriate way to comply with CSR guidelines (Kealy 2014b). In relation to better energy usage, it is generally accepted that there are two ways to influence this process. *Demand-side* management (DSM): use less energy in the factory to do the same job, and/or *Supply-side* management (SSM): seek to implement alternative natural energy sources. While the Irish government is keen to promote both initiatives as a means to decarbonise its energy system, currently there appears to be more activity in the planning and building of alternative energy sources like wind turbines, with a major push for wind penetration to increase as part of these incentives. This wind turbine activity is not without opposition, as some people have begun to question the benefits of wind energy. Some also argue that turbines cause damage to our environment and have the potential to divide local communities forced to live in industrial landscapes. The Sustainable Energy Authority of Ireland (SEAI), in its recent report 'Quantifying Ireland's Fuel and CO<sub>2</sub> Emissions Savings from Renewable Electricity in 2012' stated that while the overall net CO<sub>2</sub> emissions intensity of the electricity system improves by 15 %, the following points also need to be stated:

- With renewable electricity on the system, fossil-fuel generators spend less time generating for each time they start (additional cycling).
- Displacement by renewable electricity generation reduces the average output from fossil-fuel generators, indicated by a reduction in the on-line capacity factor of combined cycle gas turbine (CCGT) and coal-fired generators.
- Individual fossil-fuel generators run in less efficient modes with renewable electricity on the system, showing a 7 % increase in the CO<sub>2</sub> emissions intensity for such generators.

The variation and uncertainty in the output of wind farms present challenges to the national electricity system operator. The system operator must decide ahead of time what generators should be on-line to meet the load demand in an efficient way. This decision is based on forecasts of wind output and electricity demand, which may be unpredictable. The variations are normally managed by providing fossil-fuel generators as *spinning reserve* in waiting mode, ready to take over if and when the wind turbine output drops. Some fossil-fuel turbines need to be *spinning* as they can take several hours to warm up and come on-line. This is why the additional cycling and ramping and reductions in on-line capacity factors due to wind generation reduce the efficiency and effectiveness of individual fossil-fuel generators (SEAI 2012).

## Sustainability Reporting

The SME on which this research is based is actively committed to the sustainability ethos in its host country Ireland. It is aligned to the 'Origin Green' sustainability reporting framework from Bord Bia (2015). This Origin Green sustainability plan covers in detail the following areas:

- Raw Material Sourcing
- Energy Usage and Reduction
- Water Conservation Using Rainwater Harvesting
- Waste Product
- Biodiversity
- Social Sustainability

However, it is argued by Milne and Gray (2013) that sustainability reporting by itself does not contribute to the sustaining of the Earth's ecology. They claim that many organisations use the fact that they are reporting in the first instance, to carry on as normal without making any significant changes to their business practices, which paradoxically may lead to greater levels of *un*-sustainability. In order to improve the validity, or otherwise, of sustainability reports, Van Der Ploeg and Vanclay (2013) propose a sustainability reporting assessment 10-question checklist as a functional tool for use by stakeholders to evaluate the content of their sustainability reporting. Among the issues addressed by the questionnaire were (i) use of evidence to support claims and (ii) documented impacts of all stakeholders, including vulnerable groups and negatively affected groups. The authors use the internationally established global reporting initiative (GRI) in its testing of the effectiveness of the checklist on an authentic but anonymous company.

## Energy Policy

Ireland is committed to reducing its dependence on fossil fuels in line with European Union directives (Department of Communications, Energy and Natural Resources, DCENR 2015). The Irish government has initiated a policy whereby 40 % of its electricity is intended to be generated by renewable sources by the year 2020 (SEAI 2013). Of this figure, it is envisaged that a significant portion will come from wind energy which has prompted increased interest in wind farm development. If this wind energy plan materialises, Ireland will become one of the world's largest power-from-wind producers as a percentage of total supply. As part of Ireland's deregulated single electricity market (SEM), private wind developers can construct and provide power to their local power system. However, it would appear that caution needs to be applied when predictions are made with regard to potential energy output

from these machines which are in their infancy stage in the overall life cycle of the product.

## Wind Turbines

This author noted that there appears to be a significant shortage of empirical research in the literature which evaluates wind turbine performance based on data obtained from actual wind turbines installations, although there is a plethora of research modelling *estimated* values. One such estimated wind energy potential was investigated using locally accessed wind data for a potential site in Konya, Turkey. The one-year wind data were statistically analysed using computer software. A predicted simple payback period of 6.44 years for a 6 MW wind farm was calculated by Kose et al. (2014). It was envisaged by the researchers that this payback period would attract local investors to invest in wind energy technology. It should be noted that this was not a definitive payback period but a predicted one. In terms of actual data, an empirical study by Kealy (2014a) investigated the financial performance of a 10 kW rated small-scale embedded wind turbine installation in Ireland over the period from 2010 to 2013. The project had a capital cost of €26,620 and the turbine produces 7260 kWh units of energy per annum. This gave a capacity factor of a meagre 8.3 %. Considering that the client had an annual energy usage of approximately 76,338 kWh's, the investment did not have a significant impact in his imported electricity usage and the results appear disappointing. The payback period of this investment was approximately 23 years, significantly almost four times greater than the Kose et al.'s (2014) predicted value. The capacity factor in the research by Kealy (2014a) is extremely low at 8.3 %, and this is confirmed by Henaghan (2013) who analysed capacity factor data from 77 wind farms in both the Republic of Ireland and Northern Ireland in the period 2008–2012. Of the wind farms surveyed, the highest recorded capacity factor (CF) was 38.48 %, the lowest CF was 19.36 % and the average CF was 27.9 %. These data were extrapolated from a single electricity market operator (SEMO) source. It appears clear from the aforementioned literature that the performance of wind turbines can be varied and ultimately depends upon many factors. International Standard IEC 61400-12-1 (*Wind Turbines—Part 12-1: Power performance measurements of electricity producing wind turbines*) does provide a uniform methodology which should ensure that the measurement and analysis of turbine power performance is consistent, accurate and reproducible. However, caution is advised when using the standard due to the differences that can arise from large variations in wind shear and turbulence. The wind turbine power performance characteristics are determined by the measured power curve and the

estimated annual energy production. However, a significant shortage of published empirical research studies into wind energy projects for SME's has been identified in the literature. Private wind energy developers would be expected to have relevant data but this is not generally available to the public as it may be deemed commercially sensitive data. It is clear that for an SME, deciding on a wind turbine investment for the company is indeed a significant undertaking due to the lack of empirical data with which to assist in the making of such a decision, hence the need for this independent study.

### Literature Review Conclusion

It appears that the literature is sparse on empirical data in relation to individual wind turbine projects. Certainly there are much data and research on renewable energy and its theoretical benefits highlighted. However, singular embedded wind energy projects have yet to be investigated thoroughly, and the significant positive rhetoric and hearsay that surround such projects remains to be challenged by empirical investigation. This research seeks to contribute to this process.

### Research Site

This research was conducted on an SME situated in rural Ireland in the North-East of the country. The company is one of the largest growers, packers, and distributors of fresh produce to the retail market. The full-time workforce is 200 people and has grown steadily since its inception in 1982. The company embraced supply-side management at the end of 2013 by installing an embedded 300 kW on-site wind turbine, Fig. 1. The company has an approximate annual electrical energy usage of 1,200,000 kWh units (2013 values) and has targeted a reduction of this value as a means to reduce their carbon footprint as recommended in the sustainability reporting guidelines. An embedded wind turbine was seen as a strategic initiative in helping to reach these energy reduction targets. To this end, a 300 kW on-site wind turbine was purchased and installed towards the end of 2013. This study particularly concentrates on the quantity of imported electrical energy units in the year before the turbine installation, i.e. 2013, and compares that value with the quantity of imported electrical energy units after installation, i.e. 2014, and also provides an opportunity for the intensive analysis of many specific details of embedded generation. As well as investing in the turbine installation, the company has also outsourced their energy management function to an Irish-owned external energy management company who specialises in supplying natural gas and electricity to the industrial and commercial market.



**Fig. 1** Picture of 300 kW DFIG on-site turbine

Embedded generation is an approach that employs small-scale technologies, like wind turbines, to produce electrical energy close to where the company is using the energy, thereby reducing transmission losses. In this case, the turbine is installed on the company site and is connected in parallel with the electric utility supply at the electrical intake in the main switch-room as shown in the diagram in Fig. 2. The marketers of embedded generators claim that they offer a number of potential benefits over traditional power generators, among which are lower-cost electricity, higher power reliability and security, and adverse environmental consequences are minimised. Cost-benefit analysis is often used in engineering where an effort is made to translate negative and positive utilities into monetary terms. However, in the case of this *new* wind energy technology, cost-benefit analysis is sometimes referred to as risk-benefit analysis because much of the analysis requires *estimating* the probability of certain benefits and costs.

The renewable energy solutions company who supplied the turbine is based in the South-East of Ireland. Access to the turbine tower is via a secure door at its base, accessible only to suitably qualified personnel. The turbine control panel and accessories are all located at the base of this tower. A digital controller indicates parameters used in the

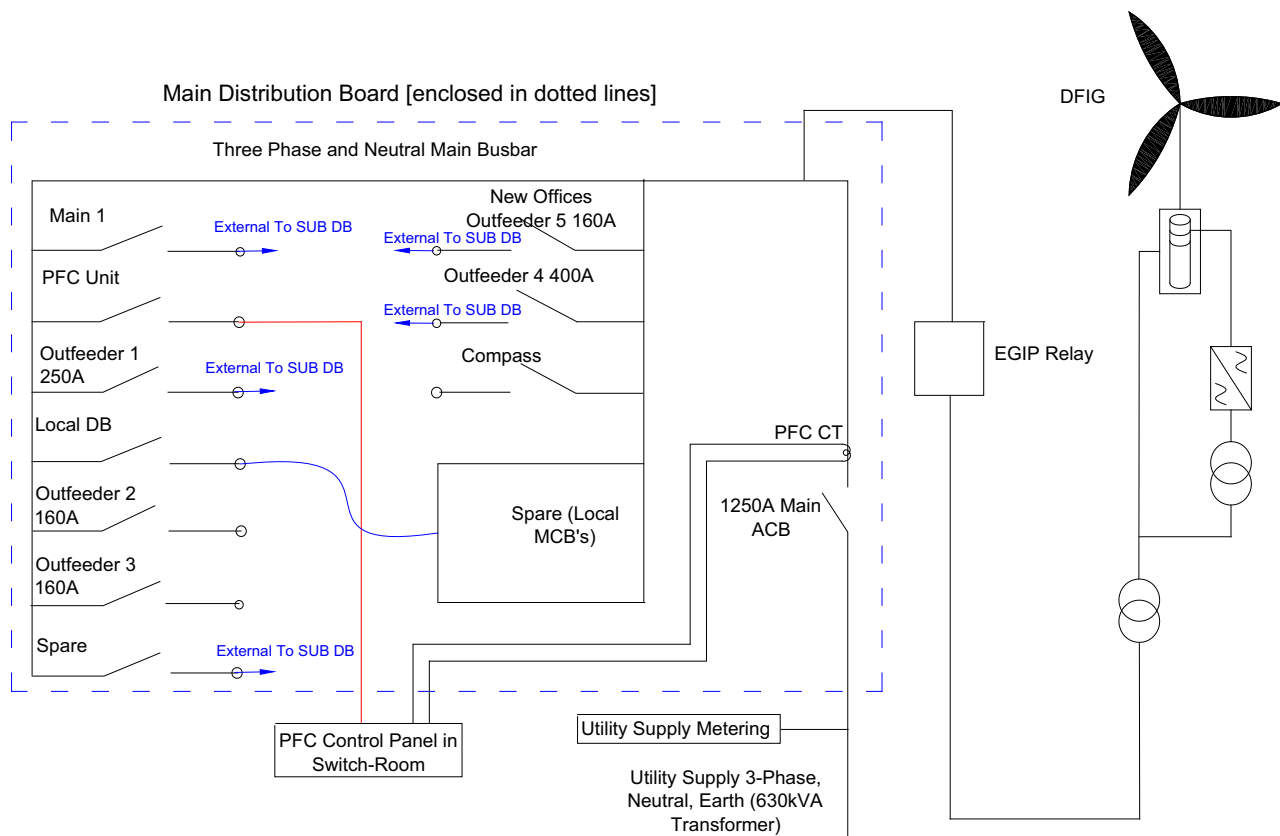

**Fig. 2** Electrical main distribution board in main switch-room and embedded turbine

analysis of this research, which include energy output data, alarm indication data, rotor speed data, and blade speed data. On each site visit, these parameters were noted and recorded.

The three-blade 300 kW double-fed induction generator (DFIG) turbine (Fig. 1) has a rotor diameter of 28 m. It is an asynchronous-type generator with a three-phase 690 V voltage output. An asynchronous (induction) generator is a type of alternating current (AC) generator that uses the principles of induction machines to produce power. Asynchronous generators work on the principle that when the rotor blades are rotating faster than the synchronous speed of the wind turbine, the machine is operating in generator mode and produces electrical power. If the rotor blades rotate slower than the synchronous speed of the wind turbine, the machine operates as a motor and draws current from the supply. A synchronous generator usually draws its excitation power from the National Grid (50 Hz in Ireland). The machine cannot start on its own as a generator; it starts as a motor. The DFIG speed-adjustable design uses an electronic controller to convert a variable frequency AC to direct current (DC) and back to AC at the grid frequency, i.e. 50 Hz. The AC/DC/AC conversion stage uses the Thyristor technology in this installation. A

thyristor is a solid-state semiconductor device that is used in turbine control as a switch. The thyristor technology has been in use since 1956, and while they can be used on large power switching, they have certain disadvantages and have virtually been replaced by other devices with superior switching characteristics, e.g. insulated-gate-bipolar-transistors (IGBT) devices. The rated wind speed is 13.5 m/s and the swept area is 615 m<sup>2</sup>. The hub height is 31 m.

The net cost of the project was €280,000 with an expected useful life of the turbine of 20 years. The wind turbine supplier predicted that the turbine installation would save 50 % of the overall electricity imported from the National Grid, i.e. the turbine would provide 600,000 kWh units of electricity per annum. They also predicted a pay-back period (PP) of 5 years. The distance between the wind turbine and the main electrical switch-room is 240 m. There are two cables in parallel between the turbine and the switch-room, and each cable is 4-core, 240 mm<sup>2</sup>, Steel-Wire-Armour (SWA), aluminium type. The business tariff used is the maximum-demand low voltage quarter-hour type. Prior to the installation of the turbine, the maximum import capacity (MIC) was set at 320 kVA. The 'utility supply metering' arrangement (Fig. 2) contains an import/export facility whereby any

units of energy produced by the turbine and not instantaneously required on-site can be exported back to the National Grid for a kWh unit price agreed between the turbine owner and the electrical utility provider. A total of 6332 kWh units of electricity were exported in 2014. It is assumed that the remaining kWh units are used on-site.

## Methodology

### Case Study Approach

The aim of this paper is to present a longitudinal case study of a 300 kW embedded wind turbine utilising empirical data obtained over a 4-year period (2011–2014). The focus of the research was primarily comparing the electrical features (annual kWh import units, average utility power factor) in 2013; the year before the turbine was installed with the same features the following year, 2014, after the turbine was installed. The methodology chosen for this research was the case study approach. The researcher felt that this approach would explore this relatively new concept of a singular embedded wind energy system where uncertainty still surrounds the benefits of such a project to business (Gray 2009). This relatively new phenomenon of the adaptation of wind energy systems by single business entities has led to a plethora of new “energy companies” providing this service. However, the effectiveness of these projects in relation to cost savings for the companies who undertake such energy systems has yet to be proven. So this project was conducted using the Case Study approach in order to make an empirical enquiry that would investigate this contemporary phenomenon within the real-life context of a wind turbine system. The researcher’s background as a qualified electrician coupled with level 9 qualifications in Control Engineering and also Management and Marketing contributed to a detailed data collection and analysis of appropriate variables in this study.

The researcher felt that due to limited detailed figures/research being available on singular embedded wind turbine systems, a case study approach at the outset would provide a basis for further studies on this phenomenon. To this end, as much detail and information and records were gathered in order to ensure robustness of this case study (Yin 2003). The theoretical stance that was taken at the outset within this study by the researcher was one that seeks to evaluate this wind energy project, the research theoretical hypothesis being that the adaptation of this renewable energy system would benefit the company financially. In doing so, however, the researcher was cognisant of the fact that the findings of a singular project such as this might be interesting and phenomenal in itself, but

caution would need to be taken not to generalise the results to the larger population of other such projects.

### Data Collection

This study involved analysing the effectiveness of this wind turbine installation in reducing the cost of the electrical energy bill. From the outset, it was clear that singular source data collection, i.e. just looking at the bills, would not be sufficiently detailed to effect robust findings. It was therefore necessary to collect data from four sources over a period of four years 2011–2014. A particular focus was then concentrated on the values for 2013 against 2014 in order to make accurate claims. The data collection was painstaking and detailed, collected manually and recorded by pen and paper and then transcribed onto spreadsheet software. This demanded weekly visits to the installation for the years 2011–2014.

The four primary sources of measurement were as follows:

- *Utility Electrical Bills* Number of imported energy units (kWh) per monthly/yearly period Total bill cost per monthly/yearly period in Euro.
- *Turbine Energy Output* Data recorded in kWh from digital energy meters in the turbine tower on yearly basis.
- *Wind Data from Met Eireann* Wind speed measurements (in knots per second converted to meters per second) for the 4 year period 2011–2014 from three wind-recording sites local to the case study installation, namely Mullingar, Dunsany and Dublin Airport. Average daily and monthly wind speeds were recorded and any adverse weather noted. Data were then transcribed to Excel spread sheets and analysed.
- *Factory Production Output* Production output in tonnes per year for 2011–2014.

Data for this study were accessed during the numerous site visits by the researcher. Full access was given to the researcher by the participant company. This included access to the turbine tower and also the main electrical switch-room. All data were manually collected. During 2014, the wind turbine was switched and locked OFF for a period of 12 days. This was to allow essential maintenance and testing to be carried out on the wind turbine installation. Production at the factory remained at normal levels during this period. Daily imported kWh units from the National Grid were recorded during this OFF period. When the turbine was switched back ON, the daily imported kWh units from the National Grid were recorded for a corresponding 12 days. Both sets of readings corresponded to the same times and days within the 12-day test period. These interesting and unexpected results are reported in the

findings “[Energy Import Values with Turbine OFF/ON](#)” section.

### Data Analysis

Data analysis in the Case Study methodology can sometimes prove challenging (Yin 2003). In this piece of research, a primarily time series analytical approach to the data analysis was utilised. The initial theoretical stance that the turbine would contribute to reduction in energy costs for the company formed the basis for a time series analysis of the data. The vast quantity of data collected in this study for the period 2011–2014 was subsequently analysed, and patterns/relationships between the aforementioned four key variables were noted and recorded.

### Validity and Reliability

Validity and reliability is of particular importance in the Case Study approach in research because of the reliance on data generated from limited situations (Gray 2009). This indeed is the case also in this study which although detailed was confined to a singular alternative energy unit only. The researcher was conscious at the outset of the difficulties in ensuring a valid approach to this research subject, given that the generally accepted hypothesis in relation to wind and alternative energy sources was that they were to be embraced as environmentally friendly cost saving Green initiatives. The researcher therefore investigated and recorded all possible variables that were or were not impacting on the effectiveness of the turbine installation, and allowed the data collected and the results to speak for themselves.

Reliability was assured by the conscientious documentation of the data over a protracted period of time and a thorough structured investigation of major variables that may have affected this data. The field procedures were strictly adhered to on a weekly basis with easy access to the study site secured and assistance of relevant workers. As a qualified electrician/electronic engineer, the researcher complied with all the health and safety guidelines on the site. Contingency plans etc. were identified from the outset.

## Findings/Results

### Annual Energy Usage and Tonnage Output

The annual factory tonnage output and imported energy kWh input for the 4-year period are shown in Table 1. The fourth column indicates the kWh/Tonne benchmark used to

**Table 1** Product output/kWh import

Year	Tonnes output	kWh import	kWh/tonne
2011	44,301	723,160	16.32
2012	46,157	921,578	19.97
2013	61,723	1,226,945	19.87
2014	69,437	1,377,185	19.83

calculate the number of electrical energy units used in kWh's to produce one tonne of product.

The figures shown in Table 1 indicate an increase in production in the four-year period between 2011 and 2014 with a corresponding increase in the number of electrical energy kWh units imported from the National Grid, exact values indicated in Table 2. The company paid a total of €206,310 for imported electrical energy in 2013. They paid a total of €225,497 for importing electrical energy in 2014, a 9.3 % increase on 2013 figures. The ‘*Origin Green*’ sustainability plan outlines baseline and target data as a means to monitor whether the improvements are impacting as desired. In this plan, target area 2 examines the manufacturing processes to check the kWh energy usage input utilised to produce 1 tonne of product output. As can be seen from these results of the fourth column in Table 1, there is only a very slight improvement in 2014 compared to 2013 figures. A much more significant improvement would be expected as the wind turbine should be contributing some energy units, therefore bringing down the kWh/tonne of product value.

The turbine produced an annual (2014) output of 288,025 kWh units of electrical energy. This is significantly less than that which the turbine supplier predicted, i.e. an annual energy output of 600,000 kWh units of electrical energy per annum. The capacity factor (CF) of this 300 kW wind turbine is therefore calculated at 10.5 %.

### Estimated Payback Period (PP)

Based on an annual energy output of 288,025 kWh units of electrical energy produced by the turbine in 2014, the following payback period (PP) is estimated. From previous electricity bill analysis, the business uses 72 % of electrical

**Table 2** Increase in production and energy usage

Year on year	Production (%)	Electric energy (%)
2011–2012	Increase by 4	Increase by 26
2012–2013	Increase by 33	Increase by 34
2013–2014	Increase by 10	Increase by 12

energy during day hours and 28 % during night hours. Day units cost €0.1925 per kWh and night units cost €0.0901 per kWh. Annual day monetary savings due to the turbine investment is €39,920  $[(0.72 \times 288,025) \times €0.1925]$  and annual night savings is €7266  $[(0.28 \times 288,025) \times €0.0901]$ . The total annual savings is €47,186. The turbine annual service and maintenance is €4,270. As the initial capital cost is €280,000, the estimated Payback Period is 6.5 years  $[\text{€}280,000 / (\text{€}47,186 - \text{€}4270)]$ .

### Electricity Energy Costs

The data shown in Table 3 compare the SME monthly cost of electrical energy for the years 2013 and 2014. On analysis of the monthly comparisons, there appears little evidence to suggest a 50 % saving as promised by the company selling the wind turbine. These figures indicate that there are little if indeed any monetary savings for the business since the introduction of this wind energy project, so this particular wind turbine installation is not reducing the electricity costs for its investor. The monetary values shown in Table 3 are the total amount payable by the customer. In order to differentiate between different types of costs on each bill, the November 2014 figure is used as an example and is broken up as follows:

- Energy (kWh) costs €14,088 (72 %).
- Capacity charge (kVA) costs €2988 (15 %).
- Public Service Obligation Levy costs €1940 (10 %).
- Energy Management fee costs €571 (3 %).
- Total Cost €19,587 (100 %).

Note that there are no Wattless unit (kVAh) penalties associated with this bill. The cost of the increased MIC value from 320 to 600 kVA was offset by the omission of the ‘excess import capacity’ penalty charges prior to the kVA increase.

**Table 3** Monthly electric energy costs 2013–2014

	2013	2014
Jan	€15,423	€19,514
Feb	€14,028	€17,275
Mar	€13,537	€17,068
Apr	€14,397	€17,609
May	€15,804	€19,913
Jun	€15,154	€17,627
Jul	€20,941	€19,961
Aug	€20,089	€18,372
Sep	€18,227	€20,550
Oct	€19,258	€19,119
Nov	€20,974	€19,587
Dec	€18,478	€18,902

### Power Factor Calculations

The wind turbine installation appeared to coincide with a deterioration in the overall power factor of the installation. This problem necessitated the installation of a new 200 kVA power factor correction (PFC) unit to be installed in the main electrical switch-room in 2014 (Fig. 2). A low power factor, i.e. less than 1, leads to higher currents flowing in circuits causing greater volt drops which also increased energy losses in cables. A low power factor also contributes to difficulties in electrical switching devices sometimes causing arcing at the contacts, thereby reducing the life-time of the switching device. In electrical engineering, the power factor of an AC power system is defined as the ratio of the real power (Watts) to the apparent power (VoltAmps) in the circuit. A load with a low power factor draws more current than a load with a high power factor for the same amount of useful power transferred. The excess current is termed ‘wattless’ current and is not capable of contributing to any work. The low power factor in this case also contributed to the company exceeding their MIC value of 320 kVA on a number of occasions. In 2014, the MIC value was increased from 320 to 600 kVA by the external energy management company. A new 630 kVA supply transformer was also installed, increased from the previous value of 400 kVA. A sample of the power factor values is given in Table 4. Note that the *ideal* power factor is 1.

The power factor values (Table 4) indicate values before the turbine was connected (2013), and also after the turbine was connected (2014).

### Energy Import values with Turbine OFF/ON

As stated in “Data Collection” section, an opportunity arose to compare the energy imported to the factory, while the turbine was switched OFF with the energy imported when it was switched ON, for the same period of time under similar working conditions. Those dates are as follows:

- Friday 30th May 8am to Tuesday 10th June 8am (turbine OFF).
- Friday 13th June 8am to Tuesday 24th June 8am (turbine ON).

The switch off was to facilitate necessary testing and maintenance. Table 5 reports those imported energy values:

**Table 4** Power factor values for comparison

	Jan	Feb	Mar	Apr
2013	0.92	0.923	0.927	0.916
2014	0.687	0.728	0.86	0.82



**Table 5** Comparison of imported units with turbine OFF/ON

	Wind turbine	Day units	Night units	Wattless units
30th May 2014 to 10th June 2014	OFF	28,572	13,716	11,892
13th June 2014 to 24th June 2014	ON	34,452	14,736	16,872

The values in Table 5 indicate an increase in all three imported units when the turbine was switched ON. Note that there is a Bank Holiday Monday on 2nd June 2014 which is not a normal working day for this business. The actual recorded energy values for 2nd June 2014 are 1855 Day kWh units and 1074 Night kWh units. Previous energy bills suggest an average Monday energy usage of 2791 Day kWh's, 821 Night kWh's and 2230 kVAh Wattless units so a slight adjustment must be made to these values. These average Monday working day calculations are obtained from 31st March 2014, 7th April 2014, 14th April 2014, 21st April 2014 and 28th April 2014 stored values. The work load in the factory is constant and very predictable over any seven day period. Tables 6 and 7 in the Appendix show the average daily wind speeds for the significant dates with the 12-day average on the bottom of each column.

Weather data were obtained from The Irish meteorological service (Met Eireann 2015) for average monthly wind speeds for each month in 2014 and also for May and June in 2013 to check if there was any unusual weather events or patterns to emerge during the test period examined. Analysis of the acquired data indicated that on the dates in question, the weather was typical of other similar dates so no external influences can be attributed to these unexpected results. Table 8 in the Appendix shows the wind speed values for this period.

The digital output indicator in the base of the turbine tower (Fig. 1) also indicated a significant number of instances over a protracted period of time where the turbine went into stop mode due to a 'current deviation' error. This error initiated a dispute between the electricity utility supply authorities and the turbine supplier as to the cause of the error. The electrical supply authority recorded the current value in Amps at the supply intake with a high-resolution meter that read values every millisecond. This test identified between 30 and 40 spikes over 1000 Amps, some over 1700 Amps over a 24-h period. A possible cause of such spikes is the switching of large inductive loads. The turbine supplier also recorded the power, voltage and current at the supply intake between the periods 4th April to 11th April 2014. They claimed that even though the factory electrical load was steady between 80 kW and 100 kW, there was 100 voltage dips recorded during this period, and the turbine supplier thus laid the blame on the supply authority for these voltage dips. The final cause of the error was not definitely resolved, but the electricity utility supply authority replaced the 400 kVA supply transformer with a 630 kVA supply transformer and the instance of the error occurring appeared to reduce following this action.

## Discussion

Based on the findings of this study, the expected financial benefits of installing an embedded 300 kW wind turbine generator will not materialise for this business. The business took its CSR issues seriously by this strategic investment but the promises and assurances from the company supplying the turbine did not live up to the expectations of this SME. From an ethical point of view, failure of the turbine seller to seek out the truth regarding the number of units that the turbine would produce on an annual basis cost this company significantly. The net cost of the project was €280,000 and this investment was made on the premise that there would be definitive cost savings for the company as well as fulfilling the desire to adopt green energy strategies within a corporate social responsibility framework. The comparison of the monthly electricity energy costs for 2013–2014 in Table 3 shows that there is no reduction in the company's electricity bill. The data in Table 2 indicate a production increase of 10 % between 2013 and 2014 with a corresponding electrical energy increase of 12 %. There is certainly no evidence to suggest that they are saving 50 % on their bills as promised by the wind turbine seller. Regarding this lack of monetary savings, this author was concerned that in this individual project, the external energy management company failed to highlight the lack of savings, although they continue to be employed by the SME on an ongoing basis to supply the electricity and manage the energy usage within the business, charging 0.4 cent per kWh (approximately €500 per month) for their services.

One of the significant unexpected findings of this piece of research is the fact that the business imported more kWh units of electrical energy when the turbine was switched ON compared to the units imported for exactly the same days and time frame when the turbine was switched OFF. Even allowing for a small correction factor in these values because of the Bank Holiday Monday, 2nd June 2014, the results are contrary to what we expect them to be. The wind speed values shown in Table 7 show that the period between 13th June 2014 and 24th June 2014 when the turbine was switched ON was not a particularly windy period but this does not account for the unexpected results shown. The fact that the turbine had stopped on a number of occasions on a 'current deviation' error as discussed in "Energy Import Values with Turbine OFF/ON" section meant that on start-up, the machine acts as a motor which may account for some of the extra energy imported from the National Grid during this start-up period. The source of

the ‘current deviation’ error is not definitive, and a recording and analysis of the power output of the turbine may yield some fresh insight into this problem.

The connection of the wind turbine in parallel with the electricity supply appeared to have a negative effect on the overall power factor of the installation. This is confirmed by results shown in Tables 4 and 5. This necessitated the purchasing of a power factor correction (PFC) unit at a cost of €4000 to the business owners. In our study, the low power factor necessitated the increase of the MIC value which also has a cost associated with it. Data in Table 5 indicate a large increase in kVArh (Wattless) units of 42 %, when the turbine is embedded with the National Grid, i.e. switched ON, compared with the wattless units when the turbine is not connected, i.e. locked OFF. At the request of the external energy management company, the factory MIC was increased from 320 to 600 kVA and the size of the supply transformer was increased from 400 to 630 kVA. This is not the expected outcome of installing a second embedded source of power/energy, as the expectation is that less imported power/energy is required to power the business premises.

As the variable-output wind turbines require Gas plants as ‘spinning reserve’ (SEAI Report ‘Quantifying Irelands Fuel and CO<sub>2</sub> Emissions Savings from Renewable Electricity in 2012), the advantages of having wind turbines are very questionable particularly as the evidence in this Case Study suggests there is limited if any decrease in kWh units imported to the consumer in this case. The benchmarks used in the Origin Green sustainability plan in Table 1 showed only a very slight improvement in the kWh/tonne of product value for 2014, which is very disappointing. The calculated values are 19.87 kWh/tonne for 2014 and 19.83 kWh/tonne for 2013. This finding would appear to agree with Milne and Gray (2013) who claim that some sustainability reporting businesses do not really change their processes or methods or become more sustainable, and are content to carry on with the status quo. Sustainability reporting is not an end in itself, but an indication of progress or otherwise in the sustainability efforts of the business. Sustainability reporting benchmarks should be an alarm signal for managers to investigate the lack of progress in certain process areas.

There is some research to show that a building management system (BMS) investment with smart metering has the potential to decrease the power demand (Ansani, 2015) using an efficient way to schedule the use of power. Perhaps further research could be carried out to compare the supply-side management philosophy of wind turbine installation with a demand-side philosophy ‘*smart*’ installation on this same site.

There are some factors that may have contributed to the unsatisfactory outcomes of this wind turbine investment.

Significant among these appears to have been ignorance on the part of the turbine seller to claim that the turbine would produce 600,000 kWh units of electrical energy per year. This may not have been a deliberate error but an indicator of knowledge and electrical expertise within the company. The renewable energy company that sold the wind turbine has been in existence for 10 years and specialises in design and installation of renewable energy projects. It markets itself as “one of Irelands leading renewable energy companies, providing a wide range of cost effective renewable energy solutions for its customers”. Indeed it highlights on its website various successful renewable energy projects it has conducted (including the wind energy installation in this case study). However, this research has identified that these savings will not now materialise. Most of the wind turbines installed by this renewable energy company were constructed in 2013. So the low probability of any savings being made has yet to be realised by the other businesses that have undertaken wind energy projects with this wind turbine supplier.

One of the possible barriers to responsible action by the wind turbine supplier involved in this research could stem from the fact that business employees traditionally work as team players and in groups (Costa et al. 2014) This has the potential to overlook an individual’s critical thinking, resulting in a desire not to ‘rock the boat’, as the individual may be seen as an outsider and encourages shared stereotypes of others (Sims and Sausser 2013). This culture of unquestioning deference may also have permeated through the host country, Ireland, and the SME who took on this renewable energy project did not thoroughly investigating the benefits, financial or otherwise of such a venture. It could be argued that the past number of years in Ireland has seen such a culture mushroom throughout many aspects of Irish society, for example, business, political, media, church, social, with many commentators declaring that this relativist, accepting culture, is destroying critical thinking, analytical skills with a reluctance to think outside the box or indeed to declare an opinion outside the box (Sims and Sausser 2013). This researcher, currently lecturing in third-level academia, has no affiliation with any of the companies involved in this research but has some concerns regarding the qualifications and expertise of the employees of the renewable energy supply company. The credentials of the employees of the renewable energy supply company may be significant in this study, and their failure of critical thinking and analytical ability to highlight the possible shortcomings in this venture. More worryingly, if indeed this was identified as a dubious project or if the renewable energy supply company was “unsure of outcomes”, surely from an ethical perspective, there was an onus and moral obligation on the part of the company to highlight possible limitations before large-scale investment was sought (Frederick 1999). Perhaps it is time to encourage a

respectful critical analysis of the energy industry, and those who purport to be experts in the renewable energy fields both on a national and international level.

## Conclusions

The SME in this research is extremely disappointed with their wind energy project, as they attempted to reduce their imported fossil-fuel driven energy usage in line with CSR guidelines. Instead of being a beneficial project for this business, the connection of the embedded wind turbine made things worse for the company. Indeed it would appear that the wind turbine affected a necessary increased MIC and also a deterioration of the power factor with no obvious benefits in terms of reducing the cost of their electric energy bills. Several meetings with the renewable energy turbine provider and adoption of numerous changes to turbine settings have to date failed to yield benefits, and the SME has resigned itself to a “wait and see” attitude.

Interestingly in this research, the external energy management company employed by the SME to supply the electricity and manage the energy usage failed to ‘flag’ any noticeable link between the number of kWh energy units imported pre-turbine and post-turbine installation. This kWh value would have been expected to decrease post-turbine installation but failed to do so. With regard to the deterioration of the power factor, the increasing of the MIC value from 320 to 600 kVA may have only served to mask the problem, without actually identifying any underlying issues that may have contributed to the problem in the first place. The robustness of the energy management function of this external energy management company is therefore questionable. Contributing factors to this apparent failure may be naivety on the part of the SME itself, a lack of knowledge/interest on the part of the external energy management company, or most likely a skills gap in this emerging industry.

On the positive side for the company who made this investment, the aesthetic nature of the on-site wind turbine has been used in some marketing material as the company is perceived to be engaging with their corporate social responsibilities strategically, albeit in a purely aesthetic manner. It is important for a researcher to ensure that their results are generalisable; in this research, the author is aware of the limitations of the Case Study approach and caution is advised in generalisation. Some however would argue that this may not necessarily always be the case, in that there are no absolutes and all truth is relative. Certainly the findings and conclusion of this singular seminal case study call for further detailed studies in this field.

**Acknowledgments** The author wishes to acknowledge the help given by the SME as access to all areas and utility data was very

beneficial in compiling this research study. Thanks also to the Irish Meteorological Service for wind data for three Met Eireann weather sites. A special thank you is due to Olivia for her guidance and support during the writing-up of this research paper.

**Open Access** This article is distributed under the terms of the Creative Commons Attribution 4.0 International License (<http://creativecommons.org/licenses/by/4.0/>), which permits unrestricted use, distribution, and reproduction in any medium, provided you give appropriate credit to the original author(s) and the source, provide a link to the Creative Commons license, and indicate if changes were made.

## Appendix

See Tables 6, 7 and 8.

**Table 6** Wind Speeds—30th May to 10th June

2014	Wind speed in m/s		
	Dublin airport	Dunsany	Mullingar
30th May	3.7	2.4	1.5
31st May	3.4	2.6	1.9
1st June	4.3	3.4	3
2nd June	4.1	3.3	2.2
3rd June	4.1	3.3	2.6
4th June	5.6	3.9	2.8
5th June	4.3	2.6	1.9
6th June	5.2	4.5	4.1
7th June	4.6	3.4	3.7
8th June	5.9	4.4	4.4
9th June	5.8	3.3	3.7
10th June	3.7	3.2	2.7
Average	4.6 m/s	3.4 m/s	2.9 m/s

**Table 7** Wind speeds—13th June to 24th June

2014	Wind speed in m/s		
	Dublin airport	Dunsany	Mullingar
13th June	2.8	2	1.5
14th June	3	2	1.7
15th June	3.7	2.5	1.7
16th June	3.5	2.7	2.2
17th June	2.3	1.8	1.5
18th June	2.7	2.3	1.9
19th June	4.8	3	2.3
20th June	3.3	2.3	1.9
21st June	3.7	2.5	2.1
22nd June	3.5	2.4	1.8
23rd June	2.8	1.9	1.7
24th June	2.3	1.7	1.5
Average	3.2 m/s	2.3 m/s	1.8 m/s

**Table 8** Monthly average wind speeds for 2014 and May/June 2013

	DA WSp Knots	DA WS m/s	Dunsany WSp Knots	Dunsany WS m/s	Mullingar WSp Knots	Mullingar WS m/s
Jan-14	12.7	6.5	9.8	5	7.3	3.8
Feb-14	15.9	8.2	12.3	6.3	9.3	4.8
Mar-14	12.1	6.2	9.1	4.7	6.6	3.4
Apr-14	9.8	5	8	4.1	6.3	3.2
May-14	9.9	5.1	7.5	3.9	5.6	2.9
Jun-14	7.6	3.9	5.5	2.8	4.6	2.4
Jul-14	8.7	4.5	6.5	3.3	4.9	2.5
Aug-14	11.4	5.9	8	4.1	5.7	2.9
Sep-14	6.5	3.3	5.1	2.6	3.9	2
Oct-14	11.5	5.9	8.6	4.4	6.5	3.3
Nov-14	9.1	4.7	6.5	3.3	5.2	2.7
Dec-14	13.9	7.2	9.7	5	6.8	3.5
		5.5		4.1		3.1
May-13		6.1		4.7		3.6
Jun-13		4.8		3.7		2.8

## References

- Ansani, G. A. (2015). Role of smart meter in demand side management for future smart grids. *International Journal of Technology and Research*, 3(1), 7–14.
- Aspling, A. (2013). Business, management education, and leadership for the common good. In D. L. Everett (Ed.), *Shaping the future of business education: Relevance, rigor and life preparation* (pp. 40–58). New York: Palgrave Macmillan.
- Besio, C., & Prozini, A. (2014). Morality, Ethics, and values outside and inside organisations: An example of the discourse on climate change. *Journal of Business Ethics*, 119(3), 287–300.
- Bord Bia. (2015) Working with Nature: an Initiative by Bord Bia, Irish Food Board. <http://www.origingreen.ie/>. Accessed on 7th March 2015.
- Brusseau, J., Chiagouris, L., & Fernandez Brusseau, R. (2013). Corporate social responsibility: To yourself be true. *Journal of Global Business and Technology*, 9(1), 53–63.
- Catalin, C., & Nicoleta, R. (2011). International biomass trade and sustainable development: An overview. *Annals of the University of Oredea, Economic Science Series*, 20(2), 47–54.
- Costa, P. L., Passos, A. M., & Bakker, A. B. (2014). Team work engagement: A model of emergence. *Journal of Occupational and Organisational Psychology*, 87, 414–436.
- Department of Communications, Energy and Natural Resources (DCENR). <http://www.dcenr.gov.ie>. Accessed on 12th March 2015.
- Doha. (2012) Doha Amendment to the Kyoto Protocol. [http://unfccc.int/kyoto\\_protocol/doha\\_amendment/items/7362.php](http://unfccc.int/kyoto_protocol/doha_amendment/items/7362.php). Accessed on 20th October 2014.
- Elkington, J. (1997). *Cannibals with forks; the triple bottom line of 21st century business*. Oxford: Capstone Publishing.
- Frederick, R. E. (1999). *A companion to business ethics*. Oxford: Blackwell Publishers Ltd.
- Gray, D. E. (2009). *Doing research in the real world* (2nd ed.). London: Sage Publications.
- Henaghan, D. (2013). *Analysis of the capacity factor of Irish wind energy, dissertation as part of the MSc in energy management (d711)*. Dublin: Dublin Institute of Technology.
- Kealy, T. (2014a). Financial appraisal of a small-scale wind turbine with a case study in Ireland. *Journal of Energy and Power Engineering*, 8(4), 620–627.
- Kealy, T. (2014b). Sustainable business development: An Irish perspective. *International Journal of Humanities and Social Science*, 4(12), 166–179.
- Kose, F., Aksoy, M. H., & Ozgoren, M. (2014). An assessment of wind energy potential to meet electricity demand and economic feasibility in Konya, Turkey. *International Journal of Green Energy*, 11(6), 559–576.
- Kyoto (1997) Kyoto protocol, United Nations framework convention on Climate Change. [http://unfccc.int/kyoto\\_protocol/items/2830.php](http://unfccc.int/kyoto_protocol/items/2830.php). Accessed on 20th October 2014.
- Met, E. (2015). The Irish meteorological service. <http://www.met.ie/>. Accessed on 7th March 2015.
- Milne, M. J., & Gray, R. (2013). ‘W(h)ither ecology? The triple bottom line, the global reporting initiative, and corporate sustainability reporting. *Journal of Business Ethics*, 118, 13–29.
- RIO + 20, United Nations Conference on Sustainable Development. <http://www.uncsd2012.org>. Accessed 12th March 2015.
- Shafiee, S., & Topal, E. (2009). When will fossil fuel reserves be diminished? *Energy Policy*, 37(1), 181–189.
- Sims, R. R., & Sauser, W. I. (2013). Towards a better understanding of the relationships among received wisdom, groupthink, and organisational ethical culture. *Journal of Management Policy and Practice*, 14(4), 75–90.
- Sustainable Energy Authority of Ireland. (2012) Quantifying Irelands Fuel and CO<sub>2</sub> Emissions Savings from Renewable Electricity in 2012. [http://www.seai.ie/Publications/Statistics\\_Publications/Energy\\_Modelling\\_Group\\_Publications](http://www.seai.ie/Publications/Statistics_Publications/Energy_Modelling_Group_Publications). Accessed 11th March 2015.
- Sustainable Energy Authority of Ireland. (2013) Renewable Energy Policy. [http://www.seai.ie/Renewables/Renewable\\_Energy\\_Policy/](http://www.seai.ie/Renewables/Renewable_Energy_Policy/). Accessed on 12th March 2015.
- Van Der Ploeg, L. and Vanclay, F. (2013) Credible Claim or Corporate Spin? A checklist to Evaluate Corporate Sustainability Reports, *Journal of Environmental Assessment Policy and Management*. 15(3), 21.
- Yin, R. K. (2003). *Case study methods: Design and methods* (3rd ed.). Thousand Oaks, CA: Sage.