

ISTITUTO DI FISICA - UNIVERSITA' DI CATANIA
SEZIONE DI CATANIA
CENTRO SICILIANO DI FISICA NUCLEARE E STRUTTURA DELLA MATERIA, CATANIA.

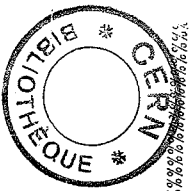

07 DEC. 1982

PP/693

G.D. MACCARRONE and Erasmo RECAMI

THE INTRODUCTION OF SUPERLUMINAL LORENTZ TRANSFORMATIONS:
A REVISITATION

NR
February, 1982

Address: 57, CORSO ITALIA - 95129-CATANIA - ITALY

CIFT-PP 693

THE INTRODUCTION OF SUPERLUMINAL LORENTZ TRANSFORMATIONS:
A REVISITATION.(*)

G. D. Maccarrone and Erasmo Recami

Abstract - We revisit the introduction of the Superluminal Lorentz transformations which carry from "bradyonic" inertial frames to "tachyonic" inertial frames, i.e. which transform time-like objects into space-like objects and vice-versa. It is known since long that Special Relativity can be extended to Superluminal observers only by increasing the number of dimensions of the space-time or —which is in a sense equivalent— by releasing the reality condition (i.e., introducing also imaginary quantities). In the past we always adopted the latter procedure. Here we show the connection between that procedure and the former one. In order to clarify the physical meaning of the imaginary units entering the classical theory of tachyons —in other words, — we have temporarily to call into play an auxiliary six-dimensional space-time $M(3,3)$; however, we are eventually able to go back to the four-dimensional Minkowski space-time.

We revisit the introduction of the Superluminal Lorentz transformations also so under another aspect. In fact, the Generalized Lorentz transformations had been previously written down in a form suited only for the simple case of collinear boosts (e.g., they formed a group just for collinear boosts). We express now the Superluminal Lorentz transformations in a more general form, so that they constitute a group together with the ordinary —orthochronous and antichronous— Lorentz transformations, and reduce to the previous form in the case of collinear boosts.

Our approach introduces either real or imaginary quantities, with exclusion of (generic) complex quantities. In the present context, a procedure —in two steps— for interpreting the imaginary quantities is put forth and discussed. In the case of a chain of Generalized Lorentz transformations, such a procedure (when necessary) is to be applied only at the end of the chain. At last, we justify why we call "Transformations" also the Superluminal ones.

(*) Paper partially supported by M.P.I. and C.N.R.

THE INTRODUCTION OF SUPERLUMINAL LORENTZ TRANSFORMATIONS:
A REVISITATION. (°)

G.D.Maccarrone and Erasmo Recami

1 = INTRODUCTION

The Generalized Lorentz "transformations" (GLT), introduced by Mignani and Recami⁽¹⁻⁶⁾ had some good properties, being, e.g. linear, leaving the light-speed still invariant, and preserving space-time homogeneity and space isotropy.

However, those GLT's were written explicitly down in a four-dimensional form⁽⁷⁾ which was suited only for collinear boosts, in the sense that they formed a group only under (generalized, i.e. both subluminal and Superluminal) boosts along one and the same direction. For instance, the composition of two successive collinear boosts yielded a "transformation" of the same group, but two boosts along different directions didn't.

Our main aim is revisiting the introduction of Superluminal Lorentz "transformations" (SLT), so to give the GLT's a form satisfying the standard group-properties and which reduces to the previous form in the particular case when only collinear boosts are considered. The sense in which the SLT's and GLT's may be called "transformations" will be also clarified.

In so doing, we shall show that our approach uses only quantities either real or imaginary, without any intervention of generically complex quantities.

Moreover, we shall investigate the physical meaning of the imaginary quantities entering our new SLT's, by temporarily calling into play an auxiliary six-dimensional space-time M(3,3). Actually, it is known that a good group of GLT's (including SLT's) could be constructed only in a 2n-dimensional space-time M(n,n), or —which is substantially equivalent— by suitably releasing the reality condition. A "model theory" in two dimensions (n=1) can be easily extracted from Refs.⁽¹⁻⁸⁾. Here we shall consider the realistic case n=3;

even if our theory is essentially a 4-dimensional one, since it implies that every observer has access only to a suitable four-dimensional slice. The price paid for "going back" to four dimensions is in a sense that tachyons should be described by three time-coordinates and one space-coordinate: this shows up in the formal fact that the transversal coordinates are imaginary. It is such

(°) Paper partially supported by M.P.I. and C.N.R.

imaginary quantities that are geometrico-physically interpreted in the context of an analysis of the apparent shape of tachyons.

Various further points will be analysed.

2 = THE POSTULATES OF (EXTENDED) RELATIVITY

Let us assume the ordinary Postulates of Special Relativity (SR), in the following form:

- 1) Principle of Relativity: (The physical laws of Mechanics and Electromagnetism are covariant when passing from an inertial frame f to another frame moving with constant velocity \vec{u} relative to f; where, a priori, $-\infty < |\vec{u}| < +\infty$).
- 2) The space-time of the events accessible to any inertial observer is four-dimensional and Minkowskian: To each (inertial) observer the 3-dimensional Space appears as homogeneous and isotropic, and the 1-dimensional Time appears as homogeneous.(*) Let us add the following observations: (i) The words homogeneous, isotropic refer —as always— to the assumed properties of space-time with respect to the mechanical and electromagnetic phenomena; (ii) Such properties of space-time are supposed by the present postulate to be covariant within the class of the inertial frames; this means in other words that SR assumes the vacuum (i.e. space) to be "at rest" with respect to all inertial frames.

Usually, in "Extended Relativity" (ER), it is assumed also a Third Postulate (inspired to the requirement that for each observer "causes" and "effects" must appear to follow each other in the ordinary chronological order^(2,5)), which reads: <<Negative-energy objects, travelling forward in time, do not exist>>, wherefrom it followed that for every observer even positive-energy objects travelling back-

(*) However, to enforce the equivalence⁽⁴⁾ of all inertial frames, we shall temporarily need introducing an auxiliary six-dimensional space-time M(3,3) as the abstract kinematical background in which the events are a priori allowed to happen. Eventually, however, we shall go back —for every observer— to the four-dimensional M(1,3) space-time.

wards in time do not exist. However, in this paper we do not need discussing in detail the Third Postulate, since we shall merely make recourse to its "corollary" known as the

3) "Reinterpretation Principle" (RIP), for which we refer to (2-5).

From Postulates 1) and 2) the existence follows of one—and only one—invariant speed w . We get from experience that $w=c$. Once an inertial frame f_0 is chosen, the invariant character of the speed of light allows to divide the set $\{f\}$ of all inertial frames f into two complementary, disjoint subsets $\{s\}$, $\{S\}$, where frames s are subluminal and frames S Superluminal with respect to f_0 . The Principle of Relativity requires observers s and S to be equivalent(2,4), and, in particular, observers S to have at their disposal rods, clocks, protons, electrons... like observers s . Of course(1-6), objects which are bradyons B (slower than light) with respect to a frame S must appear as tachyons T with respect to any frame s , and vice-versa:

(1) $B(S) = T(s); T(S) = B(s); \mathcal{L}(S) = \mathcal{L}(s),$

where \mathcal{L} represents the "Luxons". The main problem of the theory of tachyons is finding how objects that are subluminal with respect to observers S will appear to observers s (i.e., to us). To solve such a problem, it is necessary to find out the (Superluminal) Lorentz transformations connecting the observations by S with the observations by s .

From our Postulates 1) and 2) it follows also that the (Generalized) Lorentz transformations $G_{\mu\nu}$ connecting two generic inertial frames f, f'

(2)
$$dx_{\mu}' = G_{\mu\nu} dx_{\nu}$$

must:

- (i) transform inertial motion into inertial motion;
- (ii) form a (new) group G ;

(iii) preserve space isotropy;

(iv) leave the chronotopical-interval square invariant, except for its sign(2,8) (-)

(3)
$$dx_{\mu}' dx'^{\mu} = \pm dx_{\mu} dx^{\mu} \quad [u^2 \geq c^2]$$

Due to eq.(1), the plus sign holds for ordinary subluminal Lorentz transformations (LT) and the minus sign for Superluminal Lorentz transformations (SLT). Notice that eq.(3) imposes the light-speed to be invariant.

Notice explicitly that the four-position x^{μ} , entering eq.(3), is supposed to be a vector even with respect to the Generalized Lorentz group G , according to eq.(2). It follows that in ER the quadratic form

$$dx_{\mu} dx^{\mu}$$

is a scalar under LT's, but it is a pseudoscalar under SLT's (i.e., under the symmetry operation S : see the following).

In other words, the requirement (iv) above —together with requirement (i) — means that the GLT's must be special and unimodular

(4)
$$\det G = +1, \quad \forall G \in G,$$

and such that the LT's are orthogonal whilst the SLT's are anti-orthogonal:

(5a)
$$G^T G = +\mathbb{1}, \quad (\text{subluminal case: } u^2 < c^2)$$

(5b)
$$G^T G = -\mathbb{1}. \quad (\text{Superluminal case: } u^2 > c^2)$$

The present considerations are explicitly expounded in Appendix A, since they are delicate enough—even if straightforward—to have aroused some misunderstandings in the past literature(9).

We shall see soon that a group of GLT's (including the SLT's, and satisfying our conditions (i)-(iv)) can be built up only passing to a $2n$ -dimensional space-time ($n \geq 3$), or—which is substantially equivalent—suitably relaxing the reality condition. Due to our Postulate 2), however, we shall follow an approach such to allow us to go back to four dimensions. A "model theory" in (only) two dimensions ($n=1$) can be easily extracted from Refs.(1,2,8).

* * *

★ ★ ★

We already know the form of the ordinary LT's satisfying our conditions (i)-(iv), with the sign plus in eq.(3), i.e. the subluminal LT's (which, according to eq.(5a), are orthogonal transformations).

We are left with the problem of constructing the SLT's, i.e. the transformations satisfying conditions (i)-(iv), with the sign minus in eq.(3) (and which, according to eq.(5b), are anti-orthogonal).

By attempts, it is easy to write down "Superluminal" transformations which are real and satisfy three of the four conditions (i)-(iv) in four dimensions; in other words, it is easy to write down (in 4 dimensions) real "Superluminal" transformations which violate —however— one condition of ours (e.g., which violate linearity, or light-speed invariance).

We, however, would like to preserve the fundamental postulates 1),2),3) of SR, i.e. all our four conditions. To such an aim, we have e.g. to release the ordinary reality condition, accepting to deal with both real and imaginary numbers. We shall later try to explain the geometrico-physical meaning of this fact.

In Ref.(10) it was actually shown that no real generalizations to Superluminal velocities of Lorentz transformations exist, which satisfy our conditions (i)-(iv) in four dimensions. We have therefore either to increase the dimensionality of space-time, or to abandon the field of real numbers.

3 = SUPERLUMINAL LORENTZ TRANSFORMATIONS

The Superluminal Lorentz transformations differ from the subluminal ones only for the fact that they are anti-orthogonal, i.e. that (cf. eq.(3)) they must yield:

(6) $dx^\mu dx^\mu = - dx_\mu dx^\mu$ $[u^2 > c^2]$

(-) To compare the present language with the one usual in Riemannian spaces, see the end of Appendix A. Cf. also footnote (**).

still, however, with (see Appendix A)(**)

(7) $g'_{\mu\nu} = g_{\mu\nu}$

In other words, a Lorentz transformation SLT from a sub- to a Super-luminal frame, $s \rightarrow S'$, can be identical to a suitable (ordinary) subluminal LT —let us call it the "dual" transformation—, except for the fact that it must moreover change time-like into space-like quantities, and vice-versa, according to eqs.(6),(7).(**)

Alternatively, one might also say that a SLT is identical to its dual, subluminal LT, provided that we impose that the primed observer S' uses the opposite metric signature $g'_{\mu\nu} = -g_{\mu\nu}$ [however, without changing the signs into the definitions of time-like and space-like quantities!].(2,11)

From the last two paragraphs, it follows that a generic SLT, corresponding to a velocity \vec{u} , will be formally expressed by the product of the dual (subluminal) LT, corresponding to the velocity $\vec{u} // \vec{u}$, with $u \equiv c^2/u$, by the matrix $S \equiv$

(8) $SLT(\vec{u}) = \pm i [LT(\vec{u})]$, $[\vec{u} // \vec{u}; u = c^2/u]$

where the imaginary unit i takes care, in particular, of requirements (6),(7) since it is $i^2 = -1$.

If we now recall from Ref.(2) the "fundamental relation" of SLT's

(9) $SLT(\vec{u}) = S \cdot [LT(\vec{u})]$, $[\vec{u} // \vec{u}; u = c^2/u]$

we recognize that(**)(13)

(10) $S \equiv \pm i \mathbb{1}; S \in \mathbb{C}$,

where operator S plays the rôle of "transcendent SLT", since from eq.(8) when $\vec{u} \rightarrow 0$ one gets

(**) Conversely, one might substitute eq.(6) with eq.(A5) and eq.(7) with eq.(A7'). We prefer our choice, however, since it is more directly compatible with the Principle of Relativity (equivalence of all inertial frames, both sub- and Super-luminal).

(*) In eqs.(8),(10), instead of the imaginary unit i , we might have introduced the 4-vector (in Hestenes' sense) ϵ ; cf. e.g. Ref.(13).

(10') $SLT(U=\infty) = \pm i \mathbb{1}$.

We are calling "transformations" the SLT's, and not mappings, for the reasons we shall see later.

The present derivation improves our previous approach, contained in Refs. (1-7), by modifying it, with the consequences that we shall soon expound.

In particular, the transcendent "transformation" S is simply given by eq. (10), and does not affect the speed u (i.e., does not operate any change $\beta \rightarrow 1/\beta$, differently from what stated in Refs. (3,4)). In fact, it is easy to recognize that —under our hypotheses— the group properties and space isotropy are preserved only by an operator S which be represented by a 4 x 4 matrix symmetrical with respect to all the possible axis-permutations. Of course, consistently with eqs. (4), (5),

(11) $\det S = +1; \quad S^T S = -\mathbb{1}$.

Let us recall (1-7) also that, if G is a generalized Lorentz "transformation", then also $-G$ is a GLT:

(12) $G \in \mathbb{G} \Rightarrow -G \in \mathbb{G}, \quad \not\forall G \in \mathbb{G};$

this is the reason of the double sign in eqs. (8), (10), (10'). Cf. also Fig. 12 in Ref. (2). In particular, let us consider the SLT = $+i\Lambda(\vec{u})$, where $\Lambda(\vec{u})$ is a certain (subluminal) LT; we get (2)

(13a) $[i\Lambda(\vec{u})][-i\Lambda^{-1}(\vec{u})] = [i\Lambda(\vec{u})][-i\Lambda(-\vec{u})] = +\mathbb{1}$,

but

(13b) $[i\Lambda(\vec{u})][+i\Lambda^{-1}(\vec{u})] = [i\Lambda(\vec{u})][+i\Lambda(-\vec{u})] = -\mathbb{1}$.

Eqs. (13) show, by the way, that (2)

(14) $[i\Lambda(\vec{u})]^{-1} = -i\Lambda^{-1}(\vec{u}) = -i\Lambda(-\vec{u})$.

If we call Z(n) the discrete group of the n-th roots of unity, then the new group \mathbb{G} of GLT's (both sub- and Super-luminal) results to be (1-7):

(15) $\mathbb{G} = Z(4) \otimes \mathcal{Z}_+^4$,

where \mathcal{Z}_+^4 is the ordinary (proper, orthochronous) Lorentz group, and Z(4) is the discrete group of the four fourth-roots of unity:

(16) $Z(4) \equiv \{+1, -1, +i, -i\}$.

See Fig. 1.

By adding the ordinary translations Π_4 , we get the generalized Poincaré group \mathbb{P} . One of the Casimir invariants of \mathbb{P} is now m_0^4 (and no more m_0^2). More in general, the corresponding Casimir invariant of the group $\mathbb{P}(n) = \mathbb{G}(n) \otimes \Pi_4$, with $\mathbb{G}(n) = Z(n) \otimes \mathcal{Z}_+^n$, is m_0^n ; in fact, the groups $\mathbb{P}(n)$, $\mathbb{G}(n)$ leave ds^n invariant. Of course, in our notations, $\mathbb{G} \equiv \mathbb{G}(4)$; $\mathbb{P} \equiv \mathbb{P}(4)$.

In the ordinary case of SR, the true Lorentz group is (4,5): $[Z(2) \equiv \{+1, -1\}]$

(17) $\mathbb{G}(2) = Z(2) \otimes \mathcal{Z}_+^4 \equiv \mathcal{Z}_+^4 \cup \mathcal{Z}_-^4$

which describes both particles and anti-particles in purely relativistic terms (merely by making recourse to the standard postulates of SR, including the Third Postulate: Cf. Refs. (4,5)). In this case, as well known, that Casimir invariant reduces to m_0^2 .

In the particular case of a boost along x, our SLT's, eqs. (9)-(10), write (2): $[U \equiv 1/u]$

(18)
$$\begin{cases} t' = \pm \frac{t - ux}{\sqrt{1-u^2}} = \pm \frac{t - Ut}{\sqrt{U^2 - 1}}; \\ x' = \pm \frac{x - ut}{\sqrt{1-u^2}} = \pm \frac{t - Ux}{\sqrt{U^2 - 1}}; \\ y' = \pm iy; \\ z' = \pm iz. \end{cases} \quad \left[\begin{array}{l} \text{Superluminal case} \\ U^2 < c^2; \quad U^2 > c^2 \end{array} \right]$$

Let us ^{repeat} that one of the ways for understanding the formal presence of the "i's"

(*) Throughout this paper, when convenient, we shall use natural units: $c=1$.

in eqs.(18) is the following: They represent the fact, discussed in connection with eq.(8), that a Superluminal boost can be considered as identical with its dual subluminal boost, provided that the second (Superluminal) observer S' uses the opposite metric-signature^(2,1) [in the sense previously specified, i.e. without changing simultaneously the signs into the definitions of time-like and space-like quantities]. A consequence of this fact is that, under "transformations" (18), the four-velocity⁽⁶⁾ u_μ changes in such a way that $u^\mu u_\mu = -u^\mu u_\mu$. Eqs.(18), therefore, are associated with Superluminal motion, notwithstanding their appearance. For the detailed interpretation of eqs.(18) see Sects. 6 & 8 in the following. (Again, we call eqs.(18) a "transformation" —instead of a mapping— for the reasons we shall see).

In eqs.(18) we took advantage of the important symmetry-property of ordinary Lorentz boosts^(3,4,6) expressed by the identities:

$$(19) \quad \begin{cases} \frac{t - ux}{\sqrt{1-u^2}} \equiv -\frac{x - ut}{\sqrt{1-u^2}} \\ \frac{x - ut}{\sqrt{1-u^2}} \equiv -\frac{t - ux}{\sqrt{1-u^2}} \end{cases} \quad [U \equiv 1/u]$$

Notice that eqs.(18) have a form different from the one previously adopted^(1,7) for the SLT's, even if they will be eventually reduced to the old form after their (partial) interpretation.

In their present form, given by eqs.(8)-(10) and particularly (18), our SLT's do form a group. Their old form^(1,7), on the contrary, was suitable only for collinear boosts; so that our previous equations for SLT's (see Refs.(7)) actually formed a group —in that form— only for collinear boosts.

Before closing this Section, let us re-emphasize that our transcendent "transformation" $S = \pm i \mathbb{1}$, eq.(10), i.e. the SLT corresponding to infinite relative speed, a priori does not depend on any space-direction, analogously

(6) See Sect. 4.

to the transformation $LT(u=0) = \pm \mathbb{1}$ which corresponds to zero relative speed^(1,5). This accords with the known fact that the infinite speed plays for tachyons (T) a rôle similar to the one played by the null speed for bradyons (B): more in general, it exists (cf. eqs.(8),(9)) the following "dual" correspondence between subluminal and Superluminal velocities⁽¹⁻⁶⁾:

$$(20) \quad u \rightarrow c^2/u \equiv U; \quad \vec{u} // \vec{U}.$$

At this stage, ER seems to suggest that, as one usually associates no direction to the zero speed, so one should not associate any direction with the divergent speed. One ought therefore to identify all the points of the hyperplane $E=0$ in the fourmomentum space; i.e., to add to the 3-velocity space only one "ideal" point at infinity. Accepting such a procedure, the inversion (20) —which is a very particular conformal mapping— would yield a one-to-one correspondence between sub- and Super-luminal speeds (and frames without rotation).

Alternatively, one might add to ER a prescription (cf. footnote (16) in ref.(4)) to assign a direction both to zero and to infinite speeds.

We shall re-examine this point when interpreting the SLT's given by eqs.(18).

4 = G-VECTORS AND G-TENSORS

Our eqs.(18) introduce x^μ as a G-vector; in other words, by definition of GLT's, x^μ is a fourvector not only with respect to the group \mathcal{A}_4 but also with respect to the whole group \mathcal{G} . As a consequence (cf. Sect.2), the "scalar product" $dx_\mu dx^\mu$ behaves as a pseudo-scalar under the symmetry-operation S (i.e., it is a scalar under LT's and a pseudo-scalar under SLT's).

Under SLT's it is $ds'^2 = -ds^2$; it follows that quantity $u^\mu \equiv dx^\mu/ds$, a Lorentz vector, is not a G-vector. In order to define the four-velocity as a G-vector we must set⁽²⁾:

$$(21) \quad u^\mu \equiv \frac{dx^\mu}{dt_0}$$

where t_0 is the proper-time. Analogously for the four-acceleration

$$(21') \quad a^\mu \equiv \frac{du^\mu}{dt_0}$$

and so on. From ref. (2), let us recall that the electromagnetic quantities A^μ (Lorentz vector) and $F^{\mu\nu}$ (Lorentz tensor) do not result to be any more a G-vector and a G-tensor, respectively).

However, if $T^{\mu\nu}$ is supposed to be a G-tensor, then under a GLT:

$$(22) \quad T^{\mu\nu} = g^\mu_\alpha g^\nu_\beta T^{\alpha\beta}$$

wherefrom it follows that the ordinary invariants

$$(22') \quad T_{\mu\nu} T^{\mu\nu}; \quad \epsilon_{\mu\nu\alpha\beta} T^{\mu\nu} T^{\alpha\beta}$$

are still invariant (even under SLT's). (2) This holds, of course, only for rank-2 tensors (or, more generally, for even-rank tensors).

From what precedes, it follows in particular — as we already mentioned — that, if we define the four-velocity u^μ by eq. (21) so to be a G-vector, then under a SLT the quantity $u^2 \equiv u_\mu u^\mu$ becomes

$$(23) \quad u'^2 = -u^2.$$

Eq. (23) tells us that, if $u^2 = +1$, then $u'^2 = -1$; that is to say, after a SLT a bradyonic velocity is seen as a tachyonic velocity, and vice-versa. [in agreement with the "duality principle" (1,2) as expressed by eqs. (1)].

We shall pass to the problem of suitably introducing the 3-velocity for tachyon motion only after having discussed the physical interpretation of SLT's, eqs. (8)-(10), (18).

5 = THE INTRODUCTION OF THE AUXILIARY SIX-DIMENSIONAL SPACE-TIME M(3,3)

We have now to consider the problem of physically interpreting the meaning of SLT's as given by eqs. (8)-(10). Let us specify that we adopt the metric (+---), which in the following will be always supposed to be used by both sub- and super-luminal observers (unless differently stated in an explicit way).

Whenever convenient, however, one could avoid explicit use of a metric tensor by making recourse to Einstein's notations and by writing the generic chronotopical vector as $x \equiv (x_0, x_1, x_2, x_3) \equiv (ct, ix, iy, iz)$, so that $g_{\mu\nu} \equiv \delta_{\mu\nu}$ ("Euclidean" metric). As a consequence, one would not have to distinguish any more between covariant and contravariant components.

In such a case, since one has practically to deal with a complex manifold, the quadratic form which is Lorentz-invariant should be defined as the scalar product of the first vector by the complex conjugate of the second vector:

$$\text{quadratic form} \equiv (x, \bar{y}) = x_\mu \bar{y}^\mu;$$

in particular the invariant square interval would be

$$s^2 = (x, \bar{x}) = x_\mu \bar{x}^\mu.$$

Eqs. (8)-(10), as well as (18), call imaginary quantities into play and therefore seem to require an eight-dimensional space C^4 (i.e. a four-dimensional complex space-time) as the kinematical background. However, let us recall that a very essential teaching of Special Relativity appears to be that four-position is given by one real coordinate and three imaginary coordinates — or vice-versa —, so that formally:

$$(24) \quad \text{time} = i \times \text{space};$$

$$[c = 1]$$

as noticed by Minkowski (12) himself, in natural units we may formally write:

(24') $1 s = i \cdot (3 \times 10^8) \text{ m}.$

As a consequence, to interpret the SLT's it is enough to assume temporarily as background a six-dimensional space-time $M(3,3)$. It is wellknown⁽¹⁻⁵⁾, incidentally, that the introduction of tachyons becomes straightforward when a symmetry is assumed between the allowed number of space coordinates and time coordinates^(14,15).

Let us explicitly emphasize, however, that the present introduction of a $M(3,3)$ space-time —see Figs.2— constitutes only an intermediate step, since by the action of our Postulate 2 (in Sect.2) we shall eventually end up with the ordinary four-dimensional space-time $M(1,3)$ for every observer. This accords with the fact that even in our previous formulation⁽¹⁻⁶⁾ the fundamental laws of tachyon classical physics are expressible in purely real terms^(2,6). Moreover, whenever a relativistic equation can be written down in terms of Lorentz invariants only, the passage from the bradyon case to the tachyon case is got simply by changing sign to the (quadratic) invariants.

Aim of the following Sections is interpreting the SLT's, eqs.(8)-(10), first of all in the simple case of a 4-dimensional boost along an axis; let it be the x-axis. We are left with the problem of discussing eqs.(18).

$\bar{6} = \text{ABOUT GLT'S IN THE SPACE } M(3,3)$

Let us consider the GLT's, given by eqs.(4)-(5) and (8)-(10), as defined in a six-dimensional space-time $M_6 \equiv M(3,3) \equiv (x, y, z, t, t_x, t_y, t_z)$. In the (auxiliary) 6-dimensional space-time any observer s is free to rotate the triad $(t_x, t_y, t_z) \equiv (\vec{t})$, provided that $(\vec{t}) \perp (\vec{x}) \equiv (x, y, z)$.

Let us recall that the GLT's can be conceived as suitable, generalized "rotations" (see eq.(4)) in the six-dimensional $M_6 \equiv M(3,3)$ space-time: Namely, as suitable "rotations" in the subluminal case (since LT's are orthogonal), and as suitable "pseudo-rotations" in the Superluminal case (since SLT's are anti-orthogonal). Cf. eqs.(4)-(5) and Ref.⁽²⁾.

In particular, the initial observer s_0 can always choose the axes t_x, t_y, t_z in such away that under a transcendent Lorentz transformation (without rotations⁽¹⁷⁾) $S_6 \equiv S$ in M_6 :

(25) $x \rightarrow t_x; y \rightarrow t_y; z \rightarrow t_z; t \rightarrow x; t_x \rightarrow y; t_y \rightarrow z$ [for any transcendent SLT],

in agreement with the fact that the formal expression of S is independent of any space direction (cf. end of Sect.3):

(10) $S \equiv \pm 1 \mathbb{1}$,

where now quantity $\mathbb{1}$ is to be regarded as the 6-dimensional identity.

Moreover, if observer s_0 , when aiming to perform a Superluminal boost along x_i , rotates (\vec{t}) so that $t_i \equiv t$ (axis t being his ordinary time-axis: see the following), then one may write:

- (26a) transcendent x-boost: $t_x \rightarrow t_x \equiv x; x \rightarrow x' \equiv t; y \rightarrow y' \equiv t_y; z \rightarrow z' \equiv t_z; t \rightarrow t' \equiv y; t_y \rightarrow t_z; t_z \rightarrow t_x$;
- (26b) transcendent y-boost: $t_y \rightarrow t_y \equiv y; y \rightarrow y' \equiv t; x \rightarrow x' \equiv t_x; z \rightarrow z' \equiv t_z; t \rightarrow t' \equiv x; t_x \rightarrow t_z; t_z \rightarrow t_y$;
- (26c) transcendent z-boost: $t_z \rightarrow t_z \equiv z; z \rightarrow z' \equiv t; x \rightarrow x' \equiv t_x; y \rightarrow y' \equiv t; t \rightarrow t' \equiv x; t_x \rightarrow t_y; t_y \rightarrow t_z$;

Eqs.(26) mean that (formally) any transcendent boost can be described to operate so as in Fig.2b.

Actually, what precedes (in particular eqs.(25)) means that the imaginary unit i can be considered as a 90°-rotation operator also in the auxiliary, 3-temporal (6-dimensional) space-time; namely, as an operator which —e.g., from the active point of view— carries

(27) $\vec{x} \equiv (x, y, z) \xrightarrow{i} (t_x, t_y, t_z) \equiv \vec{t}.$

Here the meaning —for one and the same observer— of quantity i is analogous to its meaning in ordinary SR, where it is used to distinguish the time-coordinate from the space-coordinates (which are orthogonal to time). Moreover, eq.(27) generalizes to the (3+3)-dimensional case what is wellknown to happen in the (1+1)-dimensional case; in fact, in the two-dimensional case (i.e., in

the complex plane (x, t) it holds $t \equiv \exp(+i\pi/2)$. In conclusion:

$$(27') \quad t \equiv e^{i\pi/2} \begin{matrix} \swarrow \\ t \equiv x \\ \searrow \\ t \equiv x \end{matrix} \quad \begin{matrix} \text{(two-dimensional case)} \\ \text{(six-dimensional case)} \end{matrix}$$

As a consequence of eqs. (27), (27'), our SLT's — as given by eqs. (9), (10) — allow an interpretation which immediately generalizes to the case of generic (Superluminal) Lorentz transformations the meaning of Fig. 1 in Ref. (2) (notice that the meaning of that Fig. 1 was restricted in Ref. (2) to Superluminal Lorentz boosts). In other words, a generic SLT is obtained by operating the "dual" subluminal LT and then the rotation $(\vec{x}' \rightleftharpoons \vec{t}')$ (see eqs. (9), (10)).

Now, let us study the structure of the GLT's in the auxiliary space-time $[M_6]$ they all would actually be transformations, and not only mappings]. As always, the GLT's can be considered either from the active point of view (i.e. as operating on the observed phenomena: in other words, as "rotating" the observed chromoptical 6-vector in M_6) or from the passive point of view (i.e., keeping the 6-vector fixed and "rotating" the six axes without changing their names during the "rotation"). The previous Sections (cf. e.g. eqs. (27')) imply that we assume:

$$(28a) \quad \text{for } LT_6 \quad ds_6'^2 = + ds_6^2 ;$$

$$(28b) \quad \text{for } SLT_6 \quad ds_6'^2 = - ds_6^2 ,$$

with obvious meaning of the symbols.

At this point, let us explicitly notice that the subluminal LT's in M_6 — to be reducible in four dimensions to the ordinary ones in agreement with Special Relativity —, must be confined to those ones that call into play only one time-axis, let it be $t \equiv t_1$, while t_2, t_3 remain unchanged. Or rather, since in the 4-dimensional space (x, y, z, t) it must moreover be $ds_4'^2 = + ds_4^2$, the remaining time-axes may change in M_6 but only in such a way that (\vec{t}') :

(**) For simplicity, sometimes we indicate an axis and the corresponding coordinate by the same symbol.

$$(28'') \quad t_2'^2 + t_3'^2 = t_2^2 + t_3^2 \quad (LT)_6$$

As a consequence, because of eqs. (8)-(10), also the SLT's in M_6 must satisfy some constraints. For instance, from the passive point of view and with the adopted orientation of the 3-space $\{\vec{t}\}$, it happens that: 1) for a Superluminal boost along x , the axes t_1, x' rotate in the plane (x, t_1) , whilst $t_2 \rightleftharpoons y, y' \rightleftharpoons t_2$, and $t_3 \rightleftharpoons z, z' \rightleftharpoons t_3$; 2) for a Superluminal boost along y , the axes t_1, y' rotate in the plane (y, t_1) , whilst $t_2 \rightleftharpoons x, x' \rightleftharpoons t_2$, and $t_3 \rightleftharpoons z, z' \rightleftharpoons t_3$; 3) for a Superluminal boost along z , the axes t_1, z' rotate in the plane (z, t_1) , whilst $t_2 \rightleftharpoons x, x' \rightleftharpoons t_2$, and $t_3 \rightleftharpoons y, y' \rightleftharpoons t_3$. In such a way that, when the boost speed U tends to infinity, the axis $t \equiv t_1$ tends to coincide with the boost-axis x_1 and the axis x_1' with the axis $t_1 \equiv t_1$:

$$(29a) \quad U \rightarrow \infty \text{ along } x \quad \Rightarrow \quad t' \equiv x; \quad x' \equiv t$$

$$(29b) \quad U \rightarrow \infty \text{ along } y \quad \Rightarrow \quad t' \equiv y; \quad y' \equiv t$$

$$(29c) \quad U \rightarrow \infty \text{ along } z \quad \Rightarrow \quad t' \equiv z; \quad z' \equiv t$$

where symbols $x, y, z, t, x', y', z', t'$ represent the corresponding axes. Cf. Fig. 2b.



As far as the signature in M_6 is concerned, we can adopt two alternative conventions. The first choice is this: We can paint in blue (red) the axes called $t_j (x_j)$ by the initial observer s_0 , and state that the blue (red) coordinate squares must always be taken as positive (negative), for all observers, even when they are "rotated" so to span the region initially spanned by the opposite-colour axes. In other words, we can convene always to choose the metric (++++) for all frames $(t'_x, t'_y, t'_z, x', y', z')$, where the axis names — let us repeat — are here considered never to change during their "rotation". Under such assumptions, a transcendent SLT acts essentially as follows:

$$(30) \quad \left\{ \begin{array}{l} + \\ + \\ + \\ - \\ - \\ - \end{array} \right\} \left\{ \begin{array}{l} t_z \rightarrow t'_z = z \\ t_y \rightarrow t'_y = y \\ t_x \rightarrow t'_x = x \\ x \rightarrow x' = t_x \\ y \rightarrow y' = t_y \\ z \rightarrow z' = t_z \end{array} \right\} \quad \left[\text{under } S \right]$$

Notice that in eqs(30) no imaginary units enter.

The second choice would consist (still without changing name to the axes t'_j, x'_j during their "rotations") in adopting the opposite 6-dimensional metric in the r.h.s. of eqs.(30). This choice corresponds to changing the 'axis signatures' during their "rotations". In such a case we could formally write:

$$(31) \quad \left\{ \begin{array}{l} + \\ + \\ + \\ - \\ - \\ - \end{array} \right\} \left\{ \begin{array}{l} t_z \rightarrow it'_z = iz \\ t_y \rightarrow it'_y = iy \\ t_x \rightarrow it'_x = ix \\ x \rightarrow ix' = it'_x \\ y \rightarrow iy' = it'_y \\ z \rightarrow iz' = it'_z \end{array} \right\} \quad \left[\text{under } S \right]$$

Such a choice implies the appearing of imaginary units, whose significance however is here merely connected with the change of metric with respect to eqs.(30). Let us observe that the discussion at the beginning of this Section on the effects in M_6 of the transcendent transformation S was performed with the first metric-choice.

Of course, one can also adopt the Euclidean metric (cf. Sect.5); then, defining $X \equiv ix; Y \equiv iy; Z \equiv iz$, under a transcendent SLT one gets:

$$(32) \quad \left\{ \begin{array}{l} + \\ + \\ + \\ + \\ + \\ + \end{array} \right\} \left\{ \begin{array}{l} t_z \rightarrow t'_z = -iz \\ t_y \rightarrow t'_y = -iy \\ t_x \rightarrow t'_x = -ix \\ X \rightarrow X' = +it'_x \\ Y \rightarrow Y' = +it'_y \\ Z \rightarrow Z' = +it'_z \end{array} \right\} \quad \left[\text{under } S \right]$$

In any case, it is apparent that the axes called t'_x, t'_y, t'_z by the subluminal observer s_0 [i.e., considered by s_0 as subtending a 3-temporal space, since $(t'_x, t'_y, t'_z) \perp (x, y, z)$] are considered by the Superluminal observer S' , and by any other S' , as spatial axes [i.e., subtending a 3-spatial space]; and vice-versa. This essential point is important also for the following.

Let us remember, however, that M_6 for us is just an auxiliary space-time, and that our aim is being able to go back to four dimensions.

According to our Postulate 2) we have actually to assume that the initial observer s_0 has access only to a 4-dimensional slice M_4 of M_6 , in the sense that s_0 describes the kinematics of every object in the 4-dimensional space-time M_4 . When s_0 describes bradyons B , we have to assume that $M_4 \equiv (t_1 \equiv t; x, y, z)$, so that the coordinates t_2, t_3 of any bradyon are not observable by s_0 . With regard to Superluminal Lorentz transformations, we now must specify:

- (i) from the passive point of view, which is the "observability slice" (or "observation slice") M'_4 of M'_6 accessible to the Superluminal observer S' (when he describes his own bradyons);
- (ii) from the active point of view, which is the 4-dimensional space-time M'_4 of M'_6 accessible to s_0 for describing tachyons T .

By checking e.g. eqs.(30), we realize that only two choices are essentially

possible: 1) the "observability slice" M_4 is the 4-dimensional space-time (t'_x, x', y', z') ; or 2) the "observability slice" M_4 is the 4-dimensional space-time (t'_z, y', t'_x, x') .

For instance from the passive point of view the meaning of those choices is the following. The first choice corresponds to assume that each axis while rotating carries with itself the property of being observable or unobservable, so that the axes observable by S' are the transforms of the axes observable by S_0 . The second choice, on the contrary, corresponds to assume that the observability (or unobservability) of each axis is merely established by its position in M_6 (as judged by one and the same observer), so that two of the axes $[t'_x, y', t'_z]$ observable to S' are the transforms of two axes $[t, y', z]$ unobservable to S_0 . In other words, in M_6 , the first choice corresponds to assume $M_4 \perp M_4$, whilst the second choice corresponds to assume $M_4 \equiv M_4$ (in M_6 , when it is referred to one and the same observer): This is particularly evident in the case of a transcendent SLT. Roughly speaking, the abovementioned properties of the two choices get inverted when passing to the active point of view. Let us now examine the consequences of the two choices.

First choice: This choice would look more natural (especially from the active point of view). However, it does not lead automatically from the active invariance (except for its sign) in six dimensions, eq.(28b), to the ds_4^2 invariance (except for its sign) in four dimensions. Moreover, it actually calls all six coordinates into play, even in the case of the subluminal LT's obtained through a suitable chain of SLT's and LT's. In conclusion, this choice could be adopted only for building up a really 6-dimensional theory, a theory that (preferably) do not require that $ds_4^2 = - ds_4^2$. The resulting theory would be similar to Antippa's (18) in the sense that it would predict the existence in M_4 of a "tachyon corridor", and that it would violate in M_4 the light-speed invariance.

Second choice: This choice, once assumed for SLT's in M_6 that $ds_6^2 = - ds_6^2$, does lead automatically also to $ds_4^2 = - ds_4^2$ in four dimensions. Moreover,

it calls actually into play only four coordinates, in the sense that — in connection e.g. with eqs.(30) — it is enough to know initially the coordinates (t'_x, x', y', z) in M_4 in order to know finally the coordinates (t'_z, y', t'_x, x') in M_4 .

We adopt the Second choice, since we like here to be able to go back from six dimensions to four dimensions only, and since we like to have the light-speed invariance preserved (in the most natural way) even under SLT's in four dimensions. The "square brackets" appearing in eqs.(30)-(32) just refer to such a choice. We also start by adopting in the following the signature associated with eqs.(30).

If we consider in M_6 in particular a 6-vector \underline{v} lying on the slice $M_4(t \equiv t; x, y, z)$, then a SLT — regarded from the active point of view — will rotate \underline{v} in M_6 into a vector \underline{v}' lying on the slice $M_4(t'_x, y', t'_z; x')$, so as it is performed e.g. by the transcendent Lorentz transformation. According to our choice, this means that a bradyon B with coordinates $(t; x, y, z)$ in $M_4(1,3)$ will be transformed by a SLT into a tachyon T having in $M_4(3,1)$ the four coordinates (t'_x, t'_y, t'_z, x') , a priori all observable. Cf. Fig.3. It is noticeable, let us repeat, that any SLT, as given by eqs.(9)-(10), (18), leads — from an initial object with observable coordinates lying in the space-time $M(1,3) \equiv (t; x, y, z)$ — to a final object with "observable" coordinates lying in the space-time $M'(3,1) \equiv (t'_1, t'_2, t'_3; w)$, where the w-coordinate axis belongs to the 3-space $E(3) \equiv (x, y, z)$, and the t-coordinate axis belongs to the 3-space $E'(3) \equiv (t_1, t_2, t_3)$: See Fig.2a; formally: $(1,1)$

$$(28c) \quad (1,3) \xrightarrow{\text{SLT}} (3,1) .$$

We shall come back soon to this relation.

Let us pass to the passive point of view. Our choice corresponds to interpret the Postulate 2) as meaning that the initial observer S_0 has access e.g. only to the 4-dimensional slice $(t_x \equiv t; x, y, z)$, while the final observer S' , e.g. S'_∞ , has access only to the 4-dimensional slice (t'_z, y', t'_x, x') ; so that the coordinates t'_y, t'_z (and y', z') are not observable. (see the last two ref. (15)).

Three essential observations are in order.

First - As already mentioned, it is interesting that, from eq.(28b) in six dimensions

$$(28b) \quad t_z'^2 + t_y'^2 + t_x'^2 - x'^2 - y'^2 - z'^2 = - (t_z^2 + t_y^2 + t_x^2 - x^2 - y^2 - z^2), \quad [\text{SLT's}]$$

and from eqs.(30), it follows that in four dimensions:

$$(28') \quad \begin{cases} t_z'^2 + t_y'^2 + t_x'^2 - x'^2 = - (t_z^2 - x^2 - y^2 - z^2), \\ y'^2 + z'^2 = t_y^2 + t_z^2, \end{cases} \quad [\text{SLT's}]$$

so that:

$$(28d) \quad ds_4'^2 = - ds_4^2 \quad [\text{SLT's}]$$

where of course $ds_4'^2$ is evaluated in M_4' and ds_4^2 in M_4 .

Second - Let us recall that the axes called t'_z, t'_y, t'_x by the final observer S' (and deriving from the "rotation" of the axes t_z, t_y, t_x) are considered by the initial observer s_0 as space-axes; and so on. Let us recall, moreover, that —with our choice of the S' observability-slice— S' will have access to the axes (t'_z, t'_y, t'_x, x') , where x' comes from the "rotation" of the boost-axis. Now, our Postulate 2) requires —a priori— the final observer S' to consider

his space-time (t'_z, t'_y, t'_x, x') as related to three space-axes and one time-axis [actually renaming them, e.g., ξ_1, ξ_2, ξ_3 and τ' respectively]. This consideration constitutes the core of the interpretation of eqs.(8)-(10),(18), i.e. of the understanding of how the second observer S' sees the tachyons T in his M_4' .

Third - Another important consideration follows from Postulate 1) and the requested equivalence⁽⁴⁾ of all inertial frames. In fact: If we start from the description of the bradyon B (in M_4) by a subluminal observer s_0 , then a SLT brings of course to the description of a tachyon T (in M_4) by a Superluminal observer S' . The Principle of Relativity imposes that also s_0 describe tachyons (in his own M_4) so as S' describes tachyons (in M_4'); and, vice-versa, that also S' describe bradyons (in his own M_4') so as s_0 describes his bradyons (in M_4). It is evident that, once we understand how S' sees his tachyons in

M_4' , we shall be immediately be able to go back to the initial $M(1,3)$ and to forget about the auxiliary 6-dimensional $M(3,3)$.

In connection with M_4' , and still with the signature in eqs.(30), the effect of S will be the following

$$(30') \quad \begin{cases} \begin{pmatrix} + \\ + \\ + \\ - \end{pmatrix} \begin{matrix} t_z \rightarrow t'_z = z \\ t_y \rightarrow t'_y = y \\ t_x \rightarrow t'_x = x \\ x \rightarrow t'_x = t_x \end{matrix} \end{cases} \begin{pmatrix} + \\ + \\ + \\ - \end{pmatrix}$$

In the slightly more general case of a Superluminal boost along x , eqs.(30') would transform into

$$(33) \quad \begin{cases} \begin{pmatrix} + \\ + \\ + \\ - \end{pmatrix} \begin{matrix} t_z \rightarrow t'_z = z \\ t_y \rightarrow t'_y = y \\ t_x \rightarrow t'_x = \pm \frac{x-ut}{\sqrt{1-u^2}} \pm \frac{t-ux}{\sqrt{1-u^2}} \\ x \rightarrow x' = \pm \frac{x-ut}{\sqrt{1-u^2}} \pm \frac{t-ux}{\sqrt{1-u^2}} \end{matrix} \end{cases} \begin{pmatrix} + \\ + \\ + \\ - \end{pmatrix}$$

$$[U \equiv c^2/u \\ u^2 < c^2; \quad U^2 > c^2]$$

In eq.(33) no intervention of imaginaries appears; but our choice (30) implies that the Superluminal observer S' —from the metric point of view [since he uses the metric-signature (+++-)]— deals with the t'_i as if they were actual ly time-components, and with x' as if it were actually a space-component. In fact, choice (30) means that the coordinates taken on the axes t'_z, t'_y, t'_x are always to be considered by the primed observer as time-coordinates, even when "rotated" in M_6 beyond the six-dimensional light-cone (i.e., by S'); and analogously for x' .

We might say, as expected, that a tachyon T will appear in M_4' to S' (and therefore also to s_0 in M_4 , owing to the Relativity Principle) as represented by the same set of coordinates representing a bradyon B , provided that three out of those coordinates are regarded as time-coordinates, and only one as a space-coordi-

nate.

Since we do not understand the meaning of such a statement, we have to make recourse to some formal procedures, so to have apparently (formally) to deal always with three space-coordinates and one time-coordinate. One of the possible procedures is the following.

Let us change the signature-choice, by passing from eqs.(30) to eqs.(31), in such a way that both s_0 and S' use the signature $(+ - - -)$, as if even S' dealt with three space-coordinates and one time-coordinate. With choice (31), eqs.(33) transform into:

$$(33'') \quad \begin{pmatrix} - \\ - \\ - \\ + \end{pmatrix} \begin{cases} t \rightarrow t' = \pm iz; \\ y \rightarrow y' = \pm iy; \\ x \rightarrow x' = \pm i \frac{x-ut}{\sqrt{1-u^2}} = \pm i \frac{t-ux}{\sqrt{1-u^2}}; \\ x \rightarrow ix' = \pm i \frac{t-ux}{\sqrt{1-u^2}} = \pm i \frac{x-ut}{\sqrt{1-u^2}} \end{cases} \begin{pmatrix} - \\ - \\ - \\ + \end{pmatrix}$$

where now "imaginary units" do appear, which correspond to the metric change (30) \rightarrow (31). Eqs.(33'') are of course equivalent to eqs.(33).

Eqs.(33'') and therefore also eqs.(33), coincide with our eqs.(18), provided that one applies the second one of eqs.(27') to the vector $(it'_z, it'_y, it'_x, ix')$. We can now try to interpret eqs.(33''), and therefore eqs.(18).

Let us observe that the last two eqs.(33'') are true transformations between a couple of coordinates $[x, t]$ belonging to the initial observability slice and a couple of coordinates $[x', t']$ belonging to the final observability slice.

In other words, x' and t' come from the "rotation" of x and t , such a rotation always taking place inside the observability slice of both s_0 and S' . We can just eliminate the i 's on both sides, getting the reinterpreted equations

$$(34a) \quad \begin{pmatrix} + \\ - \\ - \\ - \end{pmatrix} \begin{cases} t' = \pm \frac{x-ut}{\sqrt{1-u^2}} = \pm \frac{t-ux}{\sqrt{1-u^2}}; \\ x' = \pm \frac{t-ux}{\sqrt{1-u^2}} = \pm \frac{x-ut}{\sqrt{1-u^2}}; \end{cases} \quad \left[\begin{array}{l} \text{Superluminal} \\ \text{boost} \end{array} \right]$$

if we started directly from the first two eqs.(18), it was enough—in order to get the same result—to apply to their r.h.s.'s the first one of eqs.(27') [i.e. to interpret i as a 90°-rotation operator in the two-dimensional space-time (x, t)].

Let us now observe that, on the contrary, the coordinates t'_y, t'_z —that S' must interpret to be his transversal space-coordinates ξ'_2, ξ'_3 —are the transforms of the initial coordinates t_y, t_z (unobservable to observer s_0), and not of the initial coordinates y, z . In other words, due to the structure of Superluminal boosts in M_6 , the axes ξ'_2, ξ'_3 derive by applying to the axes t_y, t_z a discrete operation which is a 90°-“rotation”, such a 90°-rotation taking place in M_6 outside the observability slices of s_0 and S' . As a consequence, differently from the procedure followed for the last two eqs.(33''), in the first two eqs.(33'') we have to substitute z' for it'_z and y' for it'_y , so that

$$(34b) \quad \begin{pmatrix} - \\ - \\ - \\ + \end{pmatrix} \begin{cases} z' = \pm iz; \\ y' = \pm iy, \end{cases} \quad \left[\begin{array}{l} \text{Superluminal} \\ \text{boost} \end{array} \right]$$

The i 's remain here: In fact the coordinates y', z' (considered as spatial by S') are considered as temporal by s_0 .

If we call, more generally, $t'_i \equiv \xi'_i$ and $t'_i \equiv i \xi'_i$ (with ξ'_2, ξ'_3 space coordinates, according to S'), then our approach—cf. eqs.(31) and (28'')—requires the transformed coordinates ξ'_2, ξ'_3 to satisfy the constraint:

$$(34c) \quad \xi'^2_2 + \xi'^2_3 = -(y'^2 + z'^2),$$

so as realized by relations

$$(34d) \quad \xi'_2 = \pm iy; \quad \xi'_3 = \pm iz.$$

But let us stress again that ξ'_2, ξ'_3 do not derive from the direct transformation of y, z . This must be born in mind even more carefully when—so as in eqs.(34b), or in eqs.(18) where only the quantities actually observable by s_0, S' enter—

we just call y', z' the axes ξ_2', ξ_3' , i.e. when the possibility of a confusion increases.

It is important to notice that our new eqs.(18) have been "reinterpreted" into eqs.(34a)-(34b), which coincide with the equations introduced by Mignani and Recami.⁽¹⁷⁾ That is to say, our new LT's just reduce to the "old" ones⁽¹⁷⁾ in the particular case of a Superluminal boost, —so as expected.

Before going on we want to underline again that an important point of our philosophy —following from our Postulates 1) and 2), and in particular from the equivalence of all observers— is that an observer s_0 associated with M_4 , will describe tachyons T exactly so as S' , associated with M_4 , describes his own tachyons. In a sense, we shall know how s_0 describes tachyons T only and if we succeed in mapping M_4 onto M_4 , so to "identify" M_4 and M_4 .

We have already seen that, from the passive point of view, $M_4 \equiv M_4$. We wanted to enforce, more generally, that every observer [either subluminal (M_4) or Superluminal (M_4)] sees the same, global Minkowski space-time and uses the same metric (+ - - -). The meaning of eqs.(34a)-(34b) is —as already stated in the first one of Refs.⁽¹⁹⁾— that (once a certain metric is chosen) any observer S' , which describes a particle P not through his own observations but through the observations on the same particle made by the dual (subluminal) observer s , has to manipulate those measurements not by the standard metric-signature but by the opposite one.

Let us summarize. In M_6 it is actually possible to introduce real Superluminal Lorentz transformations (cf. as a particular case eq.(30)). When passing to the "physical slices" M_4, M_4 and adopting Postulate 2), we can still confine ourselves to real SLT's, provided that we change signature passing from $s(+ - - -)$ to $S'(+ + + -)$. Alternatively, if we interpret Postulate 2) as requiring both s, S' to see a (Minkowskian) space-time with 3 space and 1 time axes and to use the same signature (+ - - -), then we have to introduce imaginary units, and end up with eqs.(33'), or with eqs.(18), i.e. with eqs.(34a)-(34b). The latter signature-choice, even if more tricky, is to be adopted, consistently with Postulate 2), since the former one would

imply to know a priori the meaning of «describing an object in M_4 by 3 time-coordinates and 1 space-coordinate», which is not —of course— our case. Conversely, we can hope to understand a posteriori that meaning via the latter choice.

Actually, we shall geometrico-physically interpret the significance of the imaginary transversal coordinates, at least in some important cases.

Z = SUPERLUMINAL BOOSTS IN TWO AND FOUR DIMENSIONS. THE FIRST STEP IN OUR INTERPRETATION PROCEDURE

Let us stick to the simple case of Superluminal boosts along x (in four dimensions). At the limit for $U \rightarrow \infty$, the transcendent Lorentz transformation (eq.(10)) yields:

$$(18') \quad t' = \pm it; \quad x' = \pm ix; \quad y' = \pm iy; \quad z' = \pm iz;$$

notice that any transcendent Lorentz transformation S can be expressed by eqs.(18) with $U \rightarrow \infty$.

From Section 6 it follows that both observers s, S' understand (and agree), in the case e.g. of a transcendent boost "along x", the relations $y' = \pm iy; z' = \pm iz$ to mean that —under the transcendent transformation S and from the passive point of view— the axes of space M_6 are interchanged as follows:

$$(30') \quad y \equiv t'_y \rightarrow t_y \equiv y'; \quad z \equiv t'_z \rightarrow t_z \equiv z',$$

apart from their signs; where $t'_y \perp t'_z; t'_y \perp y$ and $t'_z \perp t'_z; t'_z \perp z$. In the case of the first two eqs.(18'), however, both observers s, S' agree that for the axes $\underline{x}, \underline{t}, \underline{x}, \underline{t}$ it happens

$$t' \equiv x; \quad x' \equiv t.$$

always apart from their signs.⁽⁸⁾

⁽⁸⁾ Analogously, from the active point of view, the two Minkowski spaces M_4, M_4 intersect each other (in the auxiliary six-dimensional space) just along the plane $(x, t) \equiv (t', x')$. Cf. Figs.2 and Fig.3.

In conclusion, eqs. (18') can be (partially) "reinterpreted" by writing⁽¹⁹⁾

$$(18'') \quad t' = \pm x; \quad x' = \pm t; \quad y' = \pm iy; \quad z' = \pm iz.$$

After such a (partial) reinterpretation, one can say that a transcendent SLT along x operates —among the others— an exchange of the names attributed to the axes x, t . Let us observe that this physical reinterpretation follows by considering quantity \underline{i} as a rotation-operator⁽¹⁹⁾ in the complex plane $(x, t) \equiv (t', x')$, and not in the complex planes (y, t) or (z, t) . As a consequence, even if all transcendent Lorentz transformations (without rotations) S are formally identical and always expressed by eqs. (18'), they can nevertheless be subjected to different reinterpretations; so that —let us stress it— they actually differ from one another after the reinterpretation.⁽²⁰⁾

Let us consider now a generic Superluminal boost along x , eqs. (18), and recall that any SLT is the product of an ordinary subluminal LT by the transcendent Lorentz transformation S . The case in eqs. (18'), in other words, differs from the generic boost case for the fact that —before it— we have to apply a subluminal LT: cf. eqs. (18). Such a subluminal LT does not affect —in the case here considered— the coordinates y, z , so that for them the considerations related to eqs. (30'') hold unchanged. That LT acts in the plane (x, t) so that the global SLT is there represented by the first two eqs. (18):

$$(35) \quad \begin{cases} t' = \pm i \frac{t - ux}{\sqrt{1-u^2}}; \\ x' = \pm i \frac{x - ut}{\sqrt{1-u^2}}; \end{cases} \quad \left[\begin{array}{l} \text{Superluminal case;} \\ u^2 < c^2 \end{array} \right]$$

besides $y' = \pm iy; z' = \pm iz$.

In the 2-dimensional Minkowski space $M_2 \equiv (t, x)$ it is known that the axes corresponding to $\underline{\hat{t}} \equiv (t-ux)/\sqrt{1-u^2}$, $\underline{\hat{x}} \equiv (x-ut)/\sqrt{1-u^2}$ result to be "rotated" with respect to (t, x) by an angle α with $|\alpha| < 45^\circ$, in the sense that $\underline{\hat{x}}$ is rotated anti-clockwise and $\underline{\hat{t}}$ clockwise; whilst the remaining quantity \underline{i} represents⁽¹⁹⁾ the "rotation" by the angle $\alpha' = 90^\circ$. In the case of a more generic

⁽²⁰⁾ The reinterpretation procedure we are dealing with in this paper has nothing to do, of course, with the Stückelberg-Feynman-Sudarshan "Reinterpretation Principle" (RIP) also known as "Switching Principle".

SLT (without rotations) along a space-direction $\underline{\hat{x}}$, the plane M_2 in which \underline{i} operates as a $\frac{\pi}{2}$ -"rotation" will contain $\underline{\hat{t}}$ (instead of the x -axis).

In conclusion, eqs. (35) differ from the dual, ordinary LT's in that they geometrically represent in the M_2 space-time an analogous "rotation", augmented however by $\pm \frac{\pi}{2}$. This corresponds of course (with respect to the dual LT's) to the exchange of the roles of $\underline{\hat{x}}$ and $\underline{\hat{t}}$. In other words, after the present interpretation, eqs. (35) will write in four dimensions:

$$(36) \quad \begin{cases} t' = \pm \frac{x - ut}{\sqrt{1-u^2}} \equiv \mp \frac{t - ux}{\sqrt{u^2 - 1}}; \\ x' = \pm \frac{t - ux}{\sqrt{1-u^2}} \equiv \mp \frac{x - ut}{\sqrt{u^2 - 1}}; \\ y' = \pm iy; \\ z' = \pm iz, \end{cases} \quad \left[\begin{array}{l} \text{Superluminal case;} \\ u^2 < c^2; \quad u^2 > c^2 \\ U \equiv c^2/u \end{array} \right]$$

where, once more, we took advantage of the symmetry-property of ordinary LT's expressed by eqs. (19).

It is important to notice that eqs. (18) after their (partial) reinterpretation —i.e. eqs. (36)— do coincide with the equations by Mignani and Recami^(14,8).

The (reinterpreted) first two eqs. (36), in the 2-dimensional case, yield for the speed of the first frame S_0 relative to the second frame S' :

$$(37) \quad x = 0 \implies \frac{x'}{t'} = \pm \left(-\frac{1}{u}\right) = \mp U, \quad \left[U \equiv c^2/u \right]$$

where $u^2 < c^2$, and $U^2 > c^2$. This agrees with our initial eqs. (8). Notice that u, U are the speeds of the two dual frames $s \equiv s, s'$.

Actually, we could derive the "reinterpreted" form (36) in the 2-dimensional case from the original form (18) just by imposing the second frame S' to move relative to S_0 with the Superluminal speed $U = c^2/u$ (along x), as required by eqs. (8).

In the 4-dimensional case and for Superluminal boosts along x , in eqs. (37)

the expression $x = 0$ transforms into $\vec{x} = 0$, and u, U become the speeds (along the boost-direction: $\vec{u} // \vec{U}$) of the two dual frames s, s' . Then, eq.(37) eventually shows that our SLT's, eqs.(18), are actually associated to Superluminal motion, notwithstanding their appearance.

8 = VELOCITY AND FOUR-MOMENTUM OF TACHYONS IN FOUR DIMENSIONS

Let us refer to the four-dimensional case, and therefore to eqs.(36),(18). Eqs.(36) represent the initial eqs.(18) after their (partial) reinterpretation; the former and the latter have been written down for the particular case of a 4-dimensional boost along x . We have already stressed that our new SLT's coincide in this particular case —after their (partial) reinterpretation— with the ones proposed by Mignani and Recami¹⁺⁶.

However, our new SLT's do form now a group: Cf. eqs.(15)-(16).

We want to notice explicitly that, of course, our new SLT's form a group in their mathematical, original form (18), and not in the "reinterpreted" form (36). The reinterpretation, in fact, aims to clarify how each observer S' will rename the axes and therefore "physically interpret" his own observations. The reinterpretation (when necessary) is to be applied only at the end of any possible chain of GLT's; to act differently would mean to use diverse signatures (in our sense) during the procedure, and this is of course forbidden. Let us also recall the comments at the end of Sect.6 on the last two eqs.(36).

From eqs.(36) and (37) we have derived that, in the simple case of Superluminal boosts along x , the SLT's effect the transition from an observer s to observers s' moving relative to s with Superluminal speeds $U = c^2/u$, where u is the dual subluminal speed; in agreement with eqs.(8). More generally, if a subluminal LT carries from the rest-frame s_0 to a frame s endowed with velocity \vec{u} relative to s_0 , then the dual SLT must carry from s_0 to the frame S' endowed with velocity $U = u/x$; $U = u/u^2$; $U = u/u^2$; $U = u/u^2$, $[c=1]$, such that $U^2 = 1/u^2$.

Let us now consider —by making also recourse to what we called in Sect.6 the core of our "interpretation"— how the 3-velocity of an object (initially subluminal) transforms under the action of a Superluminal boost along x . By referring to the auxiliary space-time M_6 and to the names attributed to the axes by the initial observer s , the second observer S' is expected to define the 3-velocity of the observed object as follows

$$(39) \quad V'_x \equiv \frac{dt'_x}{dx}; \quad V'_y \equiv \frac{dt'_y}{dy}; \quad V'_z \equiv \frac{dt'_z}{dz}; \quad \left[\text{Superluminal boost} \right]$$

where the tilde indicates the transformation accomplished by the dual, subluminal LT (actually, $dt'_y \equiv dt_y$ and $dt'_z \equiv dt_z$); so that the tildes disappear when the considered SLT is a transcendent Lorentz boost:

$$(39') \quad V'_x \equiv \frac{dt}{dx}; \quad V'_y \equiv \frac{dt}{dy}; \quad V'_z \equiv \frac{dt}{dz}. \quad \left[\text{Transcendent boost} \right]$$

However, due to our Postulates, the Superluminal observer S' will of course define —in his own terminology— the 3-velocity of the observed object (tachyon) in the ordinary way:

$$(40) \quad v'_x \equiv \frac{dx'}{dt'}; \quad v'_y \equiv \frac{dy'}{dt'}; \quad v'_z \equiv \frac{dz'}{dt'}$$

where the primed quantities are a priori expressed by eqs.(18).

Identifying eqs.(40) with (39) on the basis of our previous Section [eqs.(36)] we get (cf. Fig.4):

$$(41) \quad v'_x \equiv \frac{dx'}{dt'} = \frac{dt'_x}{dx}; \quad v'_y \equiv \frac{dy'}{dt'} = \frac{dt'_y}{dy}; \quad v'_z \equiv \frac{dz'}{dt'} = \frac{dt'_z}{dz}$$

where, in the present case, $dy' = dy$; $dz' = dz$. Eqs.(41) justify once more passing from eqs.(18) to their "interpreted" form (36).

Namely, apart from the signs, our SLT's (see eqs.(37)) yield the final relations $[dt'_x \equiv dt]$:

$$(41'') \quad V'_x \equiv \frac{dx'}{dt'} = \frac{dt - u dx}{dx - u dt}; \quad V'_y \equiv \frac{dy'}{dt'} = i \frac{dy \sqrt{1-u^2}}{dx - u dt}; \quad V'_z \equiv \frac{dz'}{dt'} = i \frac{dz \sqrt{1-u^2}}{dx - u dt}$$

which relate the observations made by S on B to the observations made by S' on I (transform of B under the considered Superluminal boost). The imaginary units in the transverse-component numerators would a priori mean that the tachyonic object moves, with respect to the transformed observer S', with velocity \vec{V}' in the M_4 space-time: But we shall soon reinterpret this point, in connection with Refs. (6,21).

From eqs. (41') one immediately sees that

$$(42) \quad V'_x \vec{V}'_x = 1, \quad \text{and, in particular, } V'_x V'_x = 1 \text{ when } SLT = S.$$

Notice, therefore, that the dual correspondence $V'_x \neq c^2/v$ holds only for the velocity components along the SLT-direction (i.e., in our case, along x). That correspondence does not hold for the transverse components (even if, however, $V'_y \neq v_y; V'_z \neq v_z$), nor for the magnitudes V', \vec{V}' . In fact it is $[v^2, u^2 < 1; V \equiv |\vec{V}'|]$:

$$(43) \quad V'_x = \frac{1-uV_x}{V_x - u}; \quad V'_y = i \frac{V_y \sqrt{1-u^2}}{V_x - u}; \quad V'_z = i \frac{V_z \sqrt{1-u^2}}{V_x - u}$$

That is to say, the velocity transverse components V'_y, V'_z are connected with the longitudinal component V'_x in the same way as in the ordinary (subluminal) Special Relativity; let us recall that for the dual, subluminal LT one would have got $[v^2, u^2 < 1]$:

$$v_x = \frac{V_x - u}{1 - uV_x}; \quad v_y = \frac{V_y \sqrt{1-u^2}}{1 - uV_x}; \quad v_z = \frac{V_z \sqrt{1-u^2}}{1 - uV_x}; \quad \left[\frac{v}{V} < 1 \right]$$

(Remember also that quantities V'_i do not behave — of course — so as the spatial components of a 4-vector).

Eqs. (43), as well as eqs. (37), confirm that eqs. (18) are actually associated with Superluminal motion, notwithstanding their appearance (but in agreement with their form (36)).

By introducing, instead of the dual speed u , the speed $U \equiv c^2/u$ associated with the Superluminal Lorentz boost, eqs. (43) can be written $[U^2 > 1]$

$$(43') \quad V'_x = \frac{U - V_x}{UV_x - 1}; \quad V'_y = i \frac{V_y \sqrt{U^2 - 1}}{UV_x - 1}; \quad V'_z = i \frac{V_z \sqrt{U^2 - 1}}{UV_x - 1}$$

which — so as eqs. (43) — do express the velocity-composition law in the case of Superluminal boosts. (Notice, again, that V_y, V_z transform of course differently from y, z since they are not spatial components of a 4-vector).

It is important to observe that from eqs. (43), (43') one can verify that always (21)

$$(43'') \quad \vec{V}'^2 > 1,$$

even if $V'^2 \leq 0; V'^2 \leq 0$, so that $1 < \vec{V}'^2 \leq V'^2$: This means that $|\vec{V}'|$ is always real and Superluminal.

Moreover, from eqs. (43') one derives for the magnitudes the "Terletsky relation" $[\vec{U}] \equiv U]$

$$(44) \quad 1 - \vec{V}'^2 = \frac{(1 - \vec{V}^2)(1 - \vec{U}^2)}{(1 - \vec{U} \cdot \vec{V})^2}, \quad [V^2 < 1; \vec{U}^2, \vec{V}'^2 > 1]$$

which — by the way — has been shown elsewhere to be G-covariant.

Of course, one could get the same results in terms of four-velocities. Let us remember that the composition of the generic (subluminal) four-velocity V_μ with the (subluminal) x-boost four-velocity u_μ expresses:

$$\begin{cases} V'_0 = V_0 u_0 + V_1 u_1; \\ V'_1 = V_1 u_0 + V_0 u_1; \\ V'_{2,3} = V_{2,3} \end{cases}, \quad \left[\begin{matrix} V_\mu \\ V_\mu \end{matrix} \right] \begin{matrix} \mu \\ \mu \end{matrix} \begin{matrix} = +1; \\ = +1; \\ \text{subluminal boost} \end{matrix}$$

where the the boost-speed along x is $-u$. When V_μ is (still) subluminal but the x-boost velocity u_μ is Superluminal, since we are dealing with fourvectors we can apply our eqs. (18), (36) and get:

$$\begin{cases} V'_0 = V_1 u_0 + V_0 u_1 \equiv -(V_1 u_1 + V_0 u_0); \\ V'_1 = V_0 u_0 + V_1 u_1 \equiv -(V_0 u_1 + V_1 u_0); \\ V'_{2,3} = V_{2,3} \end{cases}, \quad \left[\begin{matrix} u \equiv 1/u; \\ \text{Superluminal boost} \end{matrix} \right] \begin{matrix} \mu \\ \mu \end{matrix} \begin{matrix} = +1; \\ = +1; \\ \text{subluminal boost} \end{matrix}$$

which ones do coincide with eqs.(43'). In these equations the x-boost Superluminal speed is $-U$, with $U \equiv 1/u$. Notice that, when applying the partially reinterpreted eqs.(36), one loses the group-properties. For such a reason, eqs.(43)-(43') should not be applied when starting from a Superluminal speed $|\vec{v}| > 1$.

As to the interpretation of the (imaginary) transverse components in eqs.(43), (43'), cf. Ref.(21). Here let us add the following. The 3-velocity \vec{W}' of the tachyon "barycenter"⁶, i.e. of the vertex of the "enveloping" cone (see Ref.(6) and Sect.9), must be, in any case, real. For example, in the trivial case when $v_z = v = 0$, it is simply $W'_x = W'_y = V'_x = V'_y$. More in general, when concerned with the overall velocity \vec{W}' of the considered tachyon, the imaginaries present in the transverse components of eqs.(43)-(43') essentially recall us the already mentioned fact that —by composing \vec{U} with \vec{v} — one gets a velocity \vec{V}' whose magnitude V' is smaller than V'_x . [Let us recall that V' is real, and always such that $V'^2 > 1$]. In the particular case when \vec{U}, \vec{v} are directed along x, y , respectively, and $|\vec{v}| < 1$, one may conclude that (cf. Fig.5):

$$(45) \quad |\vec{W}'| = \sqrt{U^2 - v^2} \equiv \sqrt{U^2 - \vec{v}^2}; \quad \text{tg } \alpha \equiv \frac{W'_y}{W'_x} = v \frac{\sqrt{U^2 - 1}}{U}, \quad [U \equiv |\vec{U}|]$$

which yield also the direction α of \vec{W}' . Notice that $W'_x = |\vec{W}'| \cos \alpha$; $W'_y = |\vec{W}'| \sin \alpha$, but $W'_x \neq V'_x$; $W'_y \neq V'_y$. The second one of eqs.(45) can be obtained on the basis of the following intuitive analysis.

Let us consider one reference-frame s_0 . Let us recall⁶ that, according to Refs.⁶, an (intrinsically) spherical object P, initially at rest w.r.t. s_0 and with its center C at the space origin O of s_0 , will appear to s_0 so as in Fig.6(d) [where, for simplicity, only the plane (x,y) is shown] when traveling along x with Superluminal speed $|\vec{W}'| \equiv W'_x$. It is trivial to extend the previous picture by saying that, when $C \neq O$, for instance $C \equiv (0, \vec{y})$, the shape of object P (if the laboratory which contains P travels again with speed W' parallelly to the x-axis) will be obtained simply by shifting by $\Delta y = \vec{y}$

along the y-axis the shape in Fig.6(d).

If P is now supposed to move slowly along y in the laboratory, and the laboratory travels parallelly to x with speed W' w.r.t. s_0 , it seems sensible to expect that the object P will appear to s_0 with a shape still similar to Fig.6(d), but travelling along a (real) line inclined with respect to the x-axis by an angle α .

In other words, the interpretation of the cone-vertex velocity (i.e. of the tachyon overall velocity) that we suggest —in accord with Refs.(6,21)— is shown in Fig.5. Let us consider for simplicity $V'_z = W'_z = 0$ and recall that the magnitude of the tachyon overall velocity is $W' \equiv |\vec{W}'| \equiv W_x'^2 + W_y'^2 = V_x'^2 - |V_y'|^2$, since $V'_y = i v \sqrt{U^2 - 1} / (U v_x)$ is imaginary. According to the interpretation of the imaginary transverse velocity-components here proposed, the direction of \vec{W}' is given by $\text{tg } \alpha \equiv W'_y / W'_x = (V'_y / i) / V'_x$. (See eq.(45)).

For different aspects of our interpretation, see Sections 5,6 in Ref.(21).

Now, let us apply the SLT's to fourmomentum². We define the fourmomentum in a G-covariant form as follows^{2,6,21}:

$$(46) \quad P_\mu \equiv m_0 \frac{v_\mu}{U}; \quad v_\mu \equiv dx_\mu / d\tau_0, \quad [v^2 \geq 1]$$

where the four-velocity v_μ is defined according to eq.(21). Then p_μ is a G-fourvector and we can apply to it transformations (18), or the (partially) reinterpreted transformations (36). Eqs.(36) yield for the tachyon-fourmomentum (obtained by applying a Superluminal boost along x to the case of a bradyon with 3-velocity \vec{v} ; $|\vec{v}| \equiv v < 1$):

$$(47) \quad \begin{cases} P_0^i = \pm \frac{p_0 - up_0}{\sqrt{1-u^2}} \equiv \pm \frac{p_0 - up_0}{\sqrt{U^2-1}}; \\ P_1^i = \pm \frac{p_0 - up_1}{\sqrt{1-u^2}} \equiv \pm \frac{p_1 - up_0}{\sqrt{U^2-1}}; \\ P_2^i = \pm i p_2; \quad P_3^i = \pm i p_3, \end{cases}$$

wherefrom, by the way, $P_{0,3}^i = \pm i m v_{0,3} \equiv \pm i m v_{0,y,z} / \sqrt{1-v^2} \equiv \pm i m v_{y,z}$.

Superluminal boost;
 $U^2 < 1; \quad v^2 \equiv v^2 < 1;$
 $U \equiv 1/u; \quad U^2 > 1$

Eqs. (47) can write:

$$\begin{cases} p_0 = \pm m \frac{V_X}{\sqrt{1-U^2}} \equiv \pm m \frac{1-UV_X}{\sqrt{1-U^2}} ; \\ p_1 = \pm m \frac{1-UV_X}{\sqrt{1-U^2}} \equiv \pm m \frac{V_X-U}{\sqrt{1-U^2}} ; \\ p_2 = m_0 V_2 = \pm i m V_Y = \pm i m_0 V_2 ; \\ p_3 = m_0 V_3 = \pm i m V_Z = \pm i m_0 V_3 . \end{cases} \quad \left[\text{Superluminal case} \right]$$

Notice that, even if these equations express the four-momentum of the final tachyon, nevertheless m and V_X, V_Y, V_Z represent the relativistic mass and the 3-velocity components of the initial bradyon (in the initial frame), respectively: in particular:

$$m \equiv \frac{m_0}{\sqrt{1-U^2}} \quad \left[V^2 \equiv V^2 < 1 \right]$$

The 3-velocity components V_X, V_Y, V_Z should not be confused with the 4-velocity components $V_\mu \equiv (V_0, V_1, V_2, V_3)$. Moreover, attention must be paid to the fact that V_μ refer to the initial bradyon (in the initial frame), while \vec{U} — and its dual velocity \vec{u} — refer to the SLT.

It is important to observe that, by comparing the four-momentum transformation law (47) with the velocity-composition law (43)-(43'), it follows even for tachyons to hold:

$$(48) \quad \begin{cases} p_0^i = \frac{m_0}{\sqrt{V'^2-1}} ; & p_1^i = \frac{m_0 V'_X}{\sqrt{V'^2-1}} ; \\ p_2^i = \frac{m_0 V'_Y}{\sqrt{V'^2-1}} ; & p_3^i = \frac{m_0 V'_Z}{\sqrt{V'^2-1}} . \end{cases} \quad \left[V'^2 \equiv V'^2 > 1 \right]$$

Notice that, since V'_Y and V'_Z are imaginary, quantities V_2^i and V_3^i are imaginary as well, in agreement with the fact that it is $V_2^i = \pm i V_2$; $V_3^i = \pm i V_3$.

At last, comparing eqs. (48) with eqs. (46), one derives that even in the tachyonic case the 4-velocity and the 3-velocity are connected as follows:

$$(49) \quad V^i = \frac{1}{\sqrt{V'^2-1}} ; \quad V^i = \frac{V'_X}{\sqrt{V'^2-1}} ; \quad V^i = \frac{V'_Y}{\sqrt{V'^2-1}} ; \quad V^i = \frac{V'_Z}{\sqrt{V'^2-1}} ,$$

where $V'^2 \equiv V'^2$. In conclusion, eqs. (46), (47), (48), (49), that we derived in the tachyonic case from eqs. (36), are self-consistent and constitute a natural extension of the corresponding subluminal formulae. For instance it is, in G-covariant form,

$$V_0^i = \left[\sqrt{1 - V'^2} \right]^{-1} ; \quad V_{1,2,3}^i = V_{X,Y,Z}^i \left[\sqrt{1 - V'^2} \right]^{-1} . \quad \left[V'^2 \geq 1 \right]$$

Since V_μ , so as X_μ and P_μ , is a G-fourvector (cf. eqs. (21) and (46)), we may apply the SLT's also directly to V_μ . By applying a Superluminal boost, one gets:

$$(50) \quad \begin{cases} V_0^i = \pm \frac{V_0 - UV_1}{\sqrt{U^2-1}} ; & V_1^i = \pm \frac{V_1 - UV_0}{\sqrt{U^2-1}} ; \\ V_{2,3}^i = \pm i V_{2,3} = \pm i \frac{V_{Y,Z}}{\sqrt{1-U^2}} . \end{cases} \quad \left[\begin{array}{l} \text{Tachyonic case;} \\ U^2 > 1 ; \quad V^2 < 1 \end{array} \right]$$

§ 9 = ON THE IMAGINARY TRANSVERSE COMPONENTS: THE SECOND STEP IN OUR INTERPRETATION PROCEDURE

In Sect. 7 we supplied a partial interpretation of eqs. (18), transforming them into eqs. (36). In order to complete their interpretation, we have to attribute a geometric-physical meaning also to their transverse components.

In fact, our interpretation of the SLT's, eqs. (18), has to proceed in two steps, which have been explained and formalized in Sect. 5 of our Ref. (21): See (21).

As to the application of SLT's in the chronotopical space, the presence of the $\langle\langle t's \rangle\rangle$ in the transverse components causes the shape of a tachyon (which be intrinsically spherical) to appear⁽⁶⁾ essentially so as in Fig. 6(d). Actually, if a bradyon P_B is infinitely extended in time, then by transforming its space-time shape under a SLT one gets a tachyon P_T whose space-extension is the whole (spatial) region confined between a double, unlimited cone C and a two-sheeted hyperboloid H (such a region travelling of course with Superluminal speed). If the life-time of P_B is, however, finite, then the space-extension

of P_T results to be finite too: Precisely, the shape of tachyon P_T in this case will be represented only by the (variable) portion of the above structure $C+H$ contained between two (spatial, two-dimensional) planes P_1, P_2 . Such a portion varies with time, since P_1, P_2 are mobile, and happen to travel at subluminal speed: See the last two quotations in Refs.⁽⁶⁾.

For further details as to the interpretation of the (imaginary) transverse components of eqs.(18),(36) —when applied in the chronotopical space— we refer here to all the papers listed under Ref.⁽⁶⁾.

As to the interpretation of the (imaginary) transverse components of the tachyon 3-velocity, —or, more in general, as to the case when SLT's are applied in the four-velocity and four-momentum spaces,— see Sect. 6 in Ref.⁽²¹⁾.

The particular case of the velocity of the C-cone vertex has been here discussed in Sect. 8.

Let us summarize. In Sects. 6-9 above:

- (i) We have seen how to pass from the initial Minkowski space-time M_4 , associated with the initial frame s , to the auxiliary space-time M_6 ; how to transform M_6 into itself ($M_6 \rightarrow M_6$) under a (six-dimensional) SLT; and then how to go back from M_6 to the final space-time M_4 , associated with the final frame s' . The possibility of going back from M_6 to M_4 is shown e.g. by the fact that the independent variables remain always four: For instance, under a transcendent SLT along x (when axis y' coincides with axis t_y , and z' with t_z), it results: $|t'_y| = |y'|$; $|t'_z| = |z'|$; even if: y' -axis $\perp t_y$ -axis $\perp t'_y$ -axis $\equiv y$ -axis and z' -axis $\perp t_z$ -axis $\perp t'_z$ -axis $\equiv z$ -axis.

(ii) Then, we interpreted how the final observer S' will describe the tachyons in his Minkowski space-time M'_4 (cf. Refs.⁽⁶⁾).

(iii) The Principle of Relativity imposes that both s and s' describe their own tachyons (or bradyons) in the same way. That is to say, the application

of a SLT both from the passive and from the active point of view must yield equivalent results. (Cf. also the first one of Refs.⁽⁴⁾). This allows, in a sense, to "identify" M'_4 and M_4 .

In other words, the interpretation mentioned under point (ii) —i.e. applied "under the passive point of view"— can be applied also "under the active point of view".

As a result, the "Lorentz" mappings (18) —after their interpretation, and essentially after the interpretation of their imaginary transverse components— can be regarded as (Lorentz, Superluminal) transformations. For this reason, always we just called Transformations our SLT's.

At last, let us recall⁽²¹⁾ that the four-dimensional SLT's in their original form are always purely imaginary, even when considering generic SLT's along generic motion-lines. To fix the ideas, let us consider a generic SLT "without rotations"⁽¹⁷⁾. Due to the space-rotation effect, it will appear to contain complex quantities only in its (partially) reinterpreted form; this trivial fact does not constitute any problem (cf. Sect. 5 in Ref.⁽²¹⁾), and its interpretation is related e.g. with Fig. 3 of Ref.⁽²¹⁾. Let us recall also (from our Sect. 8) that, in the case of a chain of GLT's, the interpretation procedure is to be applied only at the end of the chain.

ACKNOWLEDGEMENTS

The authors acknowledge continuous discussions with M. PAVSIC^V; and stimulating discussions with J. KOWALCZYŃSKI, P.-O. LÖWDIN, R. MIGNANI, B. MILEWSKI, D.M. PETRESCU, R. RĄCZKA, D. WILKINSIN; as well as useful discussions with A. AGODI, M. BALDO, A.O. BARUT, S.L. BAŻAŃSKI, H.R. BROWN, W.A. RODRIGUES Jr.. Thanks are moreover due to L.R. BALDINI for kind collaboration.

APPENDIX A

1 = Let us consider a space having (in a certain, initial base) the metric $g^{\mu\nu}$, so that for vectors x^α and tensors $M^{\alpha\beta}$ it is:

(A1a) $x^\alpha = g^{\alpha\beta} x_\beta$; $M^{\alpha\beta} = g^{\alpha\gamma} g^{\beta\delta} M_{\gamma\delta}$.

When passing to another base, one writes:

(A1b) $x^{\prime\mu} = g^{\prime\mu\nu} x'_\nu$; $M^{\prime\alpha}{}_\beta = g^{\prime\alpha\gamma} M_{\gamma\delta} y^\delta$.

In the two bases, the scalar products are defined

(A2) $x_\alpha x^\alpha \equiv x_\alpha g^{\alpha\beta} x_\beta$; $x'_\mu x^{\prime\mu} \equiv x'_\mu g^{\prime\mu\nu} x'_\nu$,

respectively.

Let us call A the transformation from the first to the second base, in the sense that

(A3) $x^{\prime\mu} = A^{\mu\rho} x^\rho$,

that is to say

(A4) $x^{\prime\mu} = (A^{-1})^\mu{}_\rho x^{\prime\rho}$.

Now, if we impose that

(A5) $x_\alpha x^\alpha = + x'_\mu x^{\prime\mu}$, [assumption]

we get:

(A6) $g_{\alpha\beta} = g^{\prime\mu}{}_\alpha A^{\mu}{}_\beta A^{\nu}{}_\beta$;

however, if we impose that

(A5') $x_\alpha x^\alpha = - x'_\mu x^{\prime\mu}$, [assumption]

we get that:

$$(A6') \quad g_{\alpha\beta} = -g'_{\mu\nu} A^\mu_\alpha A^\nu_\beta$$

and

2 = Let us consider the case (A5')-(A6), i.e.

$$(A5) \quad x_\alpha^\alpha = + x'^\mu_\mu \quad \text{[assumption]}$$

and let us look for the properties of transformations A which yield:

$$(A7) \quad g'_{\mu\nu} = + g_{\mu\nu} \quad \text{[assumption]}$$

It must be

$$(A6) \quad g_{\alpha\beta} = g'_{\mu\nu} A^\mu_\alpha A^\nu_\beta \quad \text{i.e.,} \quad g_{\alpha\beta} = A^\mu_\alpha A^\nu_\beta$$

wherefrom

$$(A8) \quad g^{\gamma\alpha} g_{\alpha\beta} = g^{\gamma\mu} A^\mu_\alpha A^\nu_\beta = A^{\mu\gamma} A_{\mu\beta} = (A^T)^{\gamma\mu} A_{\mu\beta}$$

At this point, if we impose that in the initial base

$$(A9) \quad g_{\mu\nu} \equiv \eta_{\mu\nu} \quad \text{[assumption]}$$

then eq.(A8) yields:

$$\delta^\gamma_\beta = (A^T)^\gamma_\mu A_{\mu\beta} = g^{\mu\kappa} (A^T)^\gamma_\kappa g_{\mu\alpha} A^\alpha_\beta = \delta^\kappa_\sigma (A^T)^\gamma_\kappa A^\sigma_\beta = (A^T)^\gamma_\kappa A^\kappa_\beta$$

that is to say

$$(A10) \quad (A^T)(A) = \mathbb{I}$$

and

3 = Now, in the case (A5')-(A6'), i.e.

$$(A5') \quad x_\alpha^\alpha = - x'^\mu_\mu \quad \text{[assumption]}$$

when

$$(A6') \quad g_{\alpha\beta} = -g'_{\mu\nu} A^\mu_\alpha A^\nu_\beta$$

let us investigate which are the properties of transformations A that yield

$$(A7') \quad g'_{\mu\nu} = -g_{\mu\nu} \quad \text{[assumption]}$$

In the particular case, again, when

$$(A9) \quad g_{\mu\nu} \equiv \eta_{\mu\nu} \quad \text{[assumption]}$$

it must be

$$g_{\alpha\beta} = -(-g'_{\mu\nu}) A^\mu_\alpha A^\nu_\beta$$

i.e. transformations A must still be orthogonal:

$$(A10) \quad (A^T)(A) = \mathbb{I}$$

In conclusion, transformations A when orthogonal operate in such a way that:

$$(A11) \quad \begin{cases} \text{(i) either} & x_\alpha^\alpha = + x'^\mu_\mu \quad \text{and} \quad g'_{\mu\nu} = + g_{\mu\nu} \\ \text{(ii) or} & x_\alpha^\alpha = - x'^\mu_\mu \quad \text{and} \quad g'_{\mu\nu} = - g_{\mu\nu} \end{cases}$$

4 = On the contrary, let us now require that

$$(A5'') \quad x_\alpha^\alpha = - x'^\mu_\mu \quad \text{[assumption]}$$

when

$$(A6'') \quad g_{\alpha\beta} = -g'_{\mu\nu} A^\mu_\alpha A^\nu_\beta$$

and simultaneously let us look for the transformations A such that

$$(A7) \quad g'_{\mu\nu} = + g_{\mu\nu} \quad \left[\text{assumption} \right]$$

In this case, when in particular assumption (A9) holds, $g_{\mu\nu} \equiv \eta_{\mu\nu}$, we get that transformations A must be anti-orthogonal

$$(A12) \quad (A^{-1})(A) = - \mathbb{1}$$

$$A \quad A \quad A$$

5 = The same result (A12) is easily obtained when assumptions (A5) and (A7') hold, together with condition (A9).

In conclusion, transformations A when anti-orthogonal operate in such a way that:

$$(A13) \quad \begin{cases} (i) & \text{either } x_{\alpha}^{\alpha} x^{\alpha}_{\mu} = - x^{\alpha}_{\mu} x^{\mu}_{\alpha} & \text{and } g'_{\mu\nu} \equiv + \eta_{\mu\nu} \\ (ii) & \text{or } x^{\alpha}_{\mu} x^{\mu}_{\alpha} = + x^{\alpha}_{\mu} x^{\mu}_{\alpha} & \text{and } g'_{\mu\nu} \equiv - \eta_{\mu\nu} \end{cases}$$

Our conclusions (A11) and (A13) show once more that, when passing from subluminal to Superluminal frames, one must impose a sign-change either in the quadratic form, eq.(A5'), or in the metric, eq.(A7'), but not in both (otherwise one would merely get an ordinary transformation $s \rightarrow s'$, or $S \rightarrow S'$, and not a Superluminal transformation $s \neq S'$). (2.11)

Let us add the following comment. The pseudo-Euclidean Minkowski space being a particular Riemannian space, one could remember the theorems of Riemannian geometry (theorems standard in General Relativity), which state that the quadratic norm is positive definite and that the $g_{\mu\nu}$ -signature is invariant, and therefore wonder how it can be possible for our anti-orthogonal transformations to act in a different, opposite manner. To answer, we may recall that the anti-orthogonal transformations do not belong to the group of the "arbitrary" coordinate-transformations usually adopted in General Relativity: see Ref.(22).

=====
FIGURE CAPTIONS
=====

Fig.1 - Where we show the effect of the different GLT's, when starting from P. It is: $\mathcal{L}_{I} \equiv (+1) \cdot \mathcal{L}_{+}^{\uparrow}$; $\mathcal{L}_{II} \equiv (-1) \cdot \mathcal{L}_{+}^{\uparrow}$; $\mathcal{L}_{III} \equiv (+1) \cdot \mathcal{L}_{+}^{\uparrow}$; $\mathcal{L}_{IV} \equiv (-1) \cdot \mathcal{L}_{+}^{\uparrow}$.

Figs.2 - Fig.(a): The auxiliary six-dimensional space-time M(3,3), as described by one and the same (six-dimensional) observer, temporarily used to interpret the SLT's. A transcendent transformation, $S \equiv \pm i\mathbb{1}$, carries E(3) \neq E'(3). Fig.(b): Starting from M(3,3), referred to a subluminal observer s, we can choose the axes t, x, y, z in such a way that any transcendent SLT (without rotations (16)) S operates so as in this picture. Actually, it is $S = \pm i\mathbb{1}$. The figure (generalizing what happens in the two-dimensional case for the space-time (x,t)) shows that —and how— the imaginary unit i operates as a 90°-rotation operator in our auxiliary, 3-temporal space-time. Such a significance of quantity i is analogous to its meaning in ordinary SR, where it distinguishes the time-coordinate from the space-coordinates.

Fig.3 - In the auxiliary space M_6 , the two Minkowski spaces M_4, M'_4 (representing the four-dimensional slices associated e.g. with a bradyon B at rest and with a transcendent tachyon T, respectively) intersect each other along the plane $(x,t) \equiv (t',x')$: of course, the axes $x \equiv t'$ and $t \equiv x'$ in reality are not collinear. This holds when everything is described by one and the same (six-dimensional) observer, i.e. when the 6-dimensional GLT's are regarded from the active point of view.

Fig.4 - It is shown the effect in M_6 of a subluminal Lorentz boost along x (see the text).

Fig.5 - Let us notice that, in the simple case when $V'_z = W'_z = 0$, for the mag-

nitide $W' \equiv |\vec{W}'|$ of the tachyon overall velocity is $W'^2 \equiv W'_x{}^2 + W'_y{}^2 = V'^2 - |V'_y|^2$, since $V'_y = i v_y \sqrt{0^2 - 1} / (Uv_x - 1)$ is imaginary. According to the interpretation here suggested for the velocity imaginary transverse components, the direction α of \vec{W}' is given by $\tan \alpha \equiv W'_y / W'_x = (V'_y / i) / V'_x$ (see eq.(45) of the text). The hyperbola depicts the relation $\vec{V}'^2 = V'^2 - |V'_y|^2$.

Figs.6 - If a particle is intrinsically spherical, i.e. it is a sphere in its rest frame (fig.(a)), then under a subluminal x-boost it will become ellipsoidal (fig.(b)), as well known; and under a Superluminal x-boost it will become so as in fig.(d). Fig.(c) refers to the limiting situation when $u \rightarrow c$. For simplicity, we skipped the z-axis. Cf. also the text.

REFERENCES

- 1) E.RECAMI and R.MIGNANI: Lett.Nuovo Cimento 4,144(1972), and references therein. See also M.PAVSIC: "The Extended Special Theory of Relativity", preprint (Univ. of Ljubljana, 1971), unpublished.
- 2) E.RECAMI and R.MIGNANI: Rivista Nuovo Cimento 4, 209÷290,398(1974), and references therein. See also Lett.Nuovo Cim.8,110(1973).
- 3) E.RECAMI: in Tachyons, monopoles, and Related Topics, ed. by E.Recamì (North-Holland; Amsterdam,1978), p.3. See also H.C.CORBEN: Nuovo Cimento A29,415(1975).
- 4) E.RECAMI and W.A.RODRIGUES: Found. of Phys.12,709(1982); G.D.MACCARRONE and E.RECAMI: Lett.Nuovo Cimento 34,251(1982); E.RECAMI: chapt.16 in A.Einstein 1879-1979: Relativity, Quanta and Cosmology in the development of the scientific thought of Albert Einstein, ed. by F. de Finis (Johnson Rep. Co.; New York, N.Y.,1979), vol.2, p.537÷597; E.RECAMI: chapt.18 in Astrofisica e Cosmologia, Gravitazione, Quanti e Relatività nello sviluppo del pensiero scientifico di Albert Einstein, ed. by M.Pantaleo (Giunti-Barbera; Florence, 1979), p.1021÷1097.
- 5) P.CALDIROLA and E.RECAMI: in Italian Studies in the Philosophy of Science, ed. by M. Dalla Chiara (Reidel; Boston and Dordrecht, 1980), p.249÷298.
- 6) E.RECAMI and G.D.MACCARRONE: Lett.Nuovo Cimento 28,151(1980); P.CALDIROLA, G.D.MACCARRONE and E.RECAMI: Lett.Nuovo Cimento 29,241(1980); A.O.BARUT, G.D.MACCARRONE and E.RECAMI: Nuovo Cimento A (in press); E.RECAMI: "Are Classical Tachyons Subluminal Quantum Objects?", Boll.Circolo Matem.Palermo (to appear).
- 7) See e.g. eq.(8) in Ref.⁽²⁾; eq.(14) in Ref.⁽³⁾; eq.(22) in Ref.⁽⁴⁾; eq.(14) in Ref.⁽⁵⁾; eqs.(1)-(2) in the first two references⁽⁶⁾.
- 8) C.SOMIGLIANA: Rendic.Accad.Naz.Lincei (Roma) 31,53(1922); Memorie Scelte (Torino, 1936), p.469; W.RINDLER: Special Relativity (Edinburgh,1966), p.16; L.PARKER: Phys.Rev. 188,2287(1969).
- 9) See e.g. M.T.TELI and V.K.SUTAR: Lett.Nuovo Cimento 21,127(1978); M.T.TELI: Lett.Nuovo Cimento 22,489(1978).
- 10) V.GORINI: Comm.Math.Phys.21,150(1971), and references therein.

- 11) Cf. e.g. R.MIGNANI and E.RECAMI: Lett.Nuovo Cimento 9,357(1974): See also K.T.SHAH: Lett.Nuovo Cimento 18,156(1971).
- 12) H.MINKOWSKI: "Space and Time", address delivered at the 80th Assembly of German Scientists and Physicians (Cologne, 21 Sept. 1908).
- 13) E.TONITTI: On the Formal Structure of Physical Theories (CNR; Milano, 1975), p.243; and references therein.
- 14) R.MIGNANI and E.RECAMI: Lett.Nuovo Cimento 16,449(1976); G.D.MACCARRONE and E.RECAMI: Lett.Nuovo Cimento 34,251(1982). See also M.BUNGE: Brit. Journ.Phil.Sc.9,39(1959); J.DORLING:Am.Journ.Phys.38,339(1970); N.KALITZIN: Multitemporal Theory of Relativity (Bulgarian Acad. of Sc.; Sofia, 1975); P.DEMERS: Cand.Journ.Phys.53,1687(1975).
- 15) P.T.PAPPAS: submitted to Int.Journ.Theor.Phys.(1976); E.A.B.COLE: Nuovo Cimento B44,157(1978); G.DATTOLI and R.MIGNANI: Lett.Nuovo Cimento 22,65(1978); V.VYSIN: Lett.Nuovo Cimento 22,76(1978); P.T.PAPPAS: Lett.Nuovo Cimento 22,601(1978); 29,429(1979); G.ZIINO: Lett.Nuovo Cimento 24,171(1979); J.STRNAD: Lett.Nuovo Cimento 25,73(1979); 26,535(1979); Journ.Phys.A13,L 389(1980); E.A.COLE: Phys.Letters A75,29(1979); Journ.Phys.A13,109(1980); Nuovo Cimento B55,269(1980); Phys.Letters A76,371(1980); Lett.Nuovo Cimento 28,171(1980); Nuovo Cimento A60,1(1980); M.PAVSIC: Lett.Nuovo Cimento 30,111(1981); Journ.Phys.A14,3217(1981); G.ZIINO: (submitted for publication); P.T.PAPPAS: Nuovo Cimento B68,111(1982); C.E.PATTY: Nuovo Cimento B70,65(1982). See also E.TONITTI: Appl.Math.Modelling 1,37(1976); B.JANCWICZ: "Electromagnetism with use of bivectors" (WrocZaw, 1980), unpublished; C.P.POOLE, H.A.FARACH and Y.AHARONOV: Found. of Phys.10,531(1980); G.SORCZYK: Acta Phys.Polonica B12,407(1981).
- 16) R.MIGNANI and E.RECAMI: Nuovo Cimento A30,533(1975); B21,210(1974).
- 17) See e.g. C.MØLLER: The Theory of Relativity (Oxford Univ.Press; Oxford, 1962), Sects. 18÷22, 45-46.
- 18) See e.g. A.F.ANTIPPA: Phys.Rev.D11,724(1975).
- 19) See R.MIGNANI and E.RECAMI: Lett.Nuovo Cimento 9,357(1974); A.RACHMAN and R.DUTHEL: Lett.Nuovo Cimento 8,611(1973); p.613; S.MARANAN: Lett.Nuovo Cimento 3,623(1972), p.626. Cf. also H.D.FRONING, Jr.: (to appear).
- 20) L.LANDAU and E.LIFSHITZ: Theorie du Champ (MIR; Moscow, 1966), p.19.
- 21) G.D.MACCARRONE, M.PAVSIC and E.RECAMI: Nuovo Cimento B (in press).
- 22) See e.g. C.MØLLER: The Theory of Relativity (Oxford Univ.Press.; Oxford, 1962), p.234.

J. Ferraro

UNIVERSITÀ - CATANIA
ISTITUTO DI FISICA
C.A.F.N. 95M
M.F.N. 5M.C.T.

DISGNO
N. 8518

DATA
26.6.1971

MACCARRONE & RECAHI I

Fig. 2 -

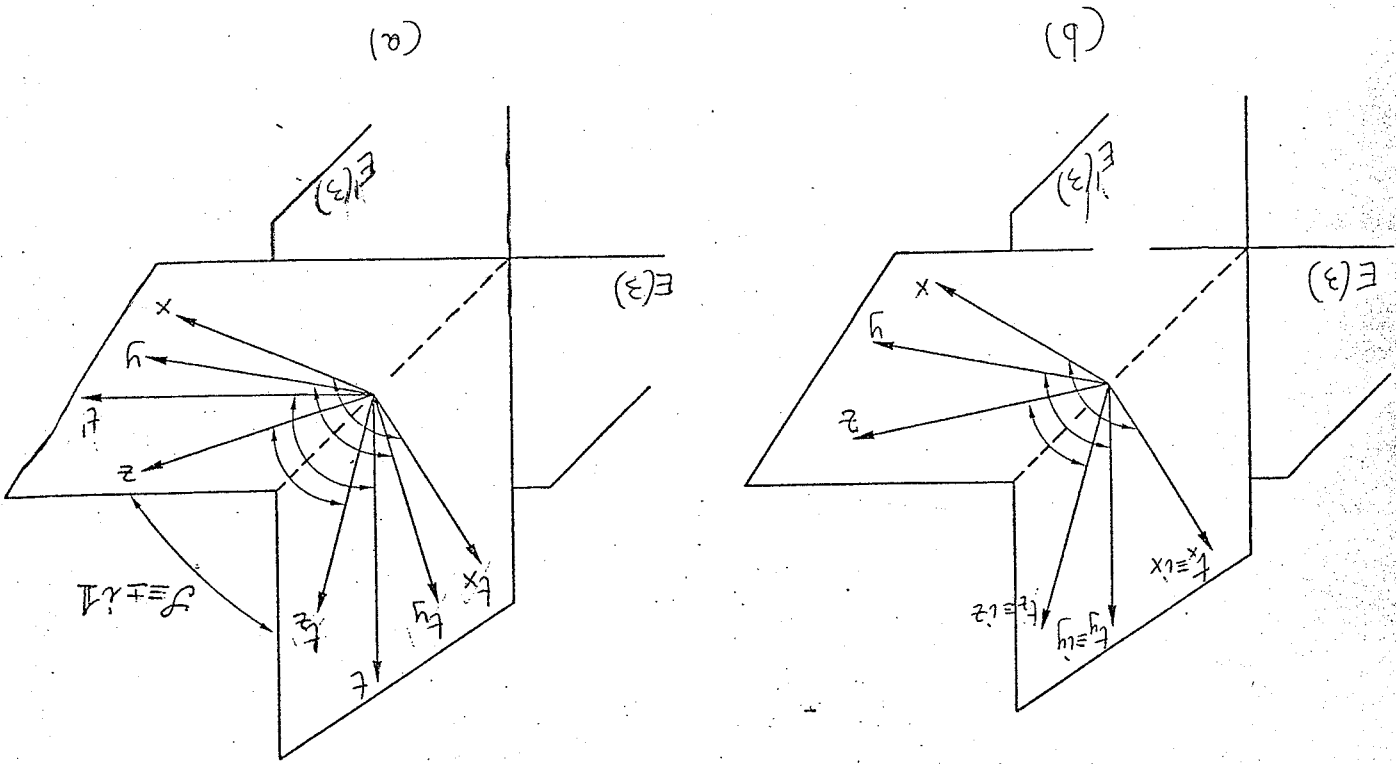

-51-

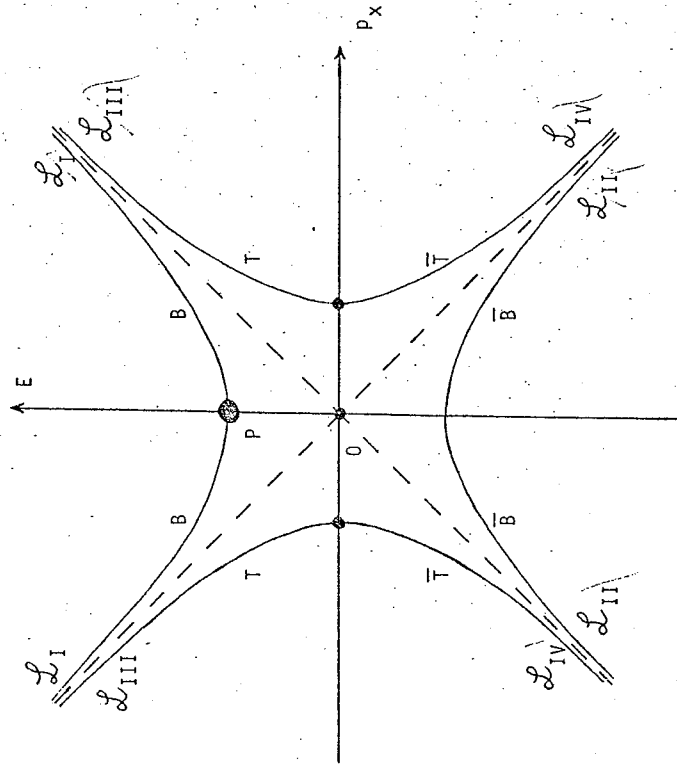
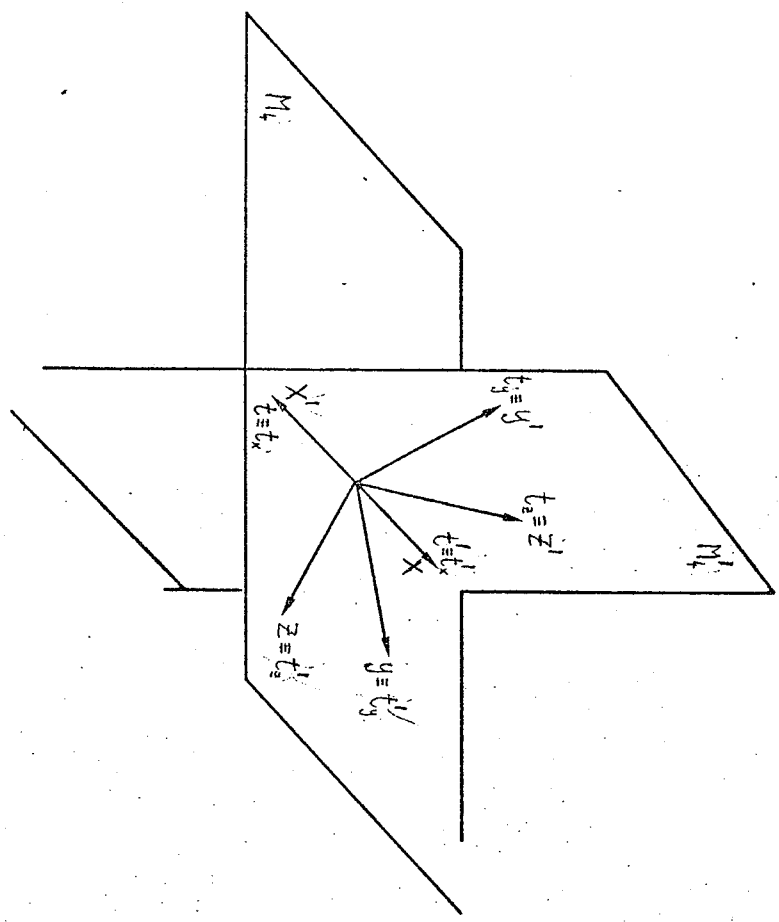

Fig. 1 -

-50-

MACCARRONE & RECAHI



- Fig. 3 -

MACCARRONE & RECAMI

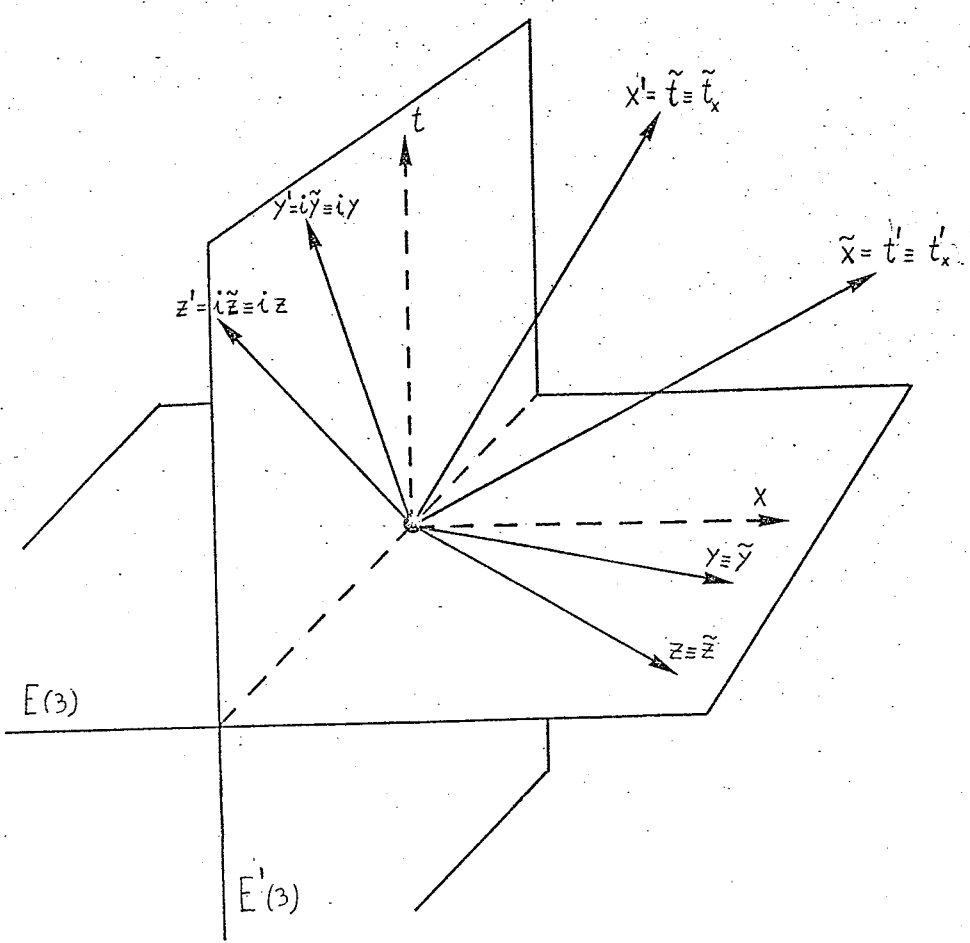

- Fig. 4 -

MACCARRONE & RECAMI

Fig. 6

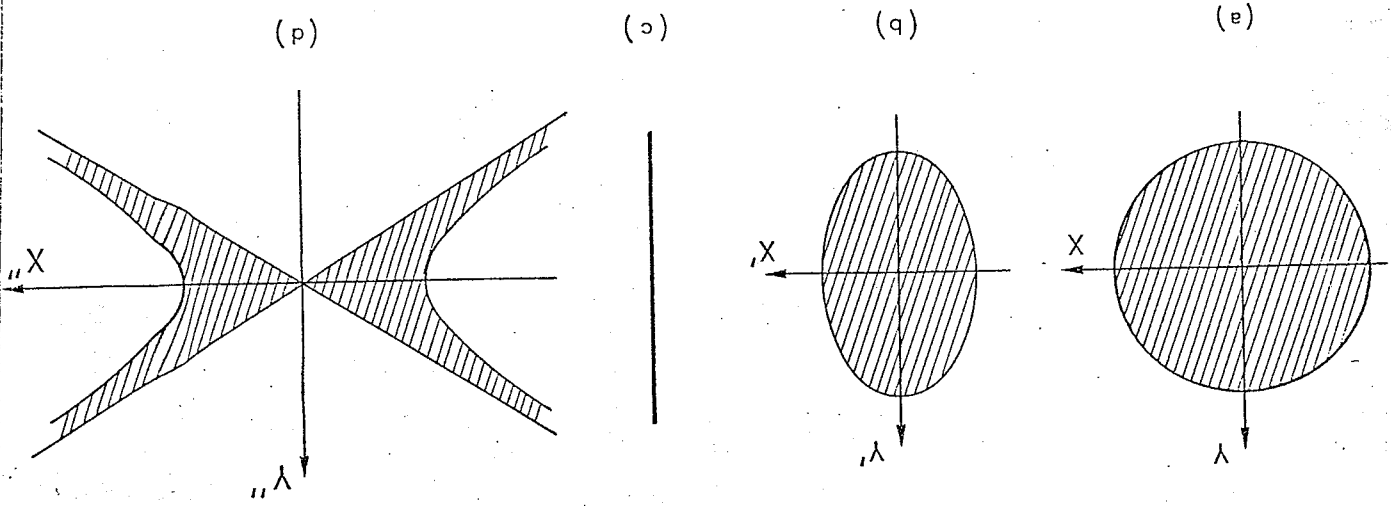

- Fig. 5 -

