

Thermodynamically Reversible Processes in Statistical Physics

Extended Version

Includes an appendix not in the journal version on processes with a Brownian particle.

John D. Norton

*Department of History and Philosophy of Science, University of Pittsburgh, Pittsburgh,
PA 15222*

(Dated: June 15, 2016)

Equilibrium states are used as limit states to define thermodynamically reversible processes. When these processes are implemented in statistical physics, these limit states become unstable and can change with time, due to thermal fluctuations. For macroscopic systems, the changes are insignificant on ordinary time scales and what little there is can be suppressed by macroscopically negligible, entropy-creating dissipation. For systems of molecular sizes, the changes are large on short time scales and can only sometimes be suppressed with significant entropy-creating dissipation. As a result, at molecular scales, thermodynamically reversible processes are impossible in principle. Unlike the macroscopic case, they cannot be realized even approximately, when we account for all sources of dissipation.

I. INTRODUCTION

In ordinary thermodynamics, a reversible process is, loosely speaking, one whose driving forces are so delicately balanced around equilibrium that only a very slight disturbance to them can lead the process to reverse direction. Since the process is arbitrarily close to a perfect balance of driving forces, they proceed arbitrarily slowly while their states remain arbitrarily close to equilibrium states. They can never become equilibrium states. For otherwise, there would be no imbalance of driving forces, no change and no process. Equilibrium states remain as they are.

This circumstance changes when we allow that thermal systems consist of very many interacting components, such as molecules, whose behavior is to be analyzed statistically. Then what were the limiting equilibrium states of ordinary thermodynamics are no longer unchanging. Molecular scale thermal fluctuations, that is, thermal noise, move them to neighboring states and, since there are no directed imbalances of driving forces, these migrations meander indifferently in a random walk. The very slight imbalance of forces of a reversible process must overcome this meandering if the process is to complete.

On macroscopic scales, the fluctuation-derived meandering is negligible and what little there is can easily be overcome by very slight imbalances in the driving forces. On molecular scales, however, fluctuations are large and significant imbalances in the driving forces are needed to bring any process to completion. Since such imbalances are dissipative, creating entropy, reversible processes are impossible on molecular scales. Completion of a process is only assured probabilistically, with higher probabilities requiring greater entropy creation.

The principal goal of this paper is to demonstrate these last claims at the general level and to provide an illustration of them in the isothermal expansion of an ideal gas. Section II introduces the essential but neglected idea that one cannot properly assess the dissipation associated with a process unless one accounts for all sources of dissipation. For reversible processes, that includes the normally suppressed devices that guide the process in its slow advance. Section III contains the main results for the cases of processes in both isolated and in isothermal systems. These results are illustrated in Section IV with the case of an isothermal expansion of an ideal gas.

II. SELF-CONTAINED THERMODYNAMICALLY REVERSIBLE PROCESSES

If our treatment of thermodynamically reversible processes is to be consistent, then we must consider the thermal and statistical properties of all the components involved in the process. This may seem like a minor point. However fully implementing it is essential to all that follows. A full implementation is rare since many common goals can be met without it. We may merely wish, for example, to determine the thermodynamic properties of some system, such as the volume dependence of the entropy of a gas. Then we can take shortcuts.

In a common case of the shortcut, the gas is confined to a cylinder under a weighted piston; and the entirety of the system is within a heat bath that maintains all components at a

fixed temperature T . Following a familiar textbook treatment,¹ the piston is weighted by a pile of sand whose mass is just enough to balance the gas pressure. No process will ensue, unless something changes. Tiny grains of sand are removed, one by one, successively lightening the load on the piston. With each removal, the gas expands slightly and the gas pressure drops slightly, until the pressure is once again balanced by the slightly less weighty piston. Repeated removals realizes a thermodynamically reversible expansion of the confined gas. The entropy change in the gas ΔS can now be determined by tracking the heat Q_{rev} gained by the gas, according to the Clausius formula $\Delta S = \int dQ_{\text{rev}}/T$.

In common treatments of thermodynamically reversible processes in statistical physics, all details of the machinery that slowly carries the process forward are omitted. In its place is the abstract notion of the manipulation of a variable, such as the volume of the expanding gas. The variable may be identified as an “external parameter” whose manipulation comprises a “switching process”;² or as a “control parameter” that is “controlled by an external agent.”³

In assuming that the external agent can slowly advance the control parameter, these reduced treatments neglect dissipation in the physical processes implementing the external manipulation. It is assumed tacitly, for example, that the mechanism that lightens the load on the piston can be implemented in some reversible, non-dissipative manner that is consistent with the fuller thermodynamic and statistical theory.

In principle, an explicit determination of compatibility of the process with our fuller theory would require examinations of the details of the external agent’s physical processes. Just what are the details of the non-dissipative machinery that picks off the sand grains one at a time? Only then have we shown that the process is theoretically self-contained, that is, relies only on the components manifestly conforming to our thermodynamic and statistical theory.

For macroscopic systems, neglecting these details is usually benign, especially if our concern is merely computing thermodynamic properties. The need to attend to these details becomes acute when we investigate processes on molecular scales. For fluctuations within molecular scale machinery are large and can disrupt the intended operation. As we shall see below, entropy creating disequilibria are required to overcome the fluctuations and bring any process in a molecular scale device to completion.

The discussion that follows is limited to self-contained thermodynamically reversible processes, since these are the only processes fully licensed by thermodynamic and statistical theory.

III. THERMODYNAMICALLY REVERSIBLE PROCESSES: GENERAL RESULTS

III.1 Limit States in Ordinary Thermodynamics

In ordinary thermodynamics, a thermodynamically reversible process is one whose states come arbitrarily close to limiting equilibrium states. For isolated systems, the equilibrium states approached have constant thermodynamic entropy. That is, if the stages of the process are parametrized by λ , proceeding from an initial value λ_{init} to a final value λ_{fin} , we have for the total entropy S_{tot} of the total system “tot” that

$$dS_{\text{tot}}/d\lambda = 0 \quad \text{and} \quad S_{\text{tot}}(\lambda_{\text{init}}) = \dots = S_{\text{tot}}(\lambda) = \dots = S_{\text{tot}}(\lambda_{\text{fin}}). \quad (1)$$

An important special case is an isothermal reversible process, where the subsystem “sys” is maintained as a constant temperature T by heat exchange with a heat bath environment “env,” with which it exchanges no work. For this process, the constancy of total entropy Eq. (1) is equivalent to the constancy of the free energy $F = U - TS$ of the system, where U is internal energy:⁴

$$dF_{\text{sys}}/d\lambda = 0 \quad \text{and} \quad F_{\text{sys}}(\lambda_{\text{init}}) = \dots = F_{\text{sys}}(\lambda) = \dots = F_{\text{sys}}(\lambda_{\text{fin}}). \quad (2)$$

A generalized force X and associated displacement variable x are defined so that the amount of work done dW by the system in a small constant temperature change is $dW = Xdx$. If X is the total generalized force and we use the displacement variable x to track the degree of completion of the process, so that $x = \lambda$, then X is given by⁵

$$X = - \left. \frac{\partial F_{\text{sys}}}{\partial x} \right|_T = - \frac{dF_{\text{sys}}}{d\lambda}. \quad (3)$$

An equivalent formulation of Eq. (2) is

$$X = 0. \quad (4)$$

The most familiar example of one component of this generalized force is pressure P and its associated displacement variable is volume V . For a reversible expansion of a gas, the total

generalized force will be the suitably formulated sum of the pressure force of the gas and the restraining forces on the piston that hold the system in equilibrium. They will sum to zero, as required by Eq. (4).

III.2 Limit States in Statistical Physics

If a system is in one of the limiting equilibrium states of Eq. (1) and Eq. (2) of ordinary thermodynamics, it is unchanging. If we allow for its molecular constitution, then the equilibrium is dynamic with its components interacting under the Hamiltonian evolution of a phase space. Through this internal dynamics, these states—now just called “limit states”—are no longer unchanging. They can migrate to neighboring states through what manifests macroscopically as thermal fluctuations. We will consider two cases.

First, consider an isolated system. It is microcanonical. That is, its probability density is uniform over its classical phase space. As it migrates over the phase space, the probability that the system is in some region of the phase space is proportional to its phase volume

$$\text{probability} \propto \text{phase volume.} \quad (5)$$

System states can be associated with regions of the phase space. The entropy S assigned to them is

$$S \propto k \ln (\text{phase volume}), \quad (6)$$

where k is Boltzmann’s constant. Combining we have

$$S \propto k \ln (\text{probability}) \quad \text{or} \quad \text{probability} \propto \exp(S/k) . \quad (7)$$

Einstein⁶ called Eq. (7) “Boltzmann’s principle” when he introduced it in his analysis of fluctuations. It tells us that isolated thermal systems can fluctuate from high to low entropy states, but only with very small probability.

Second, consider a system in a heat bath, with which it exchanges heat but no work, and is maintained by the bath at constant temperature T . The system will be canonically distributed over its phase space. That means that the probability density of finding the system at a phase point with energy E , in the course of its migration over the phase space, is proportional to $\exp(-E/kT)$. Hence, the probability that it is found in some subvolume V_{ph} of its whole phase space is proportional to the partition integral $Z(V_{\text{ph}})$, so that

$$\text{probability} \propto Z(V_{\text{ph}}) = \int_{V_{\text{ph}}} \exp(-E/kT) d\Omega, \quad (8)$$

where $d\Omega$ is the phase space volume element.⁷ If we associate states with volumes of the phase space, we have the canonical definition of free energy F is

$$F = -kT \ln Z. \quad (9)$$

Combining we have

$$F \propto -kT \ln (\text{probability}) \quad \text{or} \quad \text{probability} \propto \exp(-F/kT). \quad (10)$$

The limit states of a reversible process in an isolated system Eq. (1) have equal entropy S . It follows from Eq. (7) that thermal fluctuations can bring the system spontaneously to any of the limit states with equal probability:

$$P(\lambda_{\text{init}}) = \dots = P(\lambda) = \dots = P(\lambda_{\text{fin}}). \quad (11)$$

This result of equal probability obtains also for the limit states of a reversible process Eq. (2) in an isothermal system. For each state has equal free energy F and thus by Eq. (10) equal probability.

A familiar illustration of Eq. (11) is provided by a microscopically visible Brownian particle suspended in water in a dish. If λ is the position of the particle as it moves about, then each λ state has equal entropy S (if the dish is isolated); or equal free energy F (if the dish is in a heat bath). Over time, as it executes a random walk, the Brownian particle will visit each position and, according to Eq. (11), with equal probability. The time needed to realize these motions depends on the scale. For smaller Brownian particles, as their size approaches molecular scales, the motions become rapid, comparable to those of individual water molecules. For larger particles, approaching macroscopic sizes, the motions become so slow as to be negligible. A pea suspended in quiescent broth will eventually explore the complete bowl through its Brownian motion, but its migration will require eons and be undetectable on all normal time scales.

Allowing for the statistical character of the limiting equilibrium states of a thermodynamically reversible process thus reveals that they are no longer equilibrium states. Rather they are pseudo-equilibrium states in the sense that they are no longer unchanging and can migrate spontaneously through thermal fluctuations to other states. In macroscopic applications, this pseudo-equilibrium character can be ignored since the time scales needed for it to manifest are enormous. On molecular scales, this pseudo-equilibrium character can no longer be ignored.

III.3 Fluctuations Make Reversible Processes Impossible on Molecular Scales

To be a reversible process in ordinary thermodynamics, the states of the process must come arbitrarily close to limit states. As they do so, the states become ever more delicately balanced. In ordinary thermodynamics, these limit states are equilibrium states and there are no disturbing forces present to upset the delicate balance. This is no longer so once we allow for the statistical character of the limiting states. They are now pseudo-equilibrium states, confounded by fluctuations. If the system is in one of the limit states of Eq. (1) or Eq. (2) of some process, the effect of thermal fluctuations is to migrate the system through the other limit states of the process. These other limit states will be occupied with equal probability according to Eq. (11).

With macroscopic systems, the migration can be neglected since the time scales needed to realize it are enormous. The pea in quiescent broth mentioned above will eventually migrate over the entire bowl, but not in our lifetimes. With molecular scale systems, the migration will be rapid and completely disrupt the intended reversible process. We may initiate a molecular scale process in or very near to some state corresponding to λ_{init} and then expect that the system will very slowly migrate through the states of intermediate λ values, terminating in that of λ_{fin} . However thermal fluctuations will defeat these expectations and move the system rapidly among all the states. Termination will be impossible. If the system occupies a state at or near that of λ_{fin} , fluctuations will immediately divert it to other, earlier states in the process. Thermodynamically reversible processes on molecular scales are impossible.

III.4 Dissipation Suppresses Fluctuations Probabilistically

Once we allow that the limiting states are in pseudo-equilibrium, we see that an attempt at a reversible process can only be brought to completion if we introduce some dissipative, entropy creating disequilibrium that suppresses the fluctuations. The dissipation replaces the uniform probability distribution Eq. (11) by one that favors completion, which can only be assured to some nominated probability. That is, we set the ratio $P(\lambda_{\text{fin}})/P(\lambda_{\text{init}})$, which determines how much more likely the system is to settle into the final state λ_{fin} as opposed to reverting by fluctuations to the initial state λ_{init} . The corresponding dissipation is computed through equations Eq. (7) and Eq. (10). For an isolated system, the entropy change ΔS between initial and final states is

$$\Delta S = k \ln (P(\lambda_{\text{fin}})/P(\lambda_{\text{init}})) \quad \text{or} \quad P(\lambda_{\text{fin}})/P(\lambda_{\text{init}}) = \exp(\Delta S/k). \quad (12)$$

For a system in a heat bath at temperature T with which it exchanges no work, the free energy change ΔF between initial and final states is

$$\Delta F = -kT \ln (P(\lambda_{\text{fin}})/P(\lambda_{\text{init}})) \quad \text{or} \quad P(\lambda_{\text{fin}})/P(\lambda_{\text{init}}) = \exp(-\Delta F/kT). \quad (13)$$

These equations apply to a system that is initially set up in state λ_{init} , then released and the system allowed to equilibrate. $P(\lambda_{\text{fin}})$ is the probability that it will subsequently be found in state λ_{fin} . $P(\lambda_{\text{init}})$ is *not* the probability that the system was initially set up in state λ_{init} . It is the probability that the system, after achieving its new equilibration, reverts by a fluctuation to the initial state.

These two formulae Eqs. (12) and (13) do not give the total entropy and free energy changes directly for most processes. Commonly processes can only arrive at the final state if many other intermediate states are also accessible, such as the intermediate states of the expansion of a gas. Their accessibility leads to further dissipative creation of entropy or further free energy decreases. Since these intermediate states remain accessible, this further dissipation must be included in the computation of the total dissipation. To arrive at the minimum dissipation, all these other intermediate states, incompatible with the initial and final states, must be rendered highly improbable by careful design of the process. That is achievable but not done in most standard processes. If we do contrive the process so that the initial and final states only are accessible,⁸ then

$$P(\lambda_{\text{init}}) + P(\lambda_{\text{fin}}) = 1. \quad (14)$$

With this contrivance, the minimum entropy creation in an isolated system is⁹

$$\Delta S_{\text{min}} = k \ln \left(\frac{P(\lambda_{\text{init}}) + P(\lambda_{\text{fin}})}{P(\lambda_{\text{init}})} \right) = k \ln \left(1 + \frac{P(\lambda_{\text{fin}})}{P(\lambda_{\text{init}})} \right). \quad (15)$$

For a system in a heat bath at temperature T with which it exchanges no work, the minimum free energy change in executing the process is

$$\Delta F_{\text{min}} = -kT \ln \left(\frac{P(\lambda_{\text{init}}) + P(\lambda_{\text{fin}})}{P(\lambda_{\text{init}})} \right) = -kT \ln \left(1 + \frac{P(\lambda_{\text{fin}})}{P(\lambda_{\text{init}})} \right). \quad (16)$$

A modest probability ratio for success is:

$$P(\lambda_{\text{fin}})/P(\lambda_{\text{init}}) = 20 \quad \text{for which} \quad \Delta S = 3k \quad \text{and} \quad \Delta F = -3kT.$$

In molecular scale systems, a dissipation of entropy $3k$ and free energy $3kT$ is comparable to the entire amounts of entropy and free energy changing. It is a significant departure from equilibrium. Thus the conditions for completion of thermodynamically reversible process cannot be met at molecular scales: completion requires that the system *not* approach the limit states too closely, which entails that the process cannot be thermodynamically reversible.

For macroscopic systems with component numbers of the order of Avogadro's number $N = 6.022 \times 10^{23}$, quantities of entropy are of the order of Nk and quantities of free energy of NkT . The dissipation required is negligible. If completion is required with very high probability, we might choose the ratio:

$$P(\lambda_{\text{fin}})/P(\lambda_{\text{init}}) = 7.2 \times 10^{10}, \text{ for which } \Delta S = 25k \text{ and } \Delta F = -25kT.$$

This level of dissipation is still insignificant for macroscopic systems. Thus molecular-scale dissipation provides no obstacle to thermodynamically reversible processes at macroscopic scales.

If our intended process is the migration of a Brownian particle from one side of dish to the other, the entropy creating disequilibrium needed to suppress fluctuations is introduced by inclining the dish so that the Brownian particle is driven in the intended direction by gravity.

The quantities of entropy produced and the associated probabilities of completion are computed in the Appendix. It also illustrates a simple way in which the intermediate states can be made probabilistically inaccessible, in order to arrive at the case of minimum dissipation.

IV. SELF-CONTAINED, ISOTHERMAL EXPANSION OF A IDEAL GAS

The general results of Section III can be illustrated in the case of a self-contained, reversible, isothermal expansion of an ideal gas. For the results of Section III to apply, the analysis must include the mechanism through which the expanding gas is kept in near perfect equilibrium with the restraining piston. If that mechanism is the device of Section II that removes sand grains one at a time, its operation would have to be analyzed for dissipative processes. This analysis would be complicated. It would also be unnecessary, since there are simpler ways of achieving the same effect of a self-contained process. One way is to replace the homogeneous gravitational field acting on the piston by another, inhomogeneous field. It weakens as the piston rises by just the amount needed to maintain a mechanical balance of forces, without any manipulation of the weighting of the piston itself.¹⁰ Another approach is computed in detail

below. Through a simple mechanical contrivance described in Section IV.11, the piston area increases as the gas expands in such a way that the total upward force exerted by the gas on the piston remains constant, balancing the constant weight of the piston.

IV.1 The Confined Gas and the Stages of Its Expansion

An ideal gas of n monatomic molecules is contained in a chamber under a horizontal, weighted piston in a heat bath that maintains the system of gas and piston at a constant temperature T . The gas expands reversibly by raising the piston, passing work energy to the rising weight. The expansion is made self-contained by ensuring that the piston area $A(h)$ of the piston at height h increases by just the right amount that the weight of the piston always balances the mean pressure force of the gas for the limiting states. The expansion begins with the piston at $h = h_0$ when the gas has spatial volume $V(h_0)$ and ends at $h = h_1$ with gas spatial volume $V(h_1)$.

The stages of the process of expansion are, loosely speaking, parameterized by the height to which the gas has lifted the piston. This is not precisely correct since the fluctuating thermal energy of the piston will allow it to rise above the maximum extension of the gas. We shall see that this effect is negligible for a macroscopic gas, but is marked for a gas of one or few molecules. To accommodate this effect, the limiting equilibrium states associated with the expansion are parameterized by the height h above the chamber floor that demarcates the region accessible to the gas and the region accessible to the piston. That is, if the height of the i -th molecule is given by x_i and the height of the piston by x_{pist} , then the limiting equilibrium states are characterized by

$$0 < x_i < h, \text{ for all } i \quad \text{and} \quad x_{\text{pist}} \geq h . \quad (17)$$

The resulting “ h -states” are not completely disjoint in the sense that two may share some of the same microstates.

For example, states h and $2h$ may share the same microstate as follows. In state h , a thermal fluctuation may bring the piston to height $2h$, leaving all the gas molecules below height h . The same microstate may be associated with state $2h$ if all the gas molecules collect below height h through a thermal fluctuation.

This example makes clear that an extensive overlap of the microstates attached to h -states is improbable for a macroscopic gas of large n . For, as we shall see in calculations below, large volume fluctuations are extremely improbable in the short-term. Correspondingly, for large n ,

the mass of the piston will be great, so that the spatial extent of its short-term fluctuations will be small. However for a gas of one or few molecules, the fluctuations will be large in relation to the system size. As a result, a single microstate, specified by the position of the gas molecules and piston, can correspond to a wide range of h -states. This ambiguity in the h -states is part of the breakdown of reversible processes at molecular scales: there is a failure of distinctness of the individual stages through which we would like to the process to pass.

Figure 1 illustrates how h -states for heights h and $2h$ are almost certainly realized by distinct microstates, if the gas is macroscopic. However, just one microstate can realize both h -states for a gas of very few molecules.

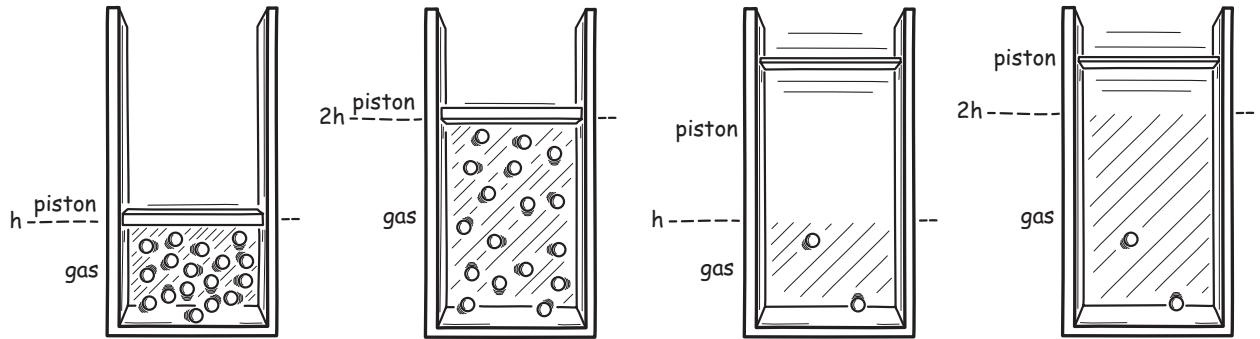

FIG. 1. Microstates of h -states are distinct only for macroscopic gases.

IV.2 Gas-Piston Hamiltonian

The n monatomic gas molecules, each of mass m , have canonical position and momentum coordinates $\mathbf{x} = (x_i, y_i, z_i)$, $\mathbf{p} = (p_{x_i}, p_{y_i}, p_{z_i})$, where $i = 1, \dots, n$. The piston of mass M has two relevant degrees of freedom, its vertical canonical position x_{pist} and its vertical canonical momentum p_{pist} . The combined Hamiltonian of the gas-piston system is

$$E_{\text{gas-piston}}(\mathbf{x}, \mathbf{p}; x_{\text{pist}}, p_{\text{pist}}) = E_{\text{gas}}(\mathbf{x}, \mathbf{p}) + E_{\text{piston}}(x_{\text{pist}}, p_{\text{pist}}), \quad \text{where } x_{\text{pist}} > x_i, \text{ all } i,$$

$$E_{\text{gas}}(\mathbf{x}, \mathbf{p}) = \sum_{i=1, n} p^2/2m \quad E_{\text{piston}}(x_{\text{pist}}, p_{\text{pist}}) = p_{\text{pist}}^2/2M + Mgx_{\text{pist}}. \quad (18)$$

The constant g is the acceleration due to gravity. It is assumed that the individual molecules do not feel the gravitational force acting on the piston.

The condition $x_{\text{pist}} > x_i$ asserts that the piston never falls to or below the height of the highest molecule. It expresses the coupling between gas and piston. The fact of this coupling

would mean normally that the gas-piston partition function does not factor. However the h -state of Eq. (17) has the fortunate property of breaking the coupling for each fixed value of h , so that the gas-piston partition integral for state h , $Z_{\text{gas-piston}}(h)$ is the product of the partition integrals for the individual gas and piston systems:

$$Z_{\text{gas-piston}}(h) = Z_{\text{gas}}(h) \cdot Z_{\text{piston}}(h), \quad (19)$$

and their free energies F , as given by the canonical formula $F = -kT \ln Z$, will sum

$$F_{\text{gas-piston}}(h) = F_{\text{gas}}(h) + F_{\text{piston}}(h). \quad (20)$$

This means that we can compute the thermodynamic properties of the gas and piston independently for these states.

IV.3. Gas Properties

The gas partition integral is

$$\begin{aligned} Z_{\text{gas}}(h) &= \int_{\text{all } \mathbf{x}, \mathbf{p}} \exp\left(-\frac{E(\mathbf{x}, \mathbf{p})}{kT}\right) d\mathbf{x} d\mathbf{p} \\ &= \prod_{i=1, n} \int_{\text{all } p_i} \exp\left(-\frac{p_{x_i}^2 + p_{y_i}^2 + p_{z_i}^2}{2mkT}\right) dp_{x_i} dp_{y_i} dp_{z_i} \prod_{i=1, n} \int_{x_i=0}^h \iint_{\text{accessible } y_i, z_i} dx_i dy_i dz_i \\ &= (2\pi mkT)^{3n/2} \prod_{i=1, n} \int_{x_i=0}^h A(x_i) dx_i = (2\pi mkT)^{3n/2} V(h)^n, \end{aligned} \quad (21)$$

where $A(x_i)$ is the gas chamber cross-sectional area at height x_i and $V(h)$ is the spatial volume accessible to the gas molecules between the chamber floor and height h . The canonical free energy is

$$F_{\text{gas}}(h) = -kT \ln Z_{\text{gas}}(h) = -nkT \ln V(h) + \text{const}_{\text{gas}}(T), \quad (22)$$

where $\text{const}_{\text{gas}}(T)$ is a constant independent of h . Since V is a monotonic function of h , we can use it as the path parameter λ to define the generalized force

$$X_{\text{gas}}(V) = -\left. \frac{\partial}{\partial V} \right|_T F_{\text{gas}}(V) = \frac{nkT}{V}. \quad (23)$$

That is, the generalized force is just the ordinary pressure of the gas according to the ideal gas law.

IV.4 Piston Properties

The piston partition integral is

$$\begin{aligned}
Z_{\text{piston}}(h) &= \int_{\text{all } p, x} \exp\left(-\frac{E_{\text{piston}}(x, p)}{kT}\right) dx dp \\
&= \int_{\text{all } p} \exp\left(-\frac{p^2}{2MkT}\right) dp \cdot \int_{x=h}^{\infty} \exp\left(-\frac{Mgx}{kT}\right) dx = \sqrt{2\pi MkT} \left(\frac{kT}{Mg}\right) \exp\left(-\frac{Mgh}{kT}\right). \quad (24)
\end{aligned}$$

The canonical free energy is

$$F_{\text{piston}}(h) = -kT \ln Z_{\text{piston}}(h) = Mgh + \text{const}_{\text{piston}}(T), \quad (25)$$

where $\text{const}_{\text{piston}}(T)$ is a constant independent of h . Using V as the path parameter, the generalized force is

$$X_{\text{piston}}(V) = -\left.\frac{\partial}{\partial V}\right|_T F_{\text{piston}}(V) = -\left.\frac{\partial}{\partial h}\right|_T F_{\text{piston}}(h) \cdot \frac{dh}{dV(h)} = -\frac{Mg}{A(h)}. \quad (26)$$

It is the ordinary gravitational force exerted per unit area by the weight of the piston.

IV.5. Balance of Forces

During the expansion, the piston rises from height $h = h_0$ to $h = h_1$. Associated with each height is a limit state in which the mean gas pressure force and piston weight are equal, in the correlate of the equilibrium of ordinary thermodynamics. We recover this equality from the condition for equilibrium: the free energy of the gas and piston system remains constant as in Eq. (2); or, equivalently, that the total generalized force vanishes as in Eq. (4). Setting the sum of the generalized forces of Eqs. (23) and (26) to zero, we have

$$\frac{nkT}{V(h)} - \frac{Mg}{A(h)} = 0. \quad (27)$$

Since $A(h) = dV(h)/dh$, this last condition gives the differential equation

$$A(h) = \frac{dV(h)}{dh} = \frac{Mg}{nkT} V(h), \quad (28)$$

for $h_0 < h < h_1$. The solution is

$$V(h) = V(h_0) \exp\left(\frac{Mg(h - h_0)}{nkT}\right) \quad (29)$$

and

$$A(h) = \frac{dV(h)}{dh} = \frac{Mg}{nkT} V(h_0) \exp\left(\frac{Mg(h - h_0)}{nkT}\right) = A(h_0) \exp\left(\frac{Mg(h - h_0)}{nkT}\right). \quad (30)$$

Equations (28) and (30) tell us that the gas volume and piston area must each grow exponentially with height h during the expansion $h_0 < h < h_1$ for equilibrium to be maintained.

The probability of $P(h)$ of each h -state is proportional to the partition integral

$Z_{\text{gas-piston}}(h) = Z_{\text{gas}}(h) \cdot Z_{\text{piston}}(h)$. It is given as

$$\begin{aligned} P(h) \propto Z_{\text{gas-piston}}(h) &= (2\pi mkT)^{3n/2} V(h)^n \sqrt{2\pi MkT} \left(\frac{kT}{Mg} \right) \exp\left(-\frac{Mgh}{kT} \right) \\ &= (2\pi mkT)^{3n/2} V(h_0)^n \sqrt{2\pi MkT} \left(\frac{kT}{Mg} \right) \exp\left(-\frac{Mgh_0}{kT} \right) = \text{constant}(T), \end{aligned} \quad (31)$$

where Eq. (29) was used to show

$$\begin{aligned} &V(h)^n \exp\left(-\frac{Mgh}{kT} \right) \\ &= V(h_0)^n \left[\exp\left(\frac{Mg(h-h_0)}{nkT} \right) \right]^n \exp\left(-\frac{Mg(h-h_0)}{kT} \right) \exp\left(-\frac{Mgh_0}{kT} \right) = V(h_0)^n \exp\left(-\frac{Mgh_0}{kT} \right). \end{aligned} \quad (32)$$

That is, Eq. (31) shows that each of the h -states is equally probable. It also follows from Eq. (31) that the free energy of each of these states is the same.

IV.6. Fluctuations Negligible for a Macroscopic Gas with Large n

In the h -state of Eq. (17), the mean gas pressure is balanced precisely by the weight of the piston. Fluctuations will lead the gas pressure force sometimes to exceed and sometimes to be less than the piston weight. As a result, the system will migrate up or down to neighboring, equally probable h -states. For a macroscopic gas, however, the migration will be so slow that it will not manifest on ordinary time scales.

To see this, recall that the motions that lead to the migration of the piston are due to the thermal fluctuations in the piston. The piston will have equipartition energy of $kT/2$ in its kinetic energy, $(1/2)Mv_{\text{rms}}^2$, where v_{rms} is the piston root-mean-square velocity. A liter of an ideal gas forms a cube of side 10cm and a piston area of 100 cm². At one atmosphere pressure, that is 1.0332 kg/cm² in engineering units, so the piston mass M is 103.32kg. Solving $(1/2)Mv_{\text{rms}}^2 = (1/2)kT$ at 25C, we find $v_{\text{rms}} = 0.06313 \text{ \AA/s}$. Since $1 \text{ \AA} = 10^{-10}\text{m}$ is ten orders of magnitude smaller than macroscopic scales and since this tiny speed will not be sustained unidirectionally

more than momentarily, the h -state is, on ordinary time scales and at macroscopic length scales, a quiescent state.

Another way to see that fluctuations are negligible for macroscopic systems is to look at the fluctuations in each of the gas and piston systems taken individually. If we assume that the piston is confined to heights $h \geq H$ but otherwise free, its positions will be Boltzmann distributed probabilistically according to a probability density over heights h

$$p_{piston}(h) = \frac{Mg}{kT} \exp\left(-\frac{Mg(h-H)}{kT}\right) \quad (33)$$

for $h \geq H$. This is an exponential distribution for which

$$\text{mean} = \text{standard deviation} = kT/Mg. \quad (34)$$

Thus kT/Mg is a measure of the linear size of the fluctuation-induced displacements of the piston from its floor height H .

This measure is very small in comparison with the overall linear size of the gas piston system. A convenient measure of the linear size of the gas is the ratio $V(H)/A(H)$. If the gas is confined to a cubical box, this ratio is the length of the side. We find directly from Eqs. (28) and (34) that

$$(\text{size of piston position fluctuations}) = (\text{linear size gas})/n. \quad (35)$$

For macroscopic samples of gases, n will be of the order of Avogadro's number $N = 6.022 \times 10^{23}$. Hence the fluctuation-induced disturbance to the equilibrium limit state will be negligible. For example, a liter of an ideal gas at 25C and one atmosphere pressure forms a cube of side 10 cm and contains 2.46×10^{22} molecules. According to Eq. (35), the linear size of the fluctuations is $10/(2.46 \times 10^{22})\text{cm} = 4.065 \times 10^{-14} \text{ \AA}$. That is, the size of the fluctuations is roughly 3 orders of magnitude smaller than atomic sizes.

Consideration of volume fluctuations in the gas yields similar negligible deviations. The probability that an ideal gas of n molecules of volume V fluctuates to a smaller volume $V-\Delta V$ is $[(V-\Delta V)/V]^n$. Since n is so large, this probability can only appreciably differ from zero if $\Delta V/V$ is very small, so that $[(V-\Delta V)/V]^n \approx [1 - n(\Delta V/V)] = [1 - \Delta V/(V/n)]$. This probability will still only appreciably differ from zero if the magnitude of the fluctuations ΔV is of the order of V/n or smaller. That is,

$$(\text{size of gas volume fluctuations}) < (\text{gas volume})/n. \quad (36)$$

The h -state of Eq. (17) does not represent perfectly the intermediate states of the gas expansion, since fluctuations in gas volume and piston position will breach the boundary at height h between the gas the piston. However, these calculations show that for macroscopic gases the breaches are entirely negligible.

Hence, a reversible gas expansion is quite achievable in the sense that its states can be brought arbitrarily close by macroscopic standards to the equilibrium states. Nonetheless, just as in the case of the Brownian motion of a macroscopic body, tiny fluctuations will accumulate over long times and eventually enable the gas-piston system to migrate over the full extent of configurations available to it. This migration is represented by the equal probabilities of all states of Eq. (11).

IV.7. Fluctuations for $n=1$

Matters change when we take small values of n . The extreme case of a one-molecule gas is dominated by fluctuations. The formulae developed above still apply. However we must now set $n = 1$ in them. In place of Eq. (35), we have a piston whose thermal fluctuations fling the piston through distances of the order of the size of the entire gas

$$(\text{size of piston position fluctuations}) = (\text{linear size gas}). \quad (37)$$

It is also evident without calculation that a gas of a single molecule is undergoing massive density fluctuations as the molecule moves from region to region. If we associate the volume of a gas with the places where its density is high, these in turn can be understood as volume fluctuations of the size of the gas confining chamber:

$$(\text{size of gas volume fluctuations}) \approx (\text{gas volume}). \quad (38)$$

That fluctuations will dominate is apparent from brief reflections without calculations. It is assumed that the pressure of the one molecule gas is sufficient to support the weight of the piston. That is, in molecular terms, repeated collisions with a single rapidly moving molecule are enough to support the mass of piston. This can only be the case if the piston mass itself is extremely light. If that is so, then its own thermal motion will be considerable.

These fluctuations defeat attempts to realize a thermodynamically reversible expansion of a gas of one or few molecules. In such an expansion, the gas state is always arbitrarily close to the limit states and it is supposed to migrate indefinitely slowly through them, under the delicate and very slight imbalance of pressure and weight forces. This circumstance is unrealizable. The

fluctuations just described will completely destabilize the delicate imbalance. If the gas-piston system has arrived at any height, fluctuations will immediately move it to a different height. A near completed expansion may be flung back to the start of the expansion, just as an unexpanded gas can be rapidly expanded by a fluctuation. Instead of rising serenely, the piston will jump about wildly with no discernible start or finish to the process.

IV.8 Suppressing Fluctuations: A Rough Estimate

An assured expansion, not confounded by fluctuations, will only be possible if we introduce enough disequilibrium to suppress the fluctuations. A very rough first estimate confirms that the dissipation will be considerable in relation to the quantities of entropy associated with the expansion of a one-molecule gas, but negligible for a macroscopic gas.

If the motion of expansion is to dominate the random thermal motions, then the vertical velocity of the piston in the overall process must greatly exceed the random thermal motions of the piston. Assume that the mass M of the piston is slightly smaller than the equilibrium value required in Eq. (28), so that there is a small, net upward force on the piston. This upward force gradually accelerates the piston until, at the end of its expansion, it has acquired the vertical speed v_{proc} and then slams to a halt. This process speed “proc” is a rough measure of the overall vertical motion of the piston.

The associated kinetic energy $(1/2)Mv_{\text{proc}}^2$ is derived from work done on the piston. It is potentially usable work energy that is lost as heat to the environment at the conclusion of the process. Had the process been carried out non-dissipatively, that is, reversibly, the only difference in the end state is that this lost work would have been stored as extra potential energy in the ascent of a weightier piston and the corresponding quantity of heat would not have been passed irreversibly to the environment.

The dissipation is represented most compactly in terms of free energy. The free energy change of the gas-piston system is

$$\Delta F = \Delta F_{\text{gas}} + \Delta F_{\text{pist}} = \Delta U_{\text{gas}} - T \Delta S_{\text{gas}} + \Delta U_{\text{pist}} - T \Delta S_{\text{pist}} \quad (39)$$

For a reversible, non-dissipative expansion, we have $\Delta F = 0$. Most of the terms in this expression remain the same if we now consider the dissipative expansion. The internal energy U_{gas} and entropy S_{gas} of the gas are functions of state, so they remain the same. The entropy of the piston

is unaltered; it is just a raised mass. So $\Delta S_{\text{pist}} = 0$. Overall, in the transition to a dissipative expansion, the free energy change ΔF is depressed from its zero value merely by the decrease in ΔU_{pist} below its reversible value in the amount of the lost work $(1/2)Mv_{\text{proc}}^2$. That is, we have

$$\Delta F = -(1/2)Mv_{\text{proc}}^2. \quad (40)$$

The dissipation can also be measured by an entropy change, but now we must consider the entropy of the gas, piston and environment together. If $\Delta U_{\text{env,rev}}$ is the change of internal energy of the environment in the case of the reversible process, then we have

$$\Delta U_{\text{env}} = \Delta U_{\text{env,rev}} + (1/2)Mv_{\text{proc}}^2. \quad (41)$$

Hence the total entropy change in the environment is

$$\Delta S_{\text{env}} = \Delta U_{\text{env,rev}}/T + (1/2)Mv_{\text{proc}}^2/T. \quad (42)$$

Since the start and end states of the gas are the same for the reversible and the irreversible processes and entropy is a function of state, the entropy change in the gas is the same for both processes. It follows that

$$\Delta S_{\text{gas}} = -\Delta U_{\text{env,rev}}/T, \quad (43)$$

so that the total entropy change for gas, piston and environment together is

$$\Delta S = \Delta S_{\text{gas}} + \Delta S_{\text{env}} = (1/2)Mv_{\text{proc}}^2/T. \quad (44)$$

Thus the net increase in entropy results entirely from the irreversible transfer of the potentially usable work as heat $Q = (1/2)Mv_{\text{proc}}^2$ to the environment, which creates entropy Q/T .

The random thermal motion of the piston is measured by its root-mean-square vertical speed, v_{therm} , that satisfies

$$(1/2)Mv_{\text{therm}}^2 = (1/2)kT. \quad (45)$$

The condition that random thermal motions not confound the process is

$$v_{\text{proc}} \gg v_{\text{therm}}. \quad (46)$$

It follows immediately from the two preceding equations that

$$\Delta F \ll -(1/2)kT \quad \text{and} \quad \Delta S \gg (1/2)k. \quad (47)$$

On molecular scales, this decrease in free energy or increase of entropy represents a considerable dissipation and departure from equilibrium. For comparison, the free energy and entropy changes usually attributed to a two-fold, reversible isothermal expansion of a one molecule gas are just $\Delta F = -kT \ln 2 = -0.69 kT$ and $\Delta S = k \ln 2 = 0.69 k$.

IV.9 Suppressing Fluctuations: Free Energy Changes

Lightening the piston mass so that $v_{\text{proc}} \gg v_{\text{therm}}$ enables the expansion to complete with dissipation Eq. (47) with a reasonably high, but unquantified, probability. A closer analysis using Eq. (13) provides quantitative relations among the amount of lightening of the mass, the dissipation and the probability of completion. We will find that negligible lightening and dissipation can assure completion with high probability for a macroscopic gas, but that no amount of lightening can achieve this for a one-molecule gas.

If M_{eq} is the equilibrium mass defined through Eq. (28), then we introduce a slight disequilibrium by setting the piston mass M to be slightly smaller

$$M = M_{\text{eq}} - \Delta M, \quad (48)$$

where $\Delta M > 0$. Instead of Eq. (31), we have for the probabilities $P(h)$ of the h -states

$$\begin{aligned} P(h) \propto Z_{\text{gas-piston}}(h) &= (2\pi mkT)^{3n/2} V(h)^n \sqrt{2\pi MkT} \left(\frac{kT}{Mg}\right) \exp\left(-\frac{Mgh}{kT}\right) \\ &= (2\pi mkT)^{3n/2} V(h_0)^n \sqrt{2\pi MkT} \left(\frac{kT}{Mg}\right) \exp\left(-\frac{Mgh_0}{kT}\right) \exp\left(\frac{\Delta Mg(h-h_0)}{kT}\right), \end{aligned} \quad (49)$$

since now

$$\begin{aligned} &V(h)^n \exp\left(-\frac{Mgh}{kT}\right) \\ &= V(h_0)^n \left[\exp\left(\frac{M_{\text{eq}}g(h-h_0)}{nkT}\right) \right]^n \exp\left(-\frac{(M_{\text{eq}} - \Delta M)g(h-h_0)}{kT}\right) \exp\left(-\frac{Mgh_0}{kT}\right) \\ &= V(h_0)^n \exp\left(-\frac{Mgh_0}{kT}\right) \exp\left(\frac{\Delta Mg(h-h_0)}{kT}\right). \end{aligned}$$

Most of the terms in Eq. (49) are independent of h , so it can be re-expressed more usefully as:¹¹

$$\frac{P(h_1)}{P(h_0)} = \exp\left(\frac{\Delta Mg(h_1 - h_0)}{kT}\right) = \frac{Z(h_1)}{Z(h_0)} = \exp\left(-\frac{\Delta F}{kT}\right). \quad (50)$$

The free energy change between the two states ΔF is introduced using the canonical formula $F = -kT \ln Z$. It follows that the free energy change is

$$\Delta F = -\Delta Mg(h_1 - h_0). \quad (51)$$

This relation admits the obvious reading: in reducing the piston mass by ΔM below the equilibrium mass M_{eq} , we lose the possibility of recovering work $\Delta Mg(h_1 - h_0)$ when the piston is

raised from height h_0 to h_1 . That work would otherwise appear as a corresponding increase in the potential energy of the unreduced piston of mass M .

We have already seen from Section III.4 that a macroscopically negligible free energy change $\Delta F = -25kT$ is sufficient to ensure a very favorable probability of completion. From Eq. (51), we see that this free energy change will correspond to a macroscopically negligible mass reduction. For a height difference of $(h_1 - h_0) = 10$ cm and a gas at 300K, the mass reduction is $\Delta M = 25kT/g(h_1 - h_0) = 1.05 \times 10^{-19}$ kg, which is considerably less than the 103.32 kg piston mass of Section IV.6.

In sum, a thermodynamically reversible expansion of a macroscopic gas is possible in this sense. The gas-piston system can expand slowly through a sequence of states that are, by macroscopic standards, very close to limit states that are stable in the shorter term. Fluctuations introduce negligible complications.

IV.10 Failure to Suppress Fluctuations for the One-Molecule Gas

The suppression of fluctuations breaks down completely, however, for a gas of one or few molecules. For the maximum suppression is achieved by reducing the mass of the piston arbitrarily close to zero mass. That is, we achieve the maximum probability ratio favoring completion in Eq. (50) when ΔM approaches its maximum value M_{eq} . This maximum is the case of a massless piston, which is no piston at all. It is simply releasing the gas freely into an infinite space. Then, a canonical probability distribution is not established and the probabilistic analysis used here does not apply. To preserve its applicability, consider instead the limiting behavior as ΔM approaches M_{eq} arbitrarily closely but never actually equals M_{eq} . Using Eq. (29) with Eq. (50), we have

$$\left(\frac{P(h_1)}{P(h_0)} \right)_{\Delta M \rightarrow M_{eq}} = \exp\left(\frac{M_{eq}g(h_1 - h_0)}{kT} \right) = \left[\exp\left(\frac{M_{eq}g(h_1 - h_0)}{nkT} \right) \right]^n = \left(\frac{V(h_1)}{V(h_0)} \right)^n. \quad (52)$$

The probability ratio Eq. (52) is just the probability ratio associated with a spontaneous recompression of the gas of n independently moving molecules from volume $V(h_1)$ to $V(h_0)$.

For gases of one or few molecules, the maximum of Eq. (52) presents serious problems. For the one-molecule gas undergoing a two-fold volume expansion, the largest probability ratio possible is just 2:1. Even in the most dissipative case, with the piston reduced to its lightest mass,

the expanding one-molecule gas is just twice as likely to be in the intended final state than in the initial state.

In sum, a thermodynamically reversible expansion of a gas of one or few molecules is impossible. Fluctuations prevent the states of the expansion migrating very close to and very slowly past the requisite sequence of pseudo-equilibrium states. In the system described, even dissipation in significant measure at molecular scales is unable to suppress the fluctuations. This in turn results from the limiting pseudo-equilibrium states themselves being so confounded by fluctuations that they cannot persist even briefly as stable states.

IV.11 How Piston Area Increases

It is not so straightforward to devise ordinary mechanical devices that can achieve the increase of piston area required by Eq. (30). The simplest arrangement, illustrated in Fig. 2, is to have a gas chamber of rectangular section that flares out horizontally in one direction with heights $h > h_0$. The chamber is fitted with a horizontal, rectangular piston that increases in area as it ascends, so it can keep the gas confined. The piston consists of two rectangular parts that slide frictionless over each other and are guided apart by rails as the piston ascends.

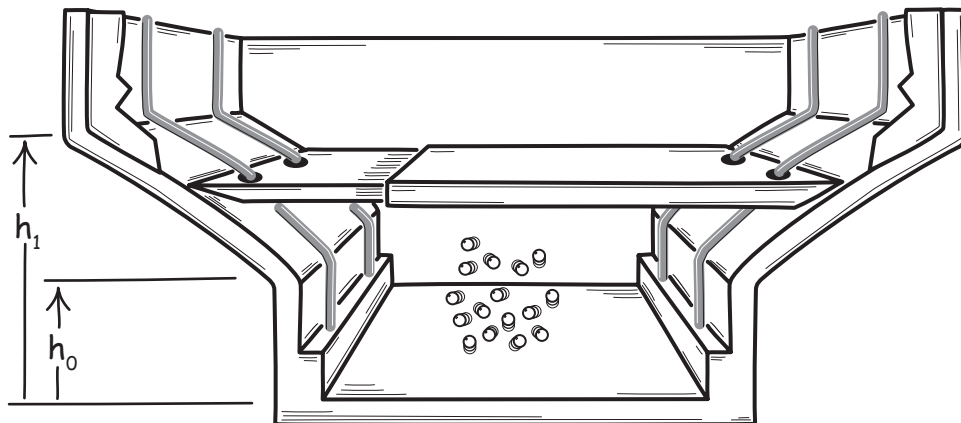

FIG. 2. A Weighted Piston that Maintains Equilibrium with an Expanding Gas

The sliding of the parts of the piston introduces new thermal degrees of freedom. They can be neglected since they are independent of the expansion. At all piston heights, each sliding part has the same slight horizontal motion corresponding to whatever slack is in the fitting of the rails to the parts. Since this slack will be the same at all stages of the expansion, they will

contribute an additive term to the piston Hamiltonian that is independent h and thus will not figure in the h dependence of the piston free energy of Eq. (25) or in the generalized force of Eq. (26).

Finally, the expansion under this scheme cannot continue indefinitely. Otherwise the gas-piston system can access an infinity of equally accessible stages of expansion, which means that it will never achieve equilibrium. The probability distributions used above, however, depend on the assumption that equilibrium has been achieved. The expansion could be halted by placing a maximum stop on the piston at some maximum height. This, however, would introduce complicating thermal effects. As the piston approaches the stop, it would behave like a one-molecule gas and resist compression. The simplest remedy is to assume that, at some height $H_{\max} \geq h_1$, the chamber-piston system reverts to one with constant piston area. Then achieving greater stages of expansion ceases to be equally easy and an equilibration is possible.

V. CONCLUSION

The accommodation of the molecular constitution of matter by ordinary thermodynamics introduces negligible complications for the thermodynamic analysis of macroscopic systems. However, as a matter of principle, once we take into account all the processes involved, thermal fluctuations preclude thermodynamically reversible processes in systems at molecular scales. This has been shown in Section 3 for the general case of any isolated system and for any system maintained at constant temperature by a heat bath with which it exchanges no work.

In standard treatments of molecular scale systems, thermodynamically reversible processes are described as advancing very slowly under the guidance of a parameter that is manipulated externally by unspecified processes. The requisite precise, external control of the parameter is only possible through considerable dissipation in those unspecified processes. It renders the overall process irreversible. The neglect of this additional dissipation masks the impossibility described here.

The most general result is the impossibility of a reversible process for any isolated, molecular scale system since it covers all other cases. Imagine that somehow we could realize a reversible process in some part of an isolated system. Since reversibility is unachievable for the total isolated system, there must be an unaccounted dissipation in some other part of the system.

The impossibility of molecular scale, thermodynamically reversible processes derives from Eqs. (11), (12) and (13) of Sections III.2 and III.4, which apply quite generally. If we have a process that is intended to be thermodynamically reversible, Eq. (11) tells us that thermal fluctuations lead the system to meander back and forth indefinitely if its states are in or arbitrarily near the limiting states. They will eventually realize a uniform probability distribution over the process stages. Such a process does not complete. Eq. (12) and (13) determine the order of magnitude of the dissipation needed to overcome the fluctuations and assure probabilistic completion of the intended process. Eqs. (15) and (16) give the minimum dissipation in a special circumstance contrived to be least dissipative. The dissipation is negligible on macroscopic scales and significant on molecular scales.

The idea that one could undertake a thermodynamically reversible expansion of a gas of a single molecule was introduced by Szilard¹² as part of his celebrated analysis of Maxwell's demon. The idea has become standard in the now voluminous literature that develops Szilard's work.¹³ Szilard¹⁴ briefly recognized the problem that the gas pressure is wildly fluctuating, as it acts to lift a weight coupled to the piston. The problem is dismissed with the parenthetically inserted remark:

The transmission of force to the weight is best arranged so that the force exerted by the weight on the piston at any position of the latter equals the average pressure of the gas.

We have now seen here in detail that this is an inadequate response. There is no arrangement that can convey the work done by the expanding one-molecule gas to a raised weight in a way that maintains thermodynamic reversibility of the entire process. Any arrangement, no matter how simple or complicated in design, is subject to the above general relations. They affirm that fluctuations will disrupt the intended operation, unless the fluctuations can be suppressed by the dissipative creation of entropy in quantities significant at molecular scales.

APPENDIX. MOVING A BROWNIAN PARTICLE

A microscopically visible Brownian particle is suspended in a flat, horizontal dish of water that is maintained at constant temperature T by a heat bath. A candidate thermodynamically reversible process is the slow moving of the particle from one side of the

dish to the other. Its analysis is one of the simplest illustrations of the general results of Section III.

A1. A Small Particle in Ordinary Thermodynamics.

If we neglect the molecular constitution of matter and orient the dish horizontally, then the system of particle and water is in perfect equilibrium and will never change. We can move the particle slowly from one side of the dish to the other by tilting the dish slightly, so that the particle falls slowly under gravity. The particle has effective mass M , which is its apparent weight after buoyancy is subtracted. When it falls through a height H , it loses potential energy MgH , where g is the acceleration due to gravity. This energy is lost as work that is converted irreversibly via friction to heat and is passed to the heat bath. Hence the free energy change, due solely to the change of internal energy of the particle, is

$$\Delta F = -MgH. \quad (53)$$

To realize the process reversibly, this height H can be made arbitrarily small so that ΔF is brought arbitrarily close to zero. With successively smaller H , the particle will still move across the dish, but now take successively longer times. The limiting equilibrium states are the different immobile equilibrium positions the particle can take in the fully horizontal dish.

A2. Brownian Motion

Now allow for the molecular constitution of water. As a result of continuing collisions with very many water molecules, the particle adopts the fluctuating motion known as Brownian motion. Over time, the Brownian particle will migrate throughout the accessible regions of water. As Einstein¹⁵ showed in 1905, the particle can now be treated as a one-molecule ideal gas.

This migration over positions by Brownian motion is an example of how fluctuations affect what was considered in ordinary thermodynamic to be an equilibrium system. They are led to migrate to neighboring states and beyond. The distances migrated in some nominated time lie on a bell curve whose spread is measured by its standard deviation. For a 0.001mm diameter spherical particle in water at 17C, Einstein¹⁶ estimated a standard deviation of 8×10^{-7} m over one second.¹⁷ This standard deviation scales with $\sqrt{(\text{time})/(\text{particle diameter})}$. A macroscopic body of 1cm radius is 10,000 times larger. Hence the standard deviation for its motion in one

second is 100 times smaller: $8 \times 10^{-9} \text{m} = 80 \text{\AA}$. Since the standard deviation scales with $\sqrt{\text{time}}$, this standard deviation grows to a macroscopic $8 \times 10^{-3} \text{m} = 8 \text{mm}$ only after $(10^6)^2 = 10^{12}$ seconds = 31,688 years. The extent of these motions is, for macroscopic bodies, so small as to be negligible.

For microscopic bodies and smaller, these motions are significant. A particle localized in one small part of the water dish ceases to be in an equilibrium state. The particle will proceed to explore the entire volume of the dish through its random thermal motions. In this aspect, it is akin to a one-molecule ideal gas expanding irreversibly into a large chamber. If the particle is initially localized in a small volume ΔV of the dish of total volume V , then the associated entropy and free energy changes are given by

$$\Delta S = k \ln (V/\Delta V) \quad \Delta F = -kT \ln (V/\Delta V) \quad (54)$$

The probability distribution of the resulting fully expanded equilibrium state is canonical. The probability that the particle will be found at any given position \mathbf{x} in the water is proportional to $\exp(-E(\mathbf{x})/kT)$, where $E(\mathbf{x})$ is the energy of the particle at spatial position \mathbf{x} . Since this energy is constant over all positions in a thin horizontal dish, it follows that the probability of occupation by the particle is distributed uniformly over all position. This uniform distribution is a simple example of the equiprobable relations of Eq. (11).

A3. The Gravity Driven Particle

A thermodynamic process that seeks to move the particle from one side of the dish to the other can only succeed if it overcomes or suppresses these fluctuations. That suppression is effected by inclining the dish and introducing a sufficiently large gravitational driving force, as in the case of ordinary thermodynamics. Fig. 3 shows the inclined dish. The particle is released in its initial state “init” in the highest part, with height $h = H - \Delta H$ to H . We seek to move it to the final state “fin,” $h = 0$ to ΔH .

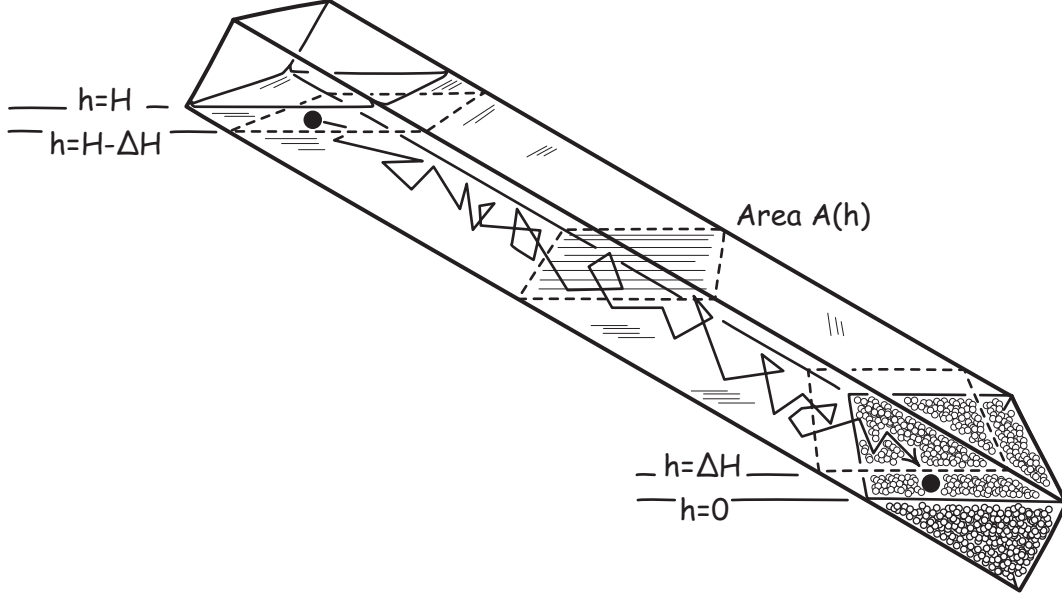

FIG. 3. Gravity Suppresses Fluctuations in a Brownian Particle

The particle Hamiltonian is

$$E = p^2/2m + Mgh, \quad (55)$$

where its momentum is $\mathbf{p} = (p_x, p_y, p_z)$, its position is $\mathbf{x} = (x, y, z) = (h, y, z)$ and m is the full mass of the particle, uncorrected for buoyancy. The horizontal cross-sectional area of the dish at height h is $A(h)$. The general partition integral for phase space volume delimited by $h=h_1$ and $h=h_2$ is:

$$\begin{aligned} Z(h_1, h_2) &= \int_{h=h_1}^{h_2} \int_{\text{all } p, y, z} \exp\left(-\frac{E(\mathbf{x}, \mathbf{p})}{kT}\right) dp dy dz dh \\ &= \int_{\text{all } p} \exp\left(-\frac{p^2}{2mkT}\right) dp \cdot \int_{h=h_1}^{h_2} \exp\left(-\frac{Mgh}{kT}\right) \iint_{\text{in } A(h)}^{y, z} A(h) dy dz dh. \end{aligned} \quad (56)$$

For the special case of $A(h) = A$, we have

$$Z(h_1, h_2) = (2\pi kTm)^{3/2} \cdot A \cdot \left(\frac{kT}{Mg}\right) \left[\exp\left(-\frac{Mgh_1}{kT}\right) - \exp\left(-\frac{Mgh_2}{kT}\right) \right]. \quad (57)$$

Particular values for the total, initial, final and middle states are

$$\begin{aligned} Z_{\text{total}} &= Z(0, H) = (2\pi kTm)^{3/2} \cdot A \cdot \left(\frac{kT}{Mg}\right) \left[1 - \exp\left(-\frac{MgH}{kT}\right) \right], \\ Z_{\text{init}} &= Z(H - \Delta H, H) = (2\pi kTm)^{3/2} \cdot A \cdot \left(\frac{kT}{Mg}\right) \exp\left(-\frac{MgH}{kT}\right) \left[\exp\left(\frac{Mg\Delta H}{kT}\right) - 1 \right] \end{aligned}$$

$$\approx (2\pi kTm)^{3/2} \cdot A \cdot \exp\left(-\frac{MgH}{kT}\right) \Delta H,$$

$$Z_{fin} = Z(0, \Delta H) = (2\pi kTm)^{3/2} \cdot A \cdot \left(\frac{kT}{Mg}\right) \left[1 - \exp\left(-\frac{Mg\Delta H}{kT}\right)\right] = (2\pi kTm)^{3/2} \cdot A \cdot \Delta H,$$

$$Z_{mid} = Z_{total} - Z_{init} - Z_{fin}.$$

where ΔH is assumed small so that $\exp\left(-\frac{Mg\Delta H}{kT}\right) \approx 1 - \left(\frac{Mg\Delta H}{kT}\right)$.

In the process, the system expands from the “init” state to the “total” state, much of which latter state comprises “fin.” The free energy change is

$$\Delta F = -kT \ln\left(\frac{Z_{total}}{Z_{init}}\right) = -kT \ln\left(\frac{Z_{init} + Z_{fin}}{Z_{init}} \cdot \frac{Z_{total}}{Z_{init} + Z_{fin}}\right) = -kT \ln\left(1 + \frac{Z_{fin}}{Z_{init}}\right) + kT \ln\left(1 - \frac{Z_{mid}}{Z_{total}}\right).$$

Since $Z_{fin}/Z_{init} = P_{fin}/P_{init}$, $Z_{mid}/Z_{total} = P_{mid}/P_{total}$ and using Eq. (16) to introduce ΔF_{min} , this can be rewritten as

$$\Delta F = -kT \ln\left(\frac{Z_{total}}{Z_{init}}\right) = \Delta F_{min} + kT \ln\left(1 - \frac{P_{mid}}{P_{total}}\right), \quad (58)$$

where ΔF_{min} is the minimum free energy decrease needed to assure completion with probability P_{fin} . To assure a high probability of completion, we seek P_{fin} much greater than the probability P_{init} that the process reverts by a fluctuation back the initial state. That is we seek

$$\frac{P_{fin}}{P_{init}} = \frac{Z_{fin}}{Z_{init}} = \exp\left(\frac{MgH}{kT}\right) \gg 1. \quad (59)$$

Under this assumption,

$$\begin{aligned} \Delta F_{min} &= -kT \ln\left(\exp\left(\frac{MgH}{kT}\right) + 1\right) = -kT \ln\left(\exp\left(\frac{MgH}{kT}\right) \left(1 + \exp\left(-\frac{MgH}{kT}\right)\right)\right) \\ &= -kT \ln \exp\left(\frac{MgH}{kT}\right) - kT \ln\left(1 + \exp\left(-\frac{MgH}{kT}\right)\right) \\ &\approx -MgH - kT \exp\left(-\frac{MgH}{kT}\right) = -MgH - kT \frac{P_{init}}{P_{fin}}. \end{aligned} \quad (60)$$

To assess the second term in (58), we note that

$$1 - \frac{P_{mid}}{P_{total}} = \frac{Z_{init} + Z_{fin}}{Z_{total}} \approx \frac{\exp\left(-\frac{MgH}{kT}\right)\Delta H + \Delta H}{\left(\frac{kT}{Mg}\right)\left[1 - \exp\left(-\frac{MgH}{kT}\right)\right]} \approx \frac{Mg\Delta H}{kT} = \frac{MgH}{kT} \cdot \frac{\Delta H}{H}.$$

That is, we have from Eq. (58) that

$$\Delta F - \Delta F_{min} = kT \ln\left(\frac{MgH}{kT}\right) - kT \ln\left(\frac{H}{\Delta H}\right). \quad (61)$$

A4. Minimum Dissipation Needed to Suppress Fluctuations

The dissipation needed to suppress fluctuations, measured as a free energy decrease, is given by Eq. (58). The quantity ΔF_{min} is the minimum dissipation required by Eq. (16) above to enforce completion of the process with probability ratio P_{fin}/P_{init} . Inverting Eq. (59), we have that securing this probability ratio requires a minimum H of

$$H = \frac{kT}{Mg} \ln\left(\frac{P_{fin}}{P_{init}}\right).$$

This minimum dissipation ΔF_{min} is computed in Eq. (60), where (in addition to a small correction term) it is found to be approximately equal to $-MgH$. This is just the free energy decrease of Eq. (53) associated with the particle falling through a height H .

The second term in Eq. (58), $kT \ln\left(1 - \frac{P_{mid}}{P_{total}}\right)$, represents additional dissipation that results from the accessibility of intermediate or middle “mid” states in $h=\Delta H$ to $h=H-\Delta H$. This additional dissipation is approximated in Eq. (61). The major part of the additional dissipation comes from the term $-kT \ln\left(\frac{H}{\Delta H}\right)$. It corresponds to the entropy creation in Eq. (54) due to the $H/\Delta H = V/\Delta V$ fold expansion of the particle from its confinement in the small volume ΔV to the large volume V .

To secure the minimum dissipation, we need to devise a way to make these intermediate “mid” states probabilistically inaccessible, so that its probability $P_{mid} \approx 0$. If that can be done, then additional dissipation beyond the minimum can be reduced to zero. For, from Eq. (58),

$$\Delta F - \Delta F_{\min} = kT \ln\left(1 - \frac{P_{\text{mid}}}{P_{\text{total}}}\right) \approx kT \ln(1) = 0$$

In this case, rendering the intermediate states probabilistically inaccessible is easy to achieve. We merely replace the intermediate sections of the dish by an extremely narrow channel of small, constant cross-sectional area A_{mid} , as shown in Fig. 4.

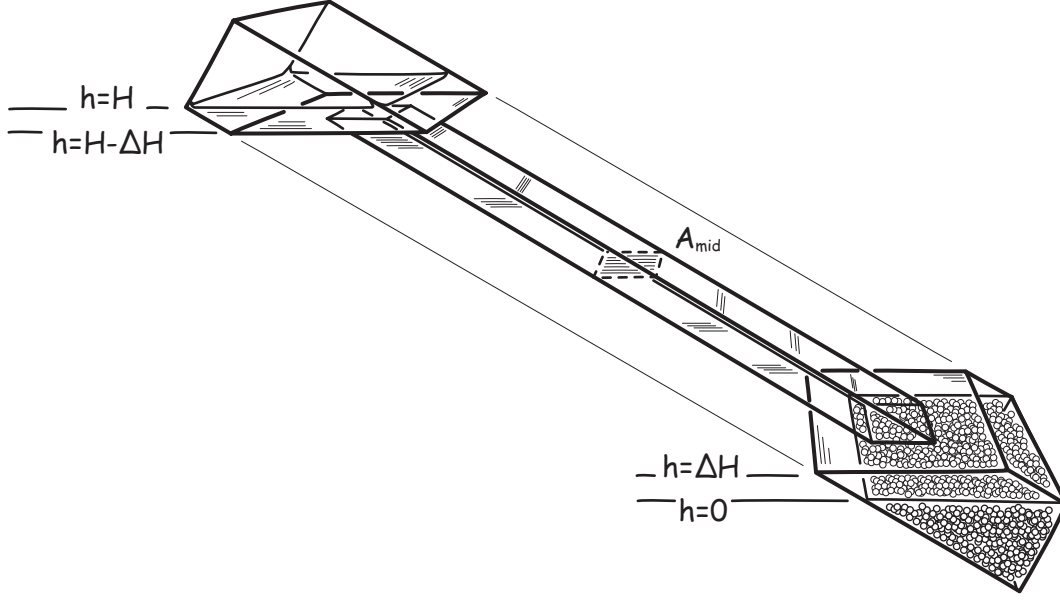

FIG. 4. Dish with Spatial Volume of Intermediate States Reduced.

It follows from Eq. (56) that the partition integral $Z_{\text{mid}} = Z(\Delta H, H-\Delta H)$ is proportional to A_{mid} . Thus, by making A_{mid} arbitrarily small, we can render Z_{mid} and, as a result, P_{mid} arbitrarily small as well.

¹ Such as in Hendrick C. Van Ness, *Understanding Thermodynamics*. (New York: McGraw-Hill, 1969; reprinted, New York: Dover, 1983), pp. 19-22.

² Christopher Jarzynski, "Nonequilibrium Equality for Free Energy Differences," *Physical Review Letters*, **78**(No. 14), 2690-2693 (1997) on p. 2690.

³ R. Kawai, J. M. R. Parrondo, and C. Van den Broeck, "Dissipation: The Phase-Space Perspective," *Physical Review Letters*, **98**, 080602 (2007) on p. 080602-1.

⁴ To see this, for small changes, we have

$$dF_{\text{sys}} = d(U_{\text{sys}} - TS_{\text{sys}}) = dU_{\text{sys}} - TdS_{\text{sys}} = dU_{\text{sys}} + dU_{\text{env}} = dU_{\text{tot}} = 0$$

where the heat passed to the environment in the reversible process is $dQ_{\text{sys}} = TdS_{\text{sys}}$, which equals the energy change in the environment dU_{env} .

⁵ For a small, reversible change, we have $dF_{\text{sys}} = dU_{\text{sys}} - TdU_{\text{sys}} = dU_{\text{sys}} - dQ = -dW$, so that $-dF_{\text{sys}}/dx = dW/dx = X$.

⁶ Albert Einstein, "On a Heuristic Viewpoint Concerning the Production and Transformation of Light." *Annalen der Physik*, **17**, 132-148 (1905) in §5.

⁷ To connect with the usual statement of the canonical distribution, if $V_{\text{ph,tot}}$ is the volume of the full phase space accessible to the system, then the canonical distribution is

$p = \exp(-E/kT) / Z(V_{\text{ph,tot}})$ and the probability that the system is in subvolume V_{ph} is equal to $Z(V_{\text{ph}}) / Z(V_{\text{ph,tot}})$.

⁸ The intermediate states can never be completely inaccessible or the process could not proceed. Rather the process design must be such as to make them accessible only with arbitrarily small probability.

⁹ Eqs. (15) and (16) with a term $\ln(1 + P(\lambda_{\text{fin}})/P(\lambda_{\text{init}}))$ give slightly higher dissipation than the corresponding formulae (22) and (23) of an earlier paper (John D. Norton, "All Shook Up: Fluctuations, Maxwell's Demon and the Thermodynamics of Computation," *Entropy*, **15**, pp. 4432-83 (2013).), which instead have a term $\ln(P(\lambda_{\text{fin}})/P(\lambda_{\text{init}}))$. The latter formulae presumed that the process ends in a way that prevents return to the initial state. In the absence of a non-dissipative way of preventing this return, the newer formulae provide a better limit.

¹⁰ See §7.5 of John D. Norton, "Waiting for Landauer," *Studies in History and Philosophy of Modern Physics*, **42**, 184-98 (2011).

¹¹ These two probabilities are to be read as follows: over the longer term in which the gas-piston system fully explores the phase space accessible to it, it comes to an equilibrium with probability $P(h_0)$ of the initial compressed h-state and probability $P(h_1)$ of the final, expanded h-state.

¹² Leo Szilard, "On the Decrease of Entropy in a Thermodynamic System by the Intervention of Intelligent Beings," (1929) in *The Collected Works of Leo Szilard: Scientific Papers*. (MIT Press: Cambridge, MA, 1972), pp. 120–129.

¹³ For a survey and collection of works, see Harvey S. Leff and Andrew Rex, eds. *Maxwell's Demon 2: Entropy, Classical and Quantum Information, Computing*. (Bristol and Philadelphia: Institute of Physics Publishing, 2003).

¹⁴ Ref. 13, p. 122.

¹⁵ Albert Einstein, *Investigations on the Theory of the Brownian Movement*. Trans. A. D. Cowper. (Methuen & Co., 1926; reprinted, New York: Dover, 1956).

¹⁶ Ref. 15, p. 18.

¹⁷ The editors of the *Einstein Papers* note that Einstein's calculation actually pertains to water at 9.5°C. See John Stachel, et al. (eds.), *The Collected Papers of Albert Einstein: Volume 2: The Swiss Years: Writing, 1900–1902*. (Princeton: Princeton University Press, 1989) on. p. 236.