

QUANTIFIER SCOPE: HOW LABOR IS DIVIDED BETWEEN QR AND CHOICE FUNCTIONS¹

It is well known that quantifiers in natural language can take scope wider than where they occur overtly. This has been captured by assuming either a covert syntactic operation (QR), which generates the relevant scope, or by various equivalents in terms of quantifier-storage. However, since the introduction of such procedures, in the seventies, it was discovered that the actual options of covert scope appear inconsistent with what would be entailed by one well-behaved syntactic operation, like QR. On the one hand, many quantifiers are much more restricted than predicted by QR. On the other, certain existential NPs allow free wide scope, that violates all constraints on movement. As a result, the optimistic view of the seventies has been gradually replaced by highly stipulative lists of constraints.

I will argue that the early optimism need not, in fact, be abandoned. To the extent that QR can apply to generate covert scope, it behaves as entailed by standard constraints on movement. The real problem is posed only by a subset of the indefinite NPs, which do not behave as standard generalized quantifiers (over singular individuals). Lacking a (GQ) determiner, they are interpreted, locally, by choice-functions, and the function-variable can be existentially closed arbitrary far away, thus allowing them free scope. This is the same procedure needed, independently, to derive the collective interpretation of plural indefinites of this type.

1. QUANTIFIER SCOPE: THE STATE OF THE ARTS

1.1. *The Optimistic QR View of the Seventies*

One of the strongest arguments for the introduction of QR in the syntactic framework, was a correlation which was observed in the seventies (Rodman (1975)) between the options of covert wide quantifier scope and those

¹ I would like to thank Danny Fox, Genarro Chierchia, Irene Heim, Anna Szabolcsi and, especially, Remko Scha and Yoad Winter, for many helpful comments at various stages of this paper. Yoad Winter's contribution to the analysis of choice functions, in Section 6, goes far beyond his articles on the matter (Winter, 1995, 1997). Many of the ideas here were intensively discussed with him before they took their present form.

of overt *wh*-movement.² Although not much seems left, currently, of the optimism that surrounded this generalization, let me nevertheless illustrate it with a case where it happens to be true, as a first step in my attempt to restore that early optimism. In the sentences of (1), the quantified NP *every new patient* can take scope over the whole matrix clause, i.e. the choice of doctor can vary with the choice of a patient. This correlates with the fact that an extraction of a *wh* constituent is possible from precisely the same positions in (2). In (4), by contrast, island constraints on movement prevent *wh*-movement. Correspondingly, the sentences in (3), do not allow *every new patient* to be interpreted with wide scope (over *a doctor*)

- (1)a. A doctor will interview every new patient.
 b. A doctor will try to assist every new patient personally.
 c. A doctor will make sure that we give every new patient a tranquilizer.
- (2)a. Which patients will a doctor interview *e*?
 b. Which patients will a doctor try to assist *e* personally?
 c. Which patients will a doctor make sure that we give *e* a tranquilizer?
- (3)a. A doctor will examine the possibility that we give every new patient a tranquilizer.
 b. A doctor should worry if we sedate every new patient.
- (4)a. *Which patients will a doctor examine the possibility that we give *e* a tranquilizer?
 b. *Which patients should a doctor worry if we sedate *e*?

In examples like these, the correlation appears complete up to the finer grains. Thus, while *wh*-movement is possible out of an embedded tensed clause, as in (2c), it is more difficult (and thus, more context-dependent) than extraction out of an infinitival clause, as in (2b). Correspondingly, it was widely observed that it is easier for a quantified NP to take wide scope outside its clause when the clause is not tensed.

If true, this correlation speaks strongly in favor of capturing scope by covert syntactic movement: The scope of a quantifier is always determined by its syntactic position, but this position need not always be that in which

² Rodman stated his findings as a descriptive generalization (mainly about scope out of relative clauses). Chomsky (1975) argued that “the quantificational property that Rodman noted is a special case of a much more general principle . . . namely that all transformational rules are restricted to adjacent cyclic nodes” (p. 105). (That principle is known as ‘subjacency’.)

it is realized phonetically.³ Of course, there is also danger in allowing covert syntactic operations. If arbitrary syntactic operations could take place invisibly, it would be a mystery how speakers using language can know what the others are saying. This was among the reasons why the enthusiasm with QR was not shared by all in the seventies.⁴ But if the correlation observed is true, this danger is under control. The set of operations allowed invisibly is precisely the same set which applies also overtly, so the possible covert derivations from a given phonetic realization of a sentence can be easily computed.⁵ Furthermore, if such correlation exists, it is hard to explain it in any non stipulative way in frameworks capturing all scope construals in situ, such as quantifier-storage.⁶

However, the scope picture has turned out to be much less neat than the facts in (1)–(4) suggest. Already in the seventies it was observed that quantifiers are not all alike in their options for covert scope. In the case of strong (universal) quantifiers, Ioup (1975) argued that its availability varies so dramatically with the choice of determiner and with the context, that it is not clear that one neat generalization can be maintained. (A similar pessimistic conclusion has been reached, lately, in Szabolcsi (1995).) Thus, while *each* appears to behave pretty much as predicted by QR, *every* is much more restricted. Many (e.g. Farkas 1981) have argued that most strong quantifiers are actually restricted to have scope only in

³ Historically, it was believed, in the syntactic framework, that QR is needed also independently of the question of non-overt scope, and it applies to all quantifiers regardless of their scope, in order to allow classical logic interpretation for them. This belief, which is purely theory internal, was never, in fact, founded. (For example, no answer was given as to how quantifiers like *most* are interpreted within classical logic.) I assume throughout that quantifiers are interpretable in-situ, as in the Montague tradition, and the only question is non-overt scope, for which a structure distinct from the overt structure was assumed also by Montague.

⁴ For example, my view in Reinhart (1976) (which I no longer hold) was that there is no sufficient evidence for the introduction of such dangerous covert operations. I argued that in the case of universal quantifiers, non overt scope construals are extremely hard to get, and in the case of existentials, the apparent wide scope is reducible to vagueness. At most, we need some mechanism deriving marked interpretations, as proposed also in Keenan and Faltz (1978).

⁵ In the current – minimalist – stage of syntactic theory (Chomsky, 1994), there is nothing peculiar to quantification in assuming covert movement (chain formation). The view is that a derivation of a sentence can be spelled out phonetically at any stage (subject to the relevant spell-out conditions). Languages may vary regarding where spell-out takes place, which is the source of word order variation. There is, therefore, nothing particularly puzzling about operations continuing at the covert structure, which may, then, effect the interpretation (though there is a serious question regarding what drives and restricts such operations).

⁶ It is possible to develop semantics that capture all scope construals compositionally in situ, as shown in Hendriks (1993). But why it should be restricted by syntactic islands remains a mystery.

their clause. Still, patterns as exemplified in (1) exist, and no systematic account is available as to why in some contexts it is easy to get such a pattern and in others, virtually impossible.

This is not necessarily evidence against the original QR view, since it is possible that further contextual considerations that we do not understand yet affect the ease of applying QR. The devastating problem is that existentially quantified NPs go in precisely the opposite direction, showing massive and systematic violations of syntactic restrictions on movement.

1.2. *The Syntactic Freedom of Existential Wide Scope*

It has been largely acknowledged that many indefinite NPs appear to show scope-freedom that defies anything we know about disciplined syntactic behavior. These are all weak, or 'existential', in the sense of Keenan (1987). They include indefinite singular NPs, cardinal plurals (including *many*), and *wh*-NPs. I will refer to them for the time being as existential, or indefinite NPs, and I will return to the question what exactly the relevant set consists of, in Section 6.4.

Typically, existential NPs are indifferent to islands. The facts themselves have been known for a while, and even encoded in the syntax of QR, as we shall see. But recently, it has been noted, independently, in three different areas, that there are serious additional problems lurking behind these facts. In the area of quantifier scope, Ruys (1992) and Abusch (1994) show that the existing analyses do not always capture correctly the scope of existentials. In the case of questions, Reinhart (1992) argues that *wh*-in-situ are plainly uninterpretable in any of the available LF analyses. Chung, Ladusaw and McCloskey (1994) show that under all current LF views, sluicing is an enormous mystery. Let me first illustrate the syntactic freedom of existentials in these three areas, and the problems it presents will unfold gradually.

We may use (5) as a comparison basis for the difference in the scope options of strong quantifiers and the relevant existential ones. The (italicized) strong QNPs in these examples cannot have the higher existential in their scope. In terms of QR, this means that they cannot be extracted out of the syntactic island.

- (5) a. Someone reported that Max and *all the ladies* disappeared.
- b. Someone will be offended if we don't invite *most philosophers*.
- c. Many students believe anything that *every teacher* says.

But if an existential occurs in the same position, as in (6), it appears to have no problem taking scope over the whole sentence (The choice of

ladies, philosophers or teachers in these examples may be independent of that of the strong quantifier in whose domain they appear overtly.)

- (6)a. Everyone reported that Max and *some lady* disappeared.
 b. Most guests will be offended if we don't invite *some philosopher*.
 c. All students believe anything that *many teachers* say.

In the cases of relative quantifier scope, as (6), the sentences are ambiguous and the judgment that the existential can have wide scope rests on intuitions regarding possible meanings of the sentence. Hence the facts in this area have been subject to many subtle considerations and debates, only some of which I will be able to mention here. For this reason, it is important to consider also *wh*-in situ and sluicing where no ambiguity is involved.

While in their semantics *wh*-in situ are standard existentials (a point I will return to), they enable us to examine the scope problem in a syntactic, rather than just semantic way. In this case, scope hypotheses can be directly tested (by the set of possible answers), and scope judgments usually rest on syntactic intuitions of well-formedness, which are much clearer than semantic intuitions regarding possible interpretations. Indeed, the substantial push for QR (and for LF theory) came, historically, from the findings of Huang (1982) who provided, for the first time, some content to the claim that movement is involved in assigning scope to *wh*-in-situ. At the same time, Huang pointed out that this assignment is not sensitive to islands. The scope of the italicized *wh*-in-situ in (7) is marked by the position of the top *who*, and it must, thus, be the whole sentence, even though the *wh*-in-situ are generated in the same island positions, as before.

- (7)a. Who reported that Max and *which lady* disappeared?
 b. Who will be offended if we don't invite *which philosopher*?
 c. Who believes anything that *who* says?

Turning to sluicing, illustrated in (8), the second conjunct in these structures has a *wh* NP as the 'remnant' of ellipsis. The first conjunct contains an NP corresponding to that remnant-'correlate'. The correlate NP can only be an existential one. So, this is a good test-case for existential distribution. The default assumption regarding their analysis, is that they must involve some operation in the first (antecedent clause). Following the spirit of the standard analysis of ellipsis (Sag, 1976; Williams, 1977; Pesetsky, 1982), an LF predicate has to be formed in this clause, which is obtained by applying QR to the correlate (*someone*), as in (8b).

- (8)a. They invited someone, but I forgot who.
 b. Someone_i [they invited e_i], but I forgot who
 c. Someone_i [they invited e_i], but . . . who_j [they invited e_j]

As for the second (sluiced) conjunct, two approaches are around: Either it is generated with an empty IP, into which this LF predicate is copied, or, under a deletion analysis, it is generated as a full sentence in which *wh*-movement applies. The second conjunct, under this analysis, looks, then, as in (8c). The predicates in (8c) meet the identity or parallelism requirement. So the second can delete either at LF, (as proposed by Sag), or at PF along the lines proposed recently by Chomsky. On the second view, the interpretation is based on the full derivation (8c), but since the predicate in the second conjunct is identical to the first, it is simply not pronounced.

Under both approaches, in any case, QR must apply to the existential in the first conjunct. Hence, sluicing is another case where the scope of the existential can be directly witnessed: If it cannot be extracted in the first conjunct, the second conjunct could not be interpreted, i.e., the derivation should be ill formed. However, as Chung et al. (1994) point out, already Ross has observed that whatever operation is involved here (prior to deletion), it violates all island constraints, as illustrated in (9), for the three sentence-structures we have been considering. The correspondent of the *wh* remnant is italicized in each case.

- (9)a. Max and *some lady* disappeared, but I can't remember which lady []
 b. If *a certain linguist* shows up, we are supposed to be particularly polite, but d'you remember who []
 c. Max will believe anything that *someone* will tell him, and you can easily guess who[].

1.3. Can the Problem with Existentials be Explained Away?

Summarizing what we saw so far, the original appeal of the QR analysis seems completely lost. First, the hope that scope is a unified phenomenon, reducible to syntax, is shattered by the fact that existential and strong quantifiers have completely different scope patterns. Next, if existentials do not obey island constraints, the type of movement required for scope is not reducible to standard syntax. In view of the graveness of the problem, let us look at some of the attempts made to explain it away, just to find out that it is, indeed, a real problem.

Interestingly, it is precisely in the case of existentials that it has ap-

peared, originally, least obvious that there is any real semantic problem of scope. A question which was debated in the seventies, at the dawn of QR, was whether it is true at all that the sentences of (6) are ambiguous, or whether it is indeed so obvious that wide scope should be encoded in any representation of these sentences. One line that was entertained then was that, in fact, to capture correctly the semantics of such sentences, it is sufficient to construe it with the representation with narrow scope of the existential. This is so since the (non represented) wide scope entails the narrow scope representation. That is, one of the situations which will render the construal of the existential with narrow scope true, is that in which its construal with wide scope is true. This, c.g. was the line taken in Reinhart (1976, 1979) and Cooper (1979). (An extensive survey of the debate regarding this issue can be found in Ruys (1992, Chapter 1).)

To illustrate this line, consider (10). The overt scope is as represented in (11a). Suppose our syntax allows only (11a), as the scope interpretation of this sentence. To show that this is not sufficient, and the scope representation in (11b) should also be derived for the sentence, we have to show that a possible use of the sentence is disallowed without this addition. The obvious way to show that is to find a context (model) in which (10) construed as (11b) is true, but (10) construed as (11a) is false.

(10) Every tourist read some guide-book

- (11)a. (Every tourist x (Some guide book y (x read y)))
 b. (Some guide book y (every tourist x (x read y)))

But this is impossible, since (11b) entails (11a). This should not be viewed as a proof that the sentence cannot have the reading (11b), but as an argument that there is no obvious way to know whether it does, or to distinguish between ambiguity and vagueness in such cases.

Compare this to the case in (12), repeated. Here overt syntactic compositionality allows only the representation (13a). Suppose our judgment is that the sentence can also be true when uttered in a situation where all guide books were read, but by different tourists. This cannot be accounted for without generating the additional representation (13b).

(12) Some tourist read every guide book

- (13)a. (Some Tourist x (every guide book y (x read y)))
 b. (Every guide book y (some tourist x (x read y)))

The problem here is the reverse of the previous one: The reading we generate entails the one we don't (but not conversely). This order of entailment is irrelevant for our purpose: Trivially, when A entails B (and B does not entail A), B can be true while A is false. Specifically, in the

situation under consideration, (13b) is true while (13a) is false. So there is no way to argue that (13b) represents just a specific instance which can make (13a) true. Since we decided that (12), nevertheless, can be true in a situation corresponding to (13b), the reading we generate is not sufficient.

The conclusion drawn from these entailment relations was that in the case of universal quantifiers, their wide, non-overt scope could not be explained away. It could only be derived by QR, or an equivalent generating the relevant scope construal. But in the case of existential quantifiers there is no genuine wide scope involved. Hence it would follow that while universal wide scope is restricted by constraints on movement, the apparent existential wide scope is not restricted syntactically.

However, it was soon observed that this entailment pattern holds only in a subcase of existential wide scope. Fodor and Sag (1982) and Ruys (1992) point out that even in the simplest cases, the argument does not hold when the existential occurs in the scope of a non-monotone quantifier. In this case neither scope construal entails the other.

- (14)a. Exactly half the boys kissed some girl.
 b. [Exactly half the boys x [some girl y [x kissed y]]]
 c. [Some girl y [exactly half the boys x [x kissed y]]]
 (15) Mary dates exactly half the men who know a producer I like.

For example, in Ruys' example (14), it is perfectly possible for the sentence to be understood as represented in (14c), with at least one (and the same) girl being kissed by exactly half the boys. But if the sentence is true under this construal, it may still be false under the narrow scope construal in (14b), e.g. if more than half of the boys kissed one girl or another, but only half kissed the same girl. Thus, if we generate only the overt-scope interpretation (14b), we do not capture correctly the conditions under which the sentence can be used truthfully. Nevertheless, existentials can take wide scope outside of an island also in such cases, as in Fodor and Sag's example (15).

Farkas (1981) and Abusch (1994) show the same in cases the existential occurs inside an implication, as in Farkas' (16), where the wide scope construal of *a poem* clearly does not entail the narrow construal.

- (16) John gave an A to every student who recited a difficult poem by Pindar.
 (17) If some relative of mine dies, I will inherit a house.

Similarly, in (17), it is very easy for the sentence to mean that there is a relative of mine such that if s/he dies I inherit a house, although this does

not entail that for any relative who dies this is so (the overt narrow-scope reading).

The facts are, thus, that when logic permits a clear differentiation of the two readings, they do indeed show up. This means that there must be some linguistic mechanism that generates the relevant readings. Even if the no-ambiguity line could have been maintained, somehow, for the issue of relative quantifier scope, it would be of no help with the other two problems of *wh*-in-situ and sluicing, since, as we saw, the free scope of existentials is witnessed there independently of any ambiguity. (For example, there is no possible independent local interpretation of the *wh*-in-situ that could entail the question interpretation.)

Another approach has been proposed to the apparent free scope of existentials. It rests on the fact that existential NPs (of the relevant type) can be used to refer to discourse entities, or to introduce new entities. On that view, developed in Fodor and Sag (1982), this is explained by assuming that indefinite NPs are ambiguous between quantified (existential) and referential interpretation. (In some views, this ambiguity is encoded as two entries of the indefinite determiner). In their free scope occurrence, indefinites are kind of referential. So, what seems to be ambiguity of scope construal of existentials is, in fact, just ambiguity of the indefinite NPs themselves. The idea that indefinites NPs are ambiguous has become popular recently (independently of the issue of free scope), and it comes under different names, each of which representing a slightly different view regarding what the relevant property is. On their referential side, indefinites can be Specific (Enç), D-linked (Pesetsky), Presuppositional (Diesing) or strong (de Hoop). It may appear that this view, unlike the previous one, could be extended to account for existential wide scope also in the case of *wh*-in-situ, as proposed at least for a sub-class of them by Pesetsky (1987). Hence we should examine it with some detail.

In this approach, then, there is no need to assume QR for the apparent wide scope of indefinites, since this is the reading obtained when they are used in their referential entry. Just as proper names can be interpreted in situ without moving – so goes this line – referential indefinites can also stay, with the same effect. Some variants of this line combine the idea of ‘specific’ or ‘referential’ indefinites with the mechanism of unselective binding: They do not function like proper names, but rather are bound in situ by a remote existential operator (Pesetsky (1987), Beghelli (1995).)

The obvious question these approaches face in the case of wide-scope existentials is how would one ever know whether indefinites are ambiguous or not. In the standard examples discussed in this literature, there can be no possible truth-condition difference depending on whether an existential

is construed as taking wide-scope or as specific, under any of the descriptions of specificity. (See Higginbotham (1987) for a more articulate presentation of this point).⁷ This, however, is not true for Fodor and Sag's (1982) analysis. Aware of this problem, they offer a clear way to check the distinction they propose. If the apparent wide scope interpretation is indeed generated by (island free) QR, we would expect all scope construals to be possible. Specifically, one of the construals that should be possible for (18a) is (18b).

- (18)a. Every professor will be fired if a student in the syntax class cheats on the exam.
- b. [For every professor *x* [there is some student *y* in the syntax class such that [if *y* cheats in the exam, *x* will be fired]]]

This construal is generated if QR raises the embedded existential out of the if-clause, but places it in the scope of the universal, which, if an island free QR is at work here, should be possible. But the claim is that the sentence does not allow this construal. (Though they do not spell it out precisely in this way, I think they mean the following:) If there happens to exist, say, one student who cheated in the exam, the construal (18b), allows the implication in (18a) to be true also in case some professors are fired and some are not: Every professor is associated with a student whose cheating will lead to firing. So many options are logically open if one student cheated, one of them is that one professor will end up fired. The factual claim of Fodor and Sag is that, in fact, the implication in (18a) is understood to be true only if either all or no professors are necessarily fired in this case. (Under the narrow scope construal, all professors should be fired if there exists a cheating student. Under the maximal wide scope it could be only all or none.) More generally, Fodor and Sag argue that we do not, in fact, get the full range of scope options but only two: The narrow (overt) scope, and a maximal wide scope, but no intermediate scopes. This is the result one would expect if the ambiguity at issue is between the logical (existential) interpretation of indefinites, and their referential one, which is simply insensitive to scope.

It is precisely correct that the two approaches to the relevant ambiguity problem, which we discussed so far, differ in this prediction regarding intermediate scope. What is extremely difficult, again, is to check the

⁷ Rather, the arguments for specificity readings usually rely on the authors' feelings regarding which previous discourse is more appropriate for each of the readings they propose for the sentence, or regarding the putative mental state of the speaker when he utters the sentence (e.g. the degree of his familiarity with the entity he talks about). All are, indeed, interesting and important pragmatic questions, but they are also highly undecidable.

intuitions needed to decide which is right. However, both Ruys (1992) and Abusch (1994) undertake this enterprise, and show with great care and detail that intermediate readings do exist. This is illustrated in (19a), from Ruys (his (18), p. 101).

- (19)a. Every professor_i will rejoice if a student of his_i cheats on the exam.
 b. [For every professor x [there is some student y of x such that [if y cheats on the exam, x will rejoice]]]
 c. [For every professor x [if there is some student y of x such that y cheats on the exam, x will rejoice]]

The pronoun here is bound by the universal, so there is no option for either maximal wide scope, or referential interpretation. Luckily, then, we only have two interpretations to consider, and Ruys argues that the sentence does indeed have both interpretations in (19b,c). Under the intermediate construal in (19b), the sentence can be true, even if, say, some student of Professor Jones cheats, and Professor Jones does not rejoice. (Professor Jones has two students, Max and Felix. Max has cheated, but Jones would have rejoiced if Felix had.) It may be easier to observe the intermediate readings if we use specificity markers – e.g. if we replace the indefinite in (19a) with *a certain student of his*. But what this means is that, as Ruys points out, the apparent specificity impression has nothing to do with either referentiality or maximal wide scope.

In the examples used both by Ruys and by Abusch for intermediate readings, the existential happens to contain a bound pronoun, as in *a student of his*, of (19a). Based on this fact, Kratzer (1995) argues that there are, in fact, no genuine intermediate readings of existential wide scope in such contexts, but it is the pronoun which creates an impression of such readings. She offers a mechanism for capturing the anaphora interpretation in such cases (which is probably needed, independently, for this and a variety of other anaphora problems, also in the system I will proceed to propose). With this assumed, she proposes a new implementation of the basic intuition of Fodor and Sag that the apparent existential wide scope is a case of specificity, relating to the discourse status of the indefinites.

However, intermediate readings have been noted and analyzed before, also without bound pronouns. Farkas (1981), brings the following counter-examples to Fodor and Sag's claim. (Her (17), p. 64).

- (20)a. Each student has to come up with three arguments which show that some condition proposed by Chomsky is wrong.

- (20)b. Everybody told several stories that involved some member of the Royal family.

In (20a), it is relatively easy to understand the three arguments as addressing one and the same condition by Chomsky, but still the relevant condition may vary with students. (Namely *some condition* has wider scope than *three arguments*, but narrower than *each student*). Admittedly, in these examples one could argue that the impression that it is the same condition for all three arguments is just a matter of vagueness, along the entailment-line we examined above, and that hence, this is not an intermediate reading, but just a specific instance which makes the narrowest scope of *some condition* come true. To control for this, we may look at (21), based, with some variation, on the inventory of Ruys.

- (21)a. Most linguists have looked at every analysis that solves some problem.
 b. [Most linguists]₁ [[some problem]₃ [every analysis that solves e₃]₂ [e₁ looked at e₂]]
- (22) Each student has to find all arguments in the literature which showed that some condition proposed by Chomsky is wrong.

Let us focus on the reading where *some problem* in (21) has scope wider than *every analysis*, namely, for a given problem, the relevant linguists looked at all the analyses that solve this problem. It is still possible, in this case, that different linguists looked at different problems. That is, it is not a necessary entailment that most linguists looked at the analyses of the same problem. This, then, is the intermediate reading represented, syntactically, in (21b). (But obtaining this reading syntactically would involve extraction of the indefinite out of an island.) Similarly, the modification of Farkas example in (??), still allows the intermediate reading, so the sentence is three-ways ambiguous.

The same point can be illustrated in the sluicing context (23). The most plausible construal of the elliptical part (following *which word*) is as given in the brackets in (23b). Given our assumptions so far, this construal can only be obtained if the correlate *some word* occurs (at the covert structure) in an intermediate position between *each player* and *all the consonants*.

- (23)a. Each player must write down all the consonants that some word contains, when properly pronounced, and let the others guess which word.
 b. Each player x must. . . let the others guess for which word y, [x wrote down all the consonants y contains when properly pronounced].

We may conclude that intermediate readings are available, independently of whether a bound pronoun occurs or not. The presence of a bound pronoun, as in (19a), only makes it easier to observe the existence of the intermediate reading, since it eliminates one of the competing readings – that of widest scope. (The more available all three readings are, the hardest it is to identify just the intermediate one.) As always with tasks involving quantifier-interpretation, judgments of such readings may be subtle, and certainly depend on many contextual factors. But it is sufficient that there are contexts where they are possible to raise the question how they are derived. Fodor and Sag's test has provided us, then, with further confirmation of the conclusion that there is a real problem here. Existentials show properties that (so far) look like logical wide scope, with blatant blindness to islands.⁸

1.4. *The 'Realistic' QR View of the Eighties*

The problem we observed, then, is that existential and universal quantifiers appear to have completely different scope options. The first clearly obey island restrictions, and in many cases have narrower scope options than predicted by QR; the second have broader options than predicted by QR. So it does not seem that the original optimism of the QR view can be maintained. In the view of QR that emerged in the eighties, this problem was addressed. The decisive factor was Huang's (1982) argument that although *wh*-in-situ do not obey subjacency islands, there is evidence that they nevertheless must move to get scope (since they obey another syntactic condition – the ECP, an issue I will return to, in Section 2.4). The theoretical account that emerged, then, is rather complex (Huang (1982), May (1985), Chomsky (1986)): First, the idea that QR is just an instance of standard syntactic movement (move α) was replaced by the assumption (24a) that QR is a special operation, not restricted by subjacency islands. Or, put differently, that subjacency only restricts overt syntactic operations, but not the covert ones. This entails directly the distribution of existentials, but raises the question why strong quantifiers are so

⁸ A more formal implementation of Fodor and Sag's intuition is offered in Beghelli, Ben-Shalom and Szabolcsi (1993). They apply the concept of a principal filter which, intuitively, enables the quantifier to "always talk about the same individuals". While universal and definite NPs always denoted principle filters, indefinites may do so, as an additional reading. With this assumed, the apparent wide scope in the relevant cases follows, in an interesting way, as an entailment of the logical scope construals of the sentence. They do not discuss the problem of intermediate readings. So it remains to be studied if the analysis could be modified to handle those.

restricted. For that, it was decided that a further restriction applies to them, which, as far as I know, was not actually defined beyond the statement that it is 'roughly clause-bound', as in (24b). The modification '*roughly*' is interpreted sometimes as allowing also extraction out of ECM and infinitival clauses.⁹

(24) *The QR view in the eighties*

- a. QR does not obey subjacency islands.
- b. Strong quantifiers are 'roughly' clause-bound.

Technically, it can be argued, then, that QR is one unified rule, but since strong quantifiers are further restricted, they never get a chance to manifest the full options of QR.

We should note that the problem-solution ratio here is rather poor. The problem is that we discovered three types of scope taking options: overt *wh*-movement, which is island restricted, covert scope of existentials, which is island-free, and covert scope of universals which is island restricted, or perhaps more restricted than that, and we wondered why this is so, namely, what generalization(s) this could follow from. The solution is that there are three rules each capturing exactly one of these options. They do not capture anything beyond just these three problems, since, except for the scoping of existentials, there is no other movement operation which does not obey subjacency, and except for the scoping of universals, no other movement is restricted in the 'clause-bound' manner.¹⁰ In other words, the solution is nothing more than rephrasing the description of the problem in a more technical language. Although I focused here on the QR approach, the ratio problem remains the same for all approaches to scope that share this view of what the facts are, though the technical language of the description may vary dramatically.

If this is how things are, the early optimism must be replaced with a modest and realistic approach. The question, though, is whether this new picture is, indeed, realistic. Do we, at least, manage to describe correctly the facts? Of course, if we don't, more problem-specific rules can be

⁹ Recently, several syntactic accounts for clause boundedness have been proposed. In Hornstein's (1994) elegant solution, wide scope of strong NPs does not require movement at all. Rather the scope is determined by which element of an A-chain gets deleted. However, since this allows wide scope only in A-chain environments, it allows ECM and raising subjects to take wide scope outside their clause, but it excludes wide scope out of infinitival clauses, which is widely believed to be allowed (see Ruys (1992) and Beghelli (1995) for the facts). Beghelli's (1995) account captures scoping out of infinitivals, and many other facts, but at the price of employing much heavier machinery than Hornstein's

¹⁰ Extraposition is supposed to be clause bound, but a growing consensus is that it does not exist, as a syntactic operation.

added. However, if we don't have any upper bound in our theory on the number of stipulations and lists we can add to address every new problem, it is possibly true that we can reach a correct description, or at least the opposite cannot be easily proven, but it is a mystery how a language learner can learn such lists of descriptions.

1.5. *Some Problems*

Some (relatively minor) problems arise regarding the proposed generalization in (24b) that strong quantifiers are clause-bound. One of the problems that QR seemed particularly promising for, e.g. in the analysis of May (1977), was the *de re* interpretations in belief contexts, as in (25a).

- (25)a. Lucie believes that every politician is corrupt.
- b. Someone believes that every politician is corrupt.
- c. Someone is always willing to believe that every politician is corrupt.
- d. [someone]_i [everyone]_j [e_i believes that e_j is corrupt]

Under its *de re* interpretation, (25a) entails that Lucie believes that Clinton is corrupt, and the standard way to guarantee this entailment is by scoping the universal out of its clause. If (24b) is correct, this is no longer permitted. Possibly, some way can be found to capture *de re* interpretations without movement, but for the time being, it seems that this entails adding problem-specific stipulations.

Nevertheless, it is still the case that in (25b), it is very difficult to get a reading where *someone* is dependent on, namely in the scope of, *every politician* (slightly easier in the generic (25c)). This is the intuition that (24b) is based on. It seems that the scope construal we can easily get is that represented syntactically in (25d), where *every politician* scopes out of its clause, hence interpreted *de re*, but still has narrower scope than *someone*. It is not obvious why this is so, but it is just as possible that it is because *someone* in such contexts resists referential dependence, and not because *every politician* resists taking wide scope.¹¹

Recall that the problem which led to the decision (24b) was that strong quantifiers present a mysterious behavior, when it comes to questions of their scope interaction with other quantifiers. It is sometimes easy and

¹¹ Hornstein (1994) proposes a principle, inspired by Diesing (1992), which he labels 'reference principle', which has the effect that when NPs of the 'specific' type (i.e. the set of existentials under consideration) occur in subject position, they always prefer wider scope than their competitors. (Though the principle is stated in a different terminology).

sometimes difficult for them to get scope wider than quantifiers that c-command them overtly, inside or outside their clause, and, in fact, we don't know when and why. Thus, in (1c), repeated, *every new patient* can easily take scope over the higher subject, contrary to (24b), though I don't know why.

- (1)c. A doctor will make sure that we give every new patient a tranquilizer.

When an irregular pattern of facts is discovered, it is always only the theory that could decide what is the rule and what is the exception. The decision to adopt (24b) and leave out (25a) and (1c) as unexplained problems, has no merits over the opposite decision, to take these two as representing the standard application of QR, and leave the question why it is sometimes much harder (as in (25b)) for future explanation.

However, (24b) does not pose serious conceptual problems, in and of itself, so we may leave the question whether it is indeed motivated open here.

The major conceptual problem with the description in (24) is the assumption that the covert operation, OR, differs from overt movement in that it does not obey subjacency. Already in the first stages of this theory, opinions divided sharply regarding the status of such statements. Some thought that this is a real hindrance to a unified theory of syntactic movement. Others thought that the fact that syntactic movement and LF movement obey different constraints is a strong evidence for LF, as distinct from SS. While this, purely conceptual, debate could go on for ever, in the minimalist program it is impossible even to state this question, since there are no levels. There is only one derivation – deriving LF – which can be spelled out and enter the PF interface at any stage, but there is no way to state that up to the branching to PF you have to obey a certain constraint, and from there on – not.

Independently of the conceptual issue, it is also empirically wrong that covert movement in general does not obey subjacency. The discussion here focused on the issue of relative scope of quantifiers. But there are several other problems that have motivated QR over the years. In the case of comparatives, like (26a), virtually all analyses assume that *men* must scope out, covertly, at LF (along with some degree operator; Heim (1986) provides an extensive survey of available approaches). But the way QR operates in this case parallels the operation of overt scoping: It is not clause bound – in (26b) the NP *Clinton* can easily be extracted out of its clause, to form the comparison pair with *Dole*. Yet, it obeys subjacency

– for (26c) to be interpretable, *Bach* must be extracted, but since it occurs in an island, this is impossible, so the derivation is uninterpretable.¹²

- (26)a. We invited more men to our party than women.
 b. More people said that they will vote for *Clinton*, in the last pole, than for Dole.
 c. *More people who love *Bach* arrived, than Mozart.

Another instance is *except* elliptic conjunctions, as in (27). Here too, the italicized (correlate) phrase must move at LF. (This is argued in detail in Reinhart (1991), where I argue also that no overt syntactic movement can account for such structures.) This case is particularly interesting, since the NP moved here is a universal quantifier. Still, this movement is not clause-bound, as illustrated in (27b), but it does obey subjacency. The derivations (27c), where the correlate is in an island, hence its LF movement violates subjacency, are as bad as the cases of overt movement such as (27d).¹³

¹² Currently, a leading hypothesis regarding VP ellipsis is that it does not involve LF copy, but rather some mechanism of actual deletion at PF, under a parallelism condition. However, it is hard to see how an equivalent can be developed for comparatives, without scoping out at least the degree operator. Even if a PF deletion approach could be developed for the comparative cases, they still differ from VP ellipsis, since the latter does not show island effects as those illustrated in (26c). Thus, such an analysis would have to involve some scoping of the correlate in the first comparison clause. For the *except* cases below, an ellipsis analysis is infeasible, anyway (see the next footnote).

¹³ I argue in Reinhart (1991) that an ellipsis approach (whether copy or deletion) is impossible for these structures, since it yields the wrong semantics. (ia) cannot be derived from anything like (ib). Even if we sneak in the negation mysteriously, as in (ic), (ic) is a contradiction, which (ia) is not.

- (i)a. Everyone arrived, but Felix.
 b. #Everyone arrived, but Felix arrived.
 c. Everyone arrived, but Felix did not arrive.
 (ii) Everyone but Felix arrived.

In its interpretation, (ia) is identical to (ii), where *every-but* is one constituent. It could appear that (ia) could be derived by some overt movement applied to (ii). However, I argue there, that if we look at the full distribution of *except* conjunctions, this turns out an impossible analysis. Current syntactic theory entails certain differences between overt and covert movement, since the overt one is via SPEC CP, while the covert one is by adjunction. For example, while syntactic movement shows *wh*-islands, as in (iii), it has been noted (c.g. in Moltmann and Szabolcsi (1994)) that there are no such islands with covert movement. *Except* conjunctions are, indeed, insensitive to *wh*-islands, as in (iv). The same is found with the movement of the correlate in comparatives, as in (v).

- (iii) *About whom should I tell you what I think *e*?
 (iv) I'll tell you what I think about *everyone*, if you insist, except my boss.
 (v) More people remember what was said by Clinton than by Dole.

For this, and other reasons, I argue that the semantic *every-but* constituent in such structures must be formed at the covert structure.

- (27)a. We invited *everyone* to our party, *except/but* Felix.
 b. Lucie admitted that she stole *everything*, when we pressed her, *except/but* the little red book.
 c. *The people who love *every composer* arrived, *except/but* Mozart.
 d. *Which composer did the people who love *e* arrive?

If other instances of QR do obey subadjacency, the description of the problem in (24) cannot be maintained. Rather, we should go back to a more elementary statement of the mystery we started with: Existential NPs can move arbitrarily to get wide scope. This needs now to be stipulated as a purely problem-specific operation. In Section 4, we will see that even so, this is not the correct description of the problem. The wide scope generated by such island free movement is not, actually, found in English, and allowing such rule to exist yields the wrong semantics.

But even if it was the correct description, it would still make sense to look for something from which it could be derived. The alternative, which has been considered all along, is that the wide scope of existentials can be captured in-situ (i.e. without movement), and could follow from some independent properties of these NPs. Let us now consider these alternatives. We will see that although syntactically and conceptually, there is strong reason to believe this is the right direction, (Section 2), the actual implementations of this idea fail dramatically to capture correctly the interpretation of existential wide scope (Section 3).

2. THE ALTERNATIVE OF WIDE SCOPE IN-SITU

2.1. *Wh-in-situ*

As I mentioned, *wh-in-situ* illustrate best the free distribution of existential scope (since their scope is directly tested by the set of possible answers). But at the same time, they also illustrate an alternative line for accounting for this scope, which does not involve movement. In fact, the history of this problem within the syntactic frameworks goes back and forth between the two approaches. The one, which I assumed in the previous discussion, is that they undergo movement at LF, to some clause-initial position, where their scope is correctly captured, as illustrated, for (28), in (29a). The other, originating in Baker (1977), is that each question-sentence contains an abstract Q-morpheme, and *wh-in-situ* are bound directly by Q. (More generally, the idea that scope assignment does not require movement was advocated in several papers by Williams, though along somewhat different lines (c.g. Williams (1986).) This view has regained

popularity and got further developed in the work of Pesetsky (1987) and Nishigauchi (1986), who argued that at least in certain cases, *wh*-in-situ are bound in situ by Q. Their formulation of this line, makes use of the mechanism of unselective binding developed in Heim (1982). The Q operator unselectively binds all the variables in the *wh*-NPs which have not moved. The IF derived this way for (28) is (29b). If this line is adopted, the island problem is directly resolved: *wh*-in-situ are insensitive to islands since they never move (and coindexation is insensitive to islands, anyway).

- (28) Which lady₂ [e₂ read which book₁]?
 (29)a. I.F-movement: [Which book₁ [which lady₂ [e₂ read e₁]]]
 b. Baker(77): Q <_{1,2}> [which lady₂ [e₂ read which book₁]]

Although, as we shall see, it is far from obvious how the available analyses along the lines of (29b) can yield the correct semantics, the reason why they were rejected in the QR framework is syntactic, rather than semantic.

Huang (1982) noted contrasts like those in (30)–(31). In (30a), with an argument *whom* in situ, the derivation is fine, even though a *wh* cannot move overtly out of this position, as seen in (30b). But if the adverbial *how* occurs in this position, as in (31a), the derivation is uninterpretable. Syntactically, the difference is that *how* is an adjunct rather than an argument. Generally, adjuncts are assumed to be more restricted in their options of movements than arguments, since they need to obey also the syntactic condition known as ECP.¹⁴ If we assume *wh*-in-situ have to move covertly to get scope, then the illformedness of (31a) follows from the ECP, in the same way that the overt movement in (31b) is ruled out.

- (30)a. Who fainted when you attacked whom?
 b. *Whom did Max faint when you attacked e?
 (31)a. *Who fainted when you behaved how?
 b. *How did Max faint when you behaved e?

This, along with parallel facts from Chinese (which has no overt *wh*-movement at all), was taken as decisive evidence that QR must apply to assign scope of *wh*-in-situ, since this scope is sensitive to purely syntactic

¹⁴ Roughly, the ECP (Empty Category Principle) states that if the moved constituent is not a complement of some predicate, then there can be no syntactic barrier between it and its trace. This entails that when an argument is extracted across a syntactic barrier (i.e. out of an island) it violates only subadjacency, but when an adjunct is extracted from the same position it violates both subadjacency and the ECP. Correspondingly, it is also assumed that (31b) is worse than (30b), since it violates two syntactic conditions.

constraints. But at the same time, it led to the conclusion that QR is not sensitive to subjacency, to account for (30a).

A fact that was overlooked, though, is that it is only the adverbial *wh*-adjuncts which behave as in (31a). (32a), where *how* is replaced with *what way* is fine. Syntactically and semantically *what way* is an adjunct, just as *how*. Indeed, its overt extraction in (32b) is just as bad as in (31b). If the ECP is what rules out (31a), there is no way to explain why it does not do that also in (32a).¹⁵

- (32)a. Who fainted when you behaved what way?
 b. *What way did Max faint when you behaved e?

The question posed by (31a) is what makes the scope of adverbial *wh* appear more restricted, but it cannot be viewed as evidence of movement. Indeed, in the minimalist program of Chomsky (1995), the idea that *wh*-in-situ move covertly was abandoned. I discuss this issue in detail in Reinhart (1994), where I also suggest an account for the peculiar behavior of adverbial adjuncts like *how*.

2.2. *Sluicing*

We may turn now to sluicing, under the new light that Chung, Ladusaw and McCloskey (1994) have shed on these structures. As noted in the discussion of (8)), repeated in (33a), under all standard analyses, an LF predicate is formed by QR in the antecedent clause, as in (33b) (following Sag and Williams). On the LF copy view, this predicate is copied (covertly) into the empty IP of the second (sluiced) conjunct. On the alternative view of ellipsis as deletion under identity at PF (proposed by Chomsky), it seems that *wh*-movement should also apply in the second conjunct, and then the two IPs are identical, and the second can be deleted.

- (33)a. They invited someone, but I forgot who.
 b. Someone_i [they invited e_i], but . . . who_j [they invited e_j]

¹⁵ The ECP generalization fails also in many other cases. It should apply also to subjects and not just to adjuncts. Thus, the syntactic extraction in (iib) has all the marks of a severe ECP violation, still its *wh*-in-situ counterpart is perfectly fine.

- (i)a. Who read the book that who wrote?
 b. *Who did Max read the book that e wrote?

- c. Max and *some lady* disappeared, but I can't remember who []
- d. If *a certain linguist* shows up, we are supposed to be particularly polite, but I d'you remember who []
- e. Max will believe anything that *someone* will tell him, and you can easily guess who.

The problems posed by the islands violations illustrated in (7), repeated in (33c–e), is even more acute than in all other cases. Under both views of ellipsis, there does not seem to be a way around assuming some movement, in the first conjunct, since it is only this movement that creates identity between the two conjuncts. (If, at the deletion stage we have the structure: *They invited someone but I forgot who they invited t*, nothing licenses deletion of the second IP). If my presentation of the second view is correct, then this seems to also require violation of subadjacency of the overt *wh*-movement in the second conjunct. (This, indeed, was what Ross (1969), who discovered these structures and named them 'sluicing', assumed to be the problem.)

A long standing puzzle is the fact that only indefinite (existential) NPs can license sluicing: Sluicing in the second conjunct is possible only if the 'correlate' of the *wh*-phrase in the first conjunct is existential. That is, it is impossible in (34a) and (35a), where the (italicized) correlate is a strong NP.

- (34)a. *Lucie knew already that they appointed *Max*. Still, she didn't tell me who.
- b. Lucie knew already that they appointed Max. Still, she didn't tell me who they appointed.
- (35)a. *If you know already that *everyone* objected to your proposal, there is no point in asking who.
- b. If you know already that everyone objected to your proposal, there is no point in asking who did.

Chung et al. point out that this restriction on the possible correlate cannot be dismissed as falling under some pragmatic considerations. As they show with similar examples, the discourse in (34) and (35) is perfectly coherent. That this is so, is further witnessed by the fact that without the ellipsis the sentences are fine, as in the (b) cases. In (35b) we also see that there is no independent ellipsis problem here, since VP ellipsis is possible. Whatever makes the (a) case impossible must then be syntactic and not pragmatic.

It may appear that this could follow from the standard picture of QR, summarized in (24): Since existentials do not obey subjacency, they may scope out in (33c–e), but strong quantifiers are restricted to their clause, hence they cannot scope out in (34)–(35). But this is not the correct account. Strong NPs do not license sluicing also when they are not embedded, as in (36a).

- (36)a. *We invited everyone you know to the party, so stop asking me who.
 b. We invited everyone you know to the party, so stop asking me who we invited.
 c. [Everyone you know]_i [we invited e_i to the party] . . .

Under the standard picture, nothing prevents QR of *everyone* within its own clause, as in (36c), which should, then, license the sluicing in the second conjunct. Nevertheless, sluicing is impossible. Again, this is not a pragmatic, or contextual matter, since (36b) with the same intended meaning is *fine*. Why only existentials can license sluicing remained, thus, a persistent mystery.

Chung et al.'s alternative analysis explains both the subjacency question and the indefiniteness effects. It rests on the basic idea in DRT (Kamp, Heim) that indefinites are not necessarily closed NPs, but they can be viewed as 'restricted free variables'. As in Heim (1982), their variable can, then, be unselectively bound by another operator. They propose, then, that given a structure like (37a), an operation which they call 'merging', applies: the full antecedent IP is copied (recycled) as is into the second clause, yielding (37b).

- (37)a. They invited some linguist but I forgot who
 b. They invited some linguist but I forgot who [they invited some linguist]
 c. . . . but I forgot [which x [they invited linguist (x)]]

The indefinite determiner (*some*) is, as just noted, semantically invisible, hence the indefinite variable in the recycled IP can now be unselectively bound by the *wh* operator. Simplified, the result is illustrated in (37c). (I will return to the question how the merging operation is interpreted.) Since merging involves unselective binding, the indefiniteness effect is derived: If a clause containing a strong NP gets 'recycled', this NP cannot be unselectively bound, so the *wh* operator will not bind any variable, and the derivation is ruled out as vacuous quantification (an illegitimate LF object). The island problem also disappears. No movement is involved

at all, and unselective binding is not island sensitive (just as assumed before for *wh*-in-situ).

While in the case of *wh*-in-situ, the evidence against movement analysis was subtle, as we saw, here it is fully decisive. The existential-specific version of QR, which does not obey subadjacency, can describe correctly the fact that islands are not observed in the sluicing examples, but there is no way it can explain or describe the definiteness effect, namely, why only IPs containing an existential can serve as the antecedent clause of sluicing. There is also additional strong evidence for Chung et al.'s approach in their paper.

3. THE INTERPRETATION PROBLEM OF WIDE-SCOPE IN SITU

We saw some of the advantages of giving up the idea of obtaining wide existential scope by movement. However, a crucial question which should be checked is whether an interpretation which captures truth conditions correctly can be associated with the structures we generate. The island-free QR seems, so far, to face no problems in this area, which is why it was proposed, to begin with. (Though, as we shall see in Section 4, this is not true either.) The question, then, is whether the alternative can capture this one and only thing which the previous analysis appears to do right.

As we saw, the mechanism which made it possible to account for wide existential scope with no movement is assumed to be unselective binding. So far we followed this line in the case of *wh*-in-situ, and sluicing, but it has been proposed also for the interpretation of wide scope, most explicitly by Beghelli (1993). We should note, though, that the use of this option here is dramatically different than in Heim's (1982) original proposal. Heim did not allow unselective binding across an intervening operator, and more generally, the indefinite could only be unselectively bound in a position obtained by QR. So, she assumes both island-free QR and unselective binding. This is with very good reason, as will become obvious soon. So, we should check now if it is indeed possible to extend this mechanism in the proposed way. Or, more generally, do we capture correctly the semantics of wide scope, without QR?

As before, I will first examine this question in detail in the case of *wh*-in-situ, where the judgments are clearest. Then it will be easy to see that we are facing precisely the same problem in all three areas of existential wide scope under consideration here. (The argument regarding the *wh* cases appeared in Reinhart (1992).)

3.1. *wh-in-situ*

Let us assume here the semantics of questions proposed by Karttunen (1977) (see also Engdahl (1986)).¹⁶ On this view, *wh*-NPs are, essentially, existential NPs, and the question denotes the set of propositions which are true answers to it. For example, the interpretation of question (38a) is given in (38b).

- (38)a. Which European country has a queen?
 b. $\{P \mid (\exists x) (\text{European country } (x) \ \& \ P = \wedge(x \text{ has a queen}) \ \& \ \text{true}(P))\}$
 c. $\{\text{England has a queen; Holland has a queen}\}$

(38b) is the set of true propositions P , such that there is a European country x about which P asserts that x has a queen. In our actual world, the values of x yielding 'x has a queen' as a true proposition turn out to be England and Holland, so the question denotes the set in (38c). It should now be obvious why *wh-in-situ* pattern with all other existential NPs – being standard existentials, their distribution is just like that of the other existential NPs.

Recall that the two LF's we have been considering for the syntax of (28) are those in (29), repeated.

- (28) Which lady₂ [_{e₂} read which book₁]?
 (29)a. QR – movement: [which book₁ [which lady₂ [_{e₂} read e₁]]]
 b. Unselective binding: $Q_{\langle 1,2 \rangle}$ [which lady₂ [_{e₂} read which book₁]]
 (39)a. Which lady read which book?
 b. *With movement*: $\{P \mid (\exists x)(\exists y) (\text{lady } (y) \ \& \ \text{book } (x) \ \& \ P = \wedge(y \text{ read } x) \ \& \ \text{true}(P))\}$
 c. *No movement-'unselective binding'*: $\{P \mid (\exists \langle x, y \rangle) (\text{lady } (y) \ \& \ P = \wedge(y \text{ read } x \ \& \ \text{book } (x)) \ \& \ \text{true}(P))\}$

Applying Karttunen's analysis to the two LF's, we get (39b) for the LF obtained by raising of the *wh-in-situ*. (This is the set of true propositions P such that there is a lady y and a book x , about which P asserts that y read x .) (29b) – the representation obtained with no covert movement of the *wh-in-situ*, corresponds now to (39c), which differs from (39b) only in where the *book*-restriction occurs in the representation.

If *wh-in-situ* don't move, a crucial result of the analysis is that although their scope is identical to that of a moved *wh*-phrase, the N-restriction

¹⁶ I chose this framework since it lends itself easily to the type of solution I propose for the problems below. I leave it open whether the same can be stated also in the framework of Groenendijk and Stokhoff (1982).

stays in situ, rather than occurring as a restriction on the question operator. In the specific case of (39), the result is unproblematic. The two representations appear equivalent. But if we look deeper, we will discover that this is, nevertheless, the wrong interpretation, and the idea of leaving the restriction in situ is rather dangerous.

To see this, let us consider (40). (For convenience, I will use both an informal representation, and Karttunen-type representations in the examples.)

(40) Who will be offended if we invite which philosopher?

WRONG:

(41)a. For which $\langle x, y \rangle$, if we invite y and y is a philosopher, then x will be offended.

b. $\{P \mid (\exists \langle x, y \rangle)(P = \wedge((\text{we invite } y \ \& \ \text{philosopher}(y)) \rightarrow (x \text{ will be offended})) \ \& \ \text{true}(P))\}$

c. Lucie will be offended if we invite Donald Duck

RIGHT:

(42)a. For which $\langle x, y \rangle$, y is a philosopher, and if we invite y , x will be offended.

b. $\{P \mid (\exists \langle x, y \rangle)(\text{philosopher}(y) \ \& \ P = \wedge((\text{we invite } y) \rightarrow (x \text{ will be offended})) \ \& \ \text{true}(P))\}$

In this case, the restriction occurs in an if-clause. So, the representation obtained if we leave it in situ is (41a). Now, if (41a) is the question expressed by (40), one of the possible answers to it should be (41c). Since Donald Duck is not a philosopher, it must be true of him that if he was a philosopher and we invited him, Lucie will be offended.¹⁷ In fact, any thing which is not a philosopher could be a value for y in (41a), since its restriction occurs in the antecedent clause of an implication. This result is just wrong. We do not want to allow (41c) in the set of possible true answers to the English question (40).¹⁸ The representation yielding the

¹⁷ Technically speaking, it is not, in fact, fully clear that the representation (41b) should allow the relevant answer to be (41c). It allows Donald Duck as a value for y , but the proposition in the denotation set may have to be (i). If this is so, however, (41b) would also disallow (ii) as a possible answer, while equally allowing both (i) and (iii) as answers, which is sufficiently wrong.

(i) Lucie will be offended if Donald Duck is a philosopher and we invite him.

(ii) Lucie will be offended if we invite Kripke.

(iii) Lucie will be offended if Kripke is a philosopher and we invite him.

¹⁸ A reviewer pointed out that the analysis in (41) cannot be rescued by employing an actuality operator on the restriction, as, say in (i).

(i) $\{P \mid (\exists \langle x, y \rangle)(P = \lambda w ((\text{we invite } y \text{ in } w \ \& \ y \text{ is a philosopher in the actual world}) \rightarrow (x \text{ will be offended in } w)) \ \& \ \text{true}(P))\}$

correct set of answers in such cases is that in which the restriction is pulled out of the implication, as in (42a). This correctly allows the values for y to be all and only those individuals who are philosophers and for whom the implication is true.

The same problem is illustrated with (43). Leaving the restriction in situ and applying unselective binding, we obtain (43b), under which it turns out that a necessarily true answer is e.g. (43d), since it is true for every linguist x that if Nancy Reagan is a philosopher, then x read every book by her.¹⁹

- (43)a. Which linguist read every book by what philosopher?
 b. For which $\langle x, y \rangle$, x is a linguist and for every z , if z is a book by y and y is a philosopher, then x read z .
 c. $\{P \mid (\exists \langle x, y \rangle) (\text{linguist}(x) \ \& \ P = \wedge (\forall z (\text{book by } y(z) \ \& \ \text{philosopher}(y)) \rightarrow (x \text{ read } z))) \ \& \ \text{true}(P))\}$
 d. All linguists read every book by Nancy Reagan.

The same problem with leaving the N restriction in situ shows up in all areas of existential wide scope.

3.2. *Sluicing*

As we saw, Chung et al.'s (1994) analysis of sluicing is, probably, the first real solution ever proposed to this problem. However, it rests on precisely

The same problem remains in (i), namely that any non philosopher in the actual world satisfies the implication.

¹⁹ It is fashionable nowadays to enrich both the semantic and syntactic machinery by associating presuppositions with almost any type of NP. This line of thinking would attempt to face this problem by claims that *wh*-phrase carry presuppositions, and it is the presupposition of *what philosopher* which should somehow explain why the wrong answers obtained by the derivations above are excluded. Associating presuppositions with existentially quantified NPs is highly problematic within any of the familiar semantic systems, as it disables basic entailments. Semantically, *wh*-expressions are strictly existential (weak) NPs. This claim cannot even be evaluated under Karttunen's analysis, which I assumed here only because it is most familiar, and because of the fine details are irrelevant to my main argument. For example, if *wh*-expressions are weak, the question *How many chairs in this room are broken?* should be equivalent to the question *How many broken chairs are there in this room?* But under Karttunen's analysis, the definition of P in the set of propositions will be entirely different for these questions, so equivalence cannot even be computed. However, this problem does not arise in the original analysis of Hamblin (1976), where the restriction is put inside the definition of P . This captures correctly what I believe to be the semantic properties of *wh*-expressions. Hamblin himself is quite explicit about the issue of presuppositions belonging to pragmatics (Hamblin, 1976, p. 257).

In any case, even if *wh*-expressions are always presuppositional, we would still need to know how, precisely, this "somehow" association between presuppositions and the wrong

the same idea of extending the mechanism of unselective binding. It is easy to observe that it will therefore face the same interpretation problem.

Recall that Chung et al. argue that the antecedent IP of, e.g. (44a) is recycled into the sluiced conjunct, yielding (44b). This now is interpreted by unselective binding. The authors do not specify exactly how this happens, but exemplify the intended output of this operation, which is (44c). Namely, (44b) is to be interpreted as the standard question (44d), which is indeed precisely what we want.²⁰

- (44)a. Joan ate dinner with some linguist, but . . . with whom.
 b. [with whom] [Joan ate dinner with some linguist]
 c. $\{P \mid (\exists z) (\text{linguist}(z) \ \& \ P = \wedge(\text{Joan ate dinner with } z) \ \& \ \text{true}(P))\}$
 d. With which linguist (did) Joan eat dinner e?

But the crucial question is still, how we get from (44b) to (44c). In (44c), the N restriction *linguist* is pulled out, to the restrictive term of the *wh* (existential) operator. A standard way to do that, is apply QR to *some linguist*, as indeed Heim (1982) does in her analysis of unselective binding. However, as we saw, a central point in Chung et al.'s analysis is that sluicing structures defy subjacency, and one of their breakthroughs was in enabling us to avoid an island free QR.

- (45)a. If *a certain linguist* shows up, we are supposed to be particularly polite, but do you remember who []?
 b. Max will believe anything that *some teacher* will tell him, and you can easily guess who.

The island-blindness of these structures was illustrated in (9), repeated in (45). If QR obeys subjacency, the italicized indefinite cannot move, after merging. Specifically, its N-restriction will stay in situ (or, at most, be attached to the lower clause). To interpret the derivation, we may attempt unselective binding in situ. But then, we run into precisely the same problem as before. For example, after merging, the second conjunct of (45a) is (46a). Allowing the *linguist*-variable to be unselectively bound in situ by the question operator, will yield the interpretation informally represented in (46b).

entailments under consideration is executed, beyond the hope that this problem could somehow be solved.

²⁰ My presentation of Chung et al.'s analysis is based on a pre-published version of the paper.

- (46)a. . . . who [if a certain linguist shows up, we are supposed to be particularly nice]
- (46)b. For which x , if x shows up and x is linguist, then we are supposed to be particularly nice.
- c. It is Donald Duck, obviously!

This, again, is an interpretation which the sentence lacks altogether. If it had this interpretation, we could have happily let Donald Duck be our reply, as in (46c), which we obviously cannot. The same considerations apply to (45b), which is precisely analogous to (43), as far as the semantic problem goes. So, if this semantics is correct, I would have been perfectly justified in volunteering Donald Duck, again, as my guess for who Max will believe.

3.3. *Existential Wide Scope*

Recall that the original problem of wide scope for which the island-free QR was assumed is that of quantifier scope, discussed in detail in Section 2. It may appear that these cases lend themselves most easily to the solution of unselective binding, since that mechanism was proposed, to begin with, in order to allow indefinites to be externally bound either by the standard existential operator, or by what DRT introduced as a discourse existential operator (or by another operator, in whose restrictive term they occur). This could give us, then, the maximal (specific) and the intermediate wide scopes discussed in Section 2. This line was, indeed, developed by Beghelli (1993, 1995), who argues that indefinites are unselectively bound by an existential operator, which is located, syntactically, at the C projection. But it should be trivial to observe now, as Heim (1982) did, that we certainly cannot give up QR to handle these cases with unselective binding. Nor, equally, can we replace QR, for this problem, with the absorption mechanism, which moves the determiner alone while leaving the N in situ.

Let us first check this with the same conditional context we have already processed several times. (I do this just because among the examples involving islands, these are the easiest to explain. The problem is much broader, as we will see.)

- (47) If we invite some philosopher, Max will be offended.
- (48) *Derivation without QR (unselective binding):*
 \exists [if we invite [some philosopher], Max will be offended]
- (49) $\exists x ((\text{philosopher}(x) \ \& \ \text{we invite } x) \rightarrow (\text{Max will be offended}))$
- (50) *Derivation with QR:*

- a. [Some philosopher]_i [if we invite c_i Max will be offended]
 b. $\exists x$ (philosopher(x) \wedge (we invite x \rightarrow Max will be offended))

We are trying to capture the wide scope (specific) interpretation, that there is some philosopher such that if we invite that philosopher Max will be offended, namely (50b). The LF we derive with no QR can be (48), where we introduce an existential operator (or some syntactic binder). Recall that in the DRT framework *some* in (48) has no interpretation, so the structure is interpreted as in (49). If (47) is construed this way, can it ever be used falsely? Not in our present world, where there are many non-philosophers, hence, it is necessarily true that if they were both philosophers and invited, Max will be offended. But the actual (47) is not a necessary truth. So, the upshot is that if we give up QR, we generate the sentence with a meaning it cannot possibly have, and what's worse, we fail to generate a meaning under which it certainly can be used. The QR derivation (50), by contrast, yields the correct interpretation.

As I mentioned, this is not a problem for Heim's (1982) analysis of unselective binding. Fully aware of this problem, Heim first applies QR. For example, *some philosopher*, in (47), first moves to the topmost IP position, as in (50a) (violating subjacency). In this position the indefinite variable is unselectively bound by the (discourse) existential operator. In this case, her analysis is precisely identical to that obtained by QR without unselective binding. (It should be recalled that existential wide scope was not the problem that motivated unselective binding.)

It may be in place to check whether unselective binding can be modified to handle this problem, nevertheless. In Reinhart (1987) I argued that unselective binding cannot, in any case, apply to individual variables, and the variable bound in donkey-type contexts must be a set variable. (This was needed, independently of the present problem, to handle the proportion problem.)²¹ Beghelli (1993) extends this analysis to the problem of

²¹ For example, under the standard unselective binding proposed by Heim, (i) is assigned the representation (ii), which the sentence cannot, in fact, have. (As has been widely discussed, under this construal the sentence is true, if there are, e.g. 9 men who each buys one car without worshipping it, and one man who buys 100 cars and worships them all, since for most man-car pairs, the implication is true. But (i) cannot be true in this situation.)

- (i) Almost every man who buys a car worships it.
 (ii) Almost every $\langle x, y \rangle$ ((man(x) & car(y) & x buys y) \rightarrow (x worships y))
 (iii) Almost every $\langle x, Y \rangle$ (man(x) & $Y = \{z \mid \text{car}(z) \ \& \ x \text{ buys } z\}$ & $|Y| = 1$) \rightarrow (x worships Y)

To avoid this, the representation must be that in (iii) (from Reinhart, 1987, p. 144). What gets unselectively bound here is a set variable. Under this construal the implication must be true for most pairs of a man and the (maximal) set of all the cars he buys. So (i), construed as (iii) is correctly false in the situation described above.

wide existential scope. He argues that the existential operator unselectively binds a set variable. (His major motivation is to enable the analysis to capture plural cardinal indefinites). However, this analysis faces precisely the same problem. Let us repeat (47) in (51a), using a plural cardinal NP, for variety. Beghelli's analysis will be (51b), where Y is a set variable, denoting the maximal set of philosophers we invite, with the cardinality of 2.

- (51)a. If we invite two philosophers, Max will be offended.
 b. $\exists Y((|Y| = 2 \ \& \ Y = \{x \mid \text{philosopher}(x) \ \& \ \text{we invite } x\}) \rightarrow (\text{Max will be offended}))$

Again, all that (51b) says is that there is some set, such that if it has two members who are philosophers that we invite, Max will be offended. There are many sets that meet this requirement (not only non-philosopher sets, but also the null set). So the sentence ends up a necessary truth.

We have to conclude, then, that unselective binding does not provide us with the magic formula that can eliminate the idea of an island free QR. We should keep in mind that the interpretation problem at issue is substantial. Though I focused attention on conditional structures, this is only for reasons of presentation. The same problem will show up whenever the existential NP occurs in the restrictive term of a universal quantifier, as in (52). (If these sentences are interpreted by unselective binding, leaving the N-set in situ, they end up a necessary truth, in every world whose entities are not only problems and philosophers.)

- (52)a. Every student who solved some problem got a prize
 b. Every joke about some philosopher got published.

More generally, the problem shows up in any downwards entailment context. For example, in the scope of negation, in (53).²²

- (53)a. Max did not consider the possibility that some politician is corrupt.
 b. QR: $\exists x (\text{politician}(x) \ \& \ \neg(\text{Max consider the possibility that } x \text{ is corrupt}))$
 c. *Unselective binding*: $\exists x \neg(\text{Max consider the possibility that } [x \text{ is corrupt} \ \& \ \text{politician}(x)])$

We are considering here the wide-scope (or 'specific') interpretation of *some politician* in (53a), namely, the construal (53b), which would be derived if QR can extract the existential out of an island. But under the

²² This point was brought to my attention by Danny Fox.

unselective binding procedure, it gets the construal (53c) where the N-restriction stays in situ, in the scope of negation. While (53a) clearly can have a reading corresponding to (53b), it can never be used to mean anything like (53c): One of the situations that will make (53a) false is if for all politicians, Max considered the possibility that they are corrupt. But, under the construal in (53c), it can still be easily true in that state of affairs. It is highly likely that there is some non politician entity about which Max did not consider the possibility that it is a politician (and corrupt). The problem can easily be extended to modals (e.g. take (53a) with *Max could have*, or *should have considered*, instead of *did not consider*).

Again, this problem surfaces equally in the other contexts of existential wide scope we examined, like *wh*-in-situ and sluicing:

- (54)a. Max would not even consider the possibility that some politician is corrupt, and you can easily imagine which.
 b. Which journalist did not consider the possibility that which politician is corrupt.

In these cases, the fact that the existential must have wide scope is syntactically determined (as we saw). If wide scope is interpreted by unselective binding, then they only have the construal along the lines of (53c). Donald Duck, then, should be a perfectly possible answer, as the value of *which* (*politician*).

I focused here only on cases which involve wide-scope out of islands, since these are the areas where the traditional QR faces problems. However, if we allow into the computational system the option of assigning wide scope via unselective binding, there is no way to restrict it to just the cases an existential occurs in an island (except, of course, by stipulation). If this is a free legitimate operation, then the interpretation problems we observed extends to the most basic cases. Specifically, the negation problem will show up everywhere, as below.

- (55)a. The students did not understand some argument.
 b. $(\exists x) \neg(\text{the students understand } x \ \& \ x \text{ is an argument})$
 (56)a. Which students did not understand which argument?
 b. Which $\langle x, y \rangle$ ($(x \text{ is a student}) \ \& \ \neg(x \text{ understand } y \ \& \ y \text{ is an argument})$)
 $\{P \mid \exists \langle x, y \rangle (\text{student}(x) \ \& \ P = \neg(x \text{ understand } y \ \& \ \text{argument}(y)) \ \& \ \text{true}(P))\}$

If we leave the N-set in situ and interpret it as in (b) of these examples, it is hard to imagine a context in which (55a) could be false in our actual

world, and anything could serve as a value of y in (56b). Any attempt to pull the restriction, somehow, outside of the scope of negation, would amount eventually to just an implicit application of QR. Though in these cases it is possible to apply QR to rescue also a correct representation for the sentences. The problem is how to block the interpretations derived here, if scoping by unselective binding exists.

4. THE SEMANTIC PROBLEM WITH ISLAND-FREE QR

We seem to be back where we started. So far, the only analysis which seems to capture correctly the wide scope of existentials is island-free QR. In all the examples discussed in Section 3, the semantic problem will be eliminated if we just keep QR as the way to derive existential wide-scope. It may appear that an option left is forgetting about the syntactic problems of the island-free QR, and the sluicing problem, which cannot be addressed within the QR framework, and going back to it, in order to save at least the elementary question of interpretation.

This last option, however, rests on the assumption which I followed so far, that the island-free QR captures correctly the semantics of existential wide scope, and the problems are only syntactic. There is good reason to doubt this assumption, which surfaces when we focus on plural (cardinal) existentials.

Plural existentials can be interpreted distributively or collectively. Let us focus on the distributive reading, illustrated in (58).

- (58)a. A guard is standing in front of two buildings
 b. There are two buildings such that in front of each there stands a guard.

The wide scope distributive reading of (58a) is paraphrased in (58b). In principle *two buildings* could also be interpreted with a narrow scope, or with wide-scope collective construal, but these two happen to be inconsistent with world knowledge, entailing one and the same guard standing in front of (a set of) two buildings. Hence, it is easy to focus here on the intended reading.

To derive this reading, the NP *two buildings* must first be raised by QR, as in (59).

- (59) [two buildings]_i [a guard is standing in front of e_i]
 (60) \exists two x (building (x) & $\exists y$ guard (y) & y stands in front of x)
 (61)a. [two buildings] λz (a guard is standing in front of z)

- b. $\exists X$ (two (X) & building (X) & X DAZ ($\exists y$ (guard(y) & y is standing in front of z)))

From there on, there are two basic (families) of approaches: Either the raised NP is interpreted as a standard generalized quantifier (over the domain of singular individuals), which is then, necessarily distributive. In that case, the interpretation will be already equivalent to that informally represented in (60), which is what we wanted to capture. The alternative is to assume that the basic (or only) interpretation of plural cardinals is as sets, or 'plural-individuals', and a distributivity operator makes the predicate apply to each singular member of this set. In this particular example, the predicate is not just the VP, but the complex λ predicate of (61a). I represent this schematically in (61b), where D stands for a distributivity operator. The effect of this operator is that for each x which is a member of the set X of two buildings, the λ predicate holds, namely there is a guard standing in front of it. There are many implementations of this line, and the details are not important for the present discussion. In any case, the interpretation along this line should be equivalent to that of the standard generalized quantifier interpretation (as in Barwise and Cooper (1981)).

In (59), QR is non-problematic, since there are no islands on the way. Our question is whether it can apply in the same way also outside of an island, as entailed by the island-free approach. Ruys (1992, 1995) observed that when existentials take scope outside of an island, they do not, in fact, allow the GQ (distributive) interpretation. Let us see this with one of his examples (from Ruys (1995)).

- (62) If three relatives of mine die, I will inherit a house.

(62) has the interpretation we have been calling all along the wide existential scope, namely, it can be construed as talking about three specific relatives of mine (rather than about any three relatives, as it would be under the narrow scope reading, which is also available for this sentence.) Nevertheless, it does not have the GQ reading we have been examining. Suppose QR applies, as in (59), to generate (63a). Applying the standard GQ interpretation, we get here (an equivalent of) (63b).

- (63)a. [three relatives of mine]_i [if e_i die, I will inherit a house]
 b. \exists three x (relative of mine (x) & (x dies \rightarrow I inherit a house))

Construed this way, the sentence will be true if there are three relatives for each of whom it holds that if s/he dies, I inherit a house. That is, I could inherit a house if only one of these relatives die. But (62) clearly

cannot be true in this case. The only wide-scope interpretation it has is that there is a set of three relatives, such that if each one of them dies, I inherit a house (namely, they all have to die). Under the standard GO construal of existentials, (63b) is the only interpretation we can derive for the syntactic representation (63a). Thus, applying free QR to an existential GQ both fails to capture the wide scope reading the sentence has, and generates a reading it does not have.²³

This may appear as no concern for approaches that assume, following the DRT tradition, that the existentials of the relevant type are never, anyway, interpreted as generalized quantifiers. In these approaches, the distributive operator is always independent of the scope of the existential. (See Szabolcsi (1995) for a survey.) But in fact, the same wrong interpretation arises also in these approaches. Suppose *three relatives of mine* denotes a set, or a plural individual. The predicate applying to it, if we let QR apply here, is the λ predicate in (64a). Applying the distributive operator to that predicate, as in (64b) we get precisely the same interpretation as in (63b), which the sentence does not have.

- (64)a. [three relatives of mine] λz (if z dies, I inherit a house)
 b. $\exists X$ (three (X) & relatives of mine (X) & $X D \lambda z$ (z dies \rightarrow I inherit a house))
 c. $\exists X$ (three (X) & relatives of mine (X) & ($X D \lambda z$ (z dies)) \rightarrow (I inherit a house))

Under this second approach it is possible to generate also the correct interpretation for the sentence: If we apply the distributive operator to the predicate *die*, rather than to the full λ predicate of (64a), we get the correct interpretation, as in (64c). (The statement that each member of the set dies is now inside the conditional.) The problem is, however, what prevents the wrong interpretation we are considering from being generated as well. As we saw in (61), the distributive operator must be able to apply also to predicates created by QR, to allow for the wide scope distributive readings of such sentences, so nothing rules it out in the case of (63). The problem with allowing island-free QR, then, is that this overgenerates – deriving non-existent readings, also if the existential is not a standard generalized quantifier. Several other instances of this problem are discussed in Winter (1997).

²³ Ruys concludes that the apparent wide-scope is not, in fact, a real wide scope, but rather, what he calls ‘non scope’. Based on this conclusion, he develops a mechanism for capturing scope and non-scope, using a system of superscripts. The mechanism needs to prevent indefinites from taking scope over other NPs, while still having this apparent wide scope. So a certain complexity of the machinery is entailed.

In several recent implementations of the non-GQ approach to existentials, it was argued that, under their distributive interpretation, indefinites can never, in fact, have wide scope over NPs they do not c-command, i.e. the distributive scope of existentials is only their overt scope (Ben-Shalom (1993), Beghelli and Stowell (1997), Szabolcsi (1997), Kamp and Reyle (1993), Ruys (1992)). Technically, this result can be obtained if the scope of the distributive operator is restricted to be only the VP, independently of what the scope of the existential NP is. If true, this will eliminate the overgeneration in (63). But it would equally eliminate the distributive wide scope we observed in the buildings-guard example in (58). It is hard to see how this intuition could be reconciled with the relative ease at which we get non overt distributive wide scope in such cases.²⁴

²⁴ The conclusion that indefinites distribute only over their overt domain is based on examining sentences like (i) (observed also in Verkuyl (1988)).

- (i) Three men lifted two tables.

Though I share the feeling that it is not easy to get the relevant reading in such examples, it is not obvious that this is any different than the case of non overt scope with strong quantifiers. The reaction of the other references cited above to (i) is very similar to the one some scholars had in the seventies to the idea that in sentences like (ii), the object can have wide scope over the subject.

- (ii) Some tourists visited every museum.

In Reinhart (1976), I argued that 'in spite of earlier reports in the literature' in sentence like (ii) the universal cannot have scope over the subject (a position I had to retract). Much more convincing examples were found over the years to show the existence of such reading, among them (iii), discussed by Hirschbühler (1982) in a different context.

- (iii) An American flag was hanging in front of every building.

Indeed, in the similar context of (58), it is much easier to get the wide scope of the object existential. At the present stage of the theory, it would be extremely difficult to decide whether there is indeed any difference in intuitions regarding wide scope between (i) and (ii), or we just have internalized the theoretical decision that wide scope of universal-NP objects is easily obtained. The fact remains that in empirical studies, non-linguist subjects have difficulties in retrieving wide scope readings of sentences like (ii). For example, in a cross-language study, Gil (1982) found that although non-overt scope exists in such cases, the preferred reading (statistically) is overwhelmingly the overt one. It appears that the state of the arts with covert GQ scope remains as already described in Ioup (1975): Its availability varies dramatically with all kinds of factors. As long as we do not reach clearer generalizations, beyond mere lists, there is no reason to take one of the contexts as more representative of the behavior of scope than the others. We may as well take (58) as the representative example, and leave open the question why it is so difficult to obtain the same reading in (i).

The opposite decision taken by Ruys and the studies cited (to ignore (58) and build the theory around (i)) amounts to just adding one more problem-specific rule to the many such rules we have already accumulated. Coached in the QR approach, we now will have the following list: (a) Existential GQs (or distributively interpreted existentials) do not move at all. (b) Strong (universal) GQs move only in their clause. (c) Non GQ existentials (or Collective) can move in an island free way. (d) Overt (*wh*) can move outside the clause, but

One thing we can safely conclude is that wide scope outside an island is not possible if a plural existential is construed as a (standard) generalized quantifier. So whatever this scope-option is, it is not what would be obtained by applying QR to such a GQ. The other approaches, viewing existentials as non-GQ, are often less restricted, so it is possible that new machinery can be introduced to handle the problem posed by sentences like (62).²⁵ However, the point remains that the semantics of existential wide-scope out of islands is not as entailed by an island-free QR, unaided by lists of stipulations. In Section 6.5 we will see other instances where it is not clear that natural language has the full range of options predicted by allowing QR to generate free wide scope of standard existential GQs.

5. AN INTERMEDIATE SUMMARY

Let me summarize the picture which emerges: We saw that existentials, unlike universally quantified NPs, allow arbitrary wide scope. This cannot be dismissed as a problem of vagueness. Nor can it be reduced to 'specificity' or 'referentiality' options of existential NPs.

Apart from this problem, however, there is no serious reason to abandon the earlier optimism of the QR view. We saw (in Section 1.5) that there are many instances where a rule like QR is needed, and in all these it behaves, essentially, as entailed by known constraints on syntactic-movement. In the specific area of relative quantifier scope, there may be further restrictions or contextual strategies that dictate scopal preferences and exclude options permitted by QR. Furthermore, it has been widely observed that, except for the case of existentials, non overt quantifier scope is a marked option: It is often very hard to obtain and it requires a strong discourse motivation (see footnote 24). In Reinhart (1995), I argue that the marked nature of QR can follow from a theory of economy. Roughly, optional syntactic operations are not allowed in the framework

obeys islands. Despite the rich machinery, this leaves out cases like (58), and many others I mentioned along the way, which we keep for the time being under lists of exceptions.

²⁵ I discussed here only the semantic approaches to the distributivity operator, as e.g. in Kamp and Reyle (1993). In the syntactic approach developed by Beghelli and Stowell (1997), this operator is generated as a syntactic node (a head of a special Distributive projection, which is generated below the Subject Agreement projection). It could perhaps be suggested that this head can further move, to allow the relevant distributivity in (58), and it is this movement which obeys subadjacency, though the movement of the existential does not. If the \bar{D} is generated inside the *if* clause in (62), it cannot move out to distribute over the whole λ predicate of (63). This line amounts to adding a fifth stipulation to the list at the end of footnote 24: e. covert movement of the D-operator does obey subadjacency.

of the minimalist program, unless this is the only way to obtain a given interface effect.

The serious problem, however, is the free wide scope of existentials. To capture correctly this apparent wide scope we need to assume a completely *ad-hoc* rule specific to existentials of the relevant type, which is free of any syntactic constraints. The no-movement alternatives we examined so far (in Section 3) fail dramatically to capture the wide scope interpretation. Apart from the theoretical cost of this *ad-hoc* rule, it faces empirical syntactic problems, e.g. in the area of *wh*-in situ (touched briefly in Section 2). On top of all that, as we last saw in Section 4, it is not obvious that this *ad-hoc* QR rule can always capture correctly the truth conditions of wide scope found in natural language. Obviously, what we would like to have is some way to capture the behavior of the relevant existentials without moving them, and still get their truth conditions right.

An alternative implementation of what QR captures has been developed in the DRT tradition. This is based on assuming restricted variables. In Kamp and Reyle (1993) it is postulated that all the NP-internal restrictions are entered when the discourse variable is introduced (i.e. at the top box). Szabolcsi (1995, 1997) proposes that these variables range over minimal witness sets of the *GQ* that the relevant NP denotes. This line resembles the mechanism of quantifier storage of Cooper (1983). We know already, from the previous round of quantifier storage, that this mechanism is, indeed, equivalent to QR, since it has the same effect as pulling the whole NP out of its original position, so these implementations face none of the problems discussed in Section 3. To evaluate the predictions this line makes in comparison to QR, we need to know how precisely this pulling out of the restriction is derived compositionally, which is not always spelled out. But a fully formal implementation of this storage procedure is provided in Abusch (1994). Due to the explicit execution, it is easy to observe that her system is precisely equivalent to QR, hence it faces the same problem we observed for QR in Section 4.²⁶

Nevertheless, all the approaches surveyed here, including also those in terms of unselective binding that we surveyed in Section 3, are aiming at

²⁶ Abusch follows DRT in assuming that indefinites are restricted variables. These variables are stored at each cycle, together with their whole NP-restrictions, until they reach the restrictive term of the operator that can bind them. This is precisely what QR does, and it yields the same readings of the three-relatives example (62) as QR. Thus, it faces the same difficulty as to whether the wrong reading (64b) can be excluded, without incorrectly excluding also (58). (Abusch's judgments of the facts of (62) and (63) are different than Ruys's and mine, so this is not, technically, a problem for her analysis. But if the judgments as presented here and in Winter (1997) are correct, it is not obvious how the system could be extended to account for them.)

precisely the same intuition, that it should be, somehow, possible to capture the interpretation of indefinites of the relevant type in situ. I believe this same intuition can be captured in the analysis I turn to propose, which expands the choice-function approach to existential wide-scope I suggested in Reinhart (1992).

In sum, what I assume is that QR can generate non-overt scope, subject to standard constraints on movements. All GQs can undergo QR, including the existentials under consideration. But these existentials share a property that enables them to get wide scope also without movement. For this reason, it is easy for them to obtain any non-overt scope, as opposed to the costly way open for the other GQs – to obtain it by movement.

6. A CHOICE-FUNCTION ANALYSIS

6.1. *Choice Functions and Existential Closure*

The interpretative problem is how to assign wide scope to existential NPs, which, otherwise, show properties of remaining in situ. Specifically, how can the N-restriction remain in situ, while still being interpreted as a restriction on a remote operator. Taking seriously the idea that the existential NP does not have to move means that it should be interpretable as an argument (rather than either a predicate or a generalized quantifier).

A simple way to do that, outlined in Reinhart (1992), is to allow existential quantification over choice functions. As a first approximation, let us assume the following description of choice functions:

A function f is a choice function ($CH(f)$) if it applies to any non-empty set and yields a member of that set.

Let me, first, illustrate the intuition behind this line, before addressing its formal properties in the next sections. This requires abstracting away, for the time being, from the question what happens when the N-set is empty, to which I turn in Section 6.5.

Suppose we want to represent the wide scope of *some book* in (65a), without pulling its restriction out. This can be done as in (65b).

- (65)a. Every lady read some book
 b. $\exists f (CH(f) \wedge \forall z (\text{lady}(z) \rightarrow z \text{ read } f(\text{book})))$
 c. $\exists x (\text{book}(x) \wedge \forall z (\text{lady}(z) \rightarrow z \text{ read } x))$

In (65b), a choice function applies to the set of books. The function variable can be bound by an existential operator arbitrarily far away. (65b) says that a function exists, such that for every z , if z is a lady, then z reads

the book selected by this function. As desired, $f(\textit{book})$ here is an argument (of *read*), which corresponds to the fact that its NP stayed, syntactically, in an argument position, and it denotes the value of the function f , i.e. a given book.

Note that the choice function used here is simpler than the more familiar Skolem functions, employed to capture narrow scope of existentials, where the choice of value for them varies with the choice of value for some bound variable. Though choice functions have been studied by logicians (since Hilbert and Bernays (1939)), not much attention has been given before, in the linguistic literature, to this option of capturing existential wide scope. This is, possibly, since capturing wide scope in cases like (65) has never seemed a particularly interesting problem.²⁷ Consequently, this use of choice functions has not been fully researched. Still, in a model where the N set is not empty, (65b) is equivalent to the standard existential wide scope in (65c), which is the interpretation we want to capture.

Let us check how the same procedure applies when the N -restriction occurs in the antecedent clause of an implication, since these are the contexts which posed problems to absorption or unselective binding.

(47) If we invite some philosopher, Max will be offended.

(48) *Derivation with unselective binding:*

a. \exists_i [if we invite [some philosopher] _{i} ; Max will be offended]

²⁷ In Engdahl's (1980) analysis of *wh* question, she introduced an idea which appears similar to that of choice functions: She defined a function W which applies to a set and yields a subset of this set, and allowed the function variable to be existentially closed from a distance. However, what Engdahl intended to capture with this function was not the standard wide scope problem, (which she too considered non problematic), but rather anaphora problems such as in (i) (Engdahl's Swedish (47)–(48), p. 140) where, under one reading, the antecedent for the pronoun appears not to have scope over it (as she states the problem, on p. 141).

(i)a. Which of his books does every author usually recommend?

b. Which of his poems did Maja want an author to read?

In Engdahl (1986), she observed, correctly, a flaw in the analysis. She concluded that the procedure she proposed in (1980) cannot, in fact, handle the problem they were designed to capture, and abandoned this line. I believe this was the correct move. The case of (i), and, more generally, 'functional readings' of questions are typically the inverse problem of what we are considering here: The existential is dependent upon some other quantifier, although it appears to take wider scope than that quantifier. The simple choice-functions I examine here are applicable strictly for the cases of independent (genuine) wide scope. For the 'dependent' wide scope, some equivalent of the more complex Skolem function must be used (i.e. the choice of member must be relative to a choice of value of some other variable). Various implementations (apart from Engdahl herself, in 1986) are Chierchia (1993), and Kratzer (1995). (In Reinhart (1992), I made a similar mistake to that of Engdahl's (1980), in assuming that simple choice-functions could be extended to capture some subset of the anaphora problems of the Engdahl-type.)

- b. $\exists x ((\text{philosopher}(x) \wedge \text{we invite } x) \rightarrow (\text{Max will be offended}))$
- (50) *Derivation with QR:*
- a. $[\text{Some philosopher}]_i [\text{if we invite } e_i \text{ Max will be offended}]$
- b. $\exists x (\text{philosopher}(x) \wedge (\text{we invite } x \rightarrow \text{Max will be offended}))$
- (66) *Choice-function interpretation:*
- $\exists f (\text{CH}(f) \wedge (\text{we invite } f(\text{philosopher}) \rightarrow \text{Max will be offended}))$

The problem we observed with (47), repeated, was that if we leave the N restriction in situ, and bind it unselectively, as in (48), the sentence ends up a necessary truth in any world which contains non-philosophers. (Assume, e.g. that the philosophers-set is not empty at that world. Nevertheless, there is always some non-philosopher entity, of whom the implication is true). This problem is eliminated when we apply the choice function procedure, as in (66). Although the N-restriction stays in situ just the same, the NP in-situ can now denote only a philosopher. ((66) says that a function exists, such that if we invite the philosopher it selects, Max will be offended.) Assuming, again, that the philosopher-set is not empty, (66) ends up equivalent to the standard representation of wide scope in (50b), repeated, which is obtained if we apply an island-free QR. A different question, which we have been postponing (till Section 6.5), is what happens when the philosopher-set is empty.

Negation contexts are also no longer a problem. The wide existential scope in (53a), repeated in (67a), is represented in (67b). What occurs in the scope of negation here is the politician value of the function. ((62) asserts that a function exists, such that it is not the case that Max considered the possibility that the politician it selects is corrupt.) So it is no longer the case that anything could be a value of the variable.

- (67)a. Max did not consider the possibility that some politician is corrupt.
- b. $\exists f (\text{CH}(f) \wedge \neg(\text{Max consider the possibility that } f(\text{politician}) \text{ is corrupt}))$

Next, let us look at the cases of ‘intermediate’ wide scope discussed in Section 1.3. As we saw, in (21), repeated in (68a), the choice of a problem may vary with the choice of a linguist, in which case *some problem* is not specific. Still it can take scope over *every analysis*.

- (68)a. Most linguists have looked at every analysis that solves some problem.
- b. $[\text{Most linguists}]_1 [[\text{every analysis that solves some problem}]_2 [e_1 \text{ looked at } e_2]]$

- (68)c. For most linguists x , $\exists f$ ($\text{CH}(f) \wedge \forall y$ ((analysis(y) \wedge y solves f (problem)) \rightarrow x looked at y))

Assuming that existentials can be interpreted without movement, via a choice function, this reading of (68a) is not a problem. Existential closure of the function variable (its binding by an existential operator) is a purely interpretative procedure applying arbitrarily far away, so there is no reason why not to introduce this existential also in the scope of another operator. If it is introduced (informally) as in (68c), we obtain the interpretation under consideration. (In the QR framework, this representation will be derived by first applying QR to the *every* QNPs, as in (68b). The binding existential can be introduced anywhere in that derivation. But these are independent details, on which nothing hinges for the present discussion.)

Let us turn to the problem of *wh*-existentials. Crucially, in all standard semantic approaches to questions (e.g. in the approach of Karttunen which I assumed here), *wh*-NPs are translated as existential quantifiers. Hence, we can apply to them straightforwardly the same mechanism of quantifying over choice functions. In (69a), *which lady* moved overtly, but we are interested in the interpretation of the *wh*-in situ *which book*. Let us abstract away from the moved NP and maintain the standard (existential) interpretation for it. For the *wh*-in-situ *which book* we apply a choice function, yielding $f(\text{book})$. The function variable will then be bound by the relevant question operator illustrated informally in (69b), yielding the question denotation (69c). (The question denotes here the set of true propositions P , each stating for some lady x and for some function f that x read the book selected by f .)

- (69)a. Which lady e read which book?
 b. For which $\langle x, f \rangle$, ($\text{lady}(x)$) and (x read $f(\text{book})$)
 c. $\{P \mid \exists \langle x, f \rangle (\text{CH}(f) \wedge \text{lady}(x) \wedge P = \wedge(x \text{ read } f(\text{book})) \wedge \text{true}(P))\}$
 d. $\{P \mid \exists \langle g, f \rangle (\text{CH}(g) \wedge \text{CH}(f) \wedge P = \wedge(g(\text{lady}) \text{ read } f(\text{book})) \wedge \text{true}(P))\}$

As for the moved *which lady*, technically, it is no longer in an argument position, so it cannot be directly interpreted as an argument of the form $f(\text{lady})$. If we want to nevertheless maintain uniformity of interpretation for all *wh*-expressions, some covert syntactic operation could apply to (69a), to turn it back into an argument (either by introducing a λ operator or by reconstruction), in which case an interpretation like (69d) could be assigned. Nothing here hinges on whether we decide to do this or not.

Turning to the conditionals problem repeated in (70), we apply the same procedure, where the choice function selects a value from the philosophers set. Although the restriction occurs in an *if*-clause the values permitted in the answer can only be from the philosophers set, as we saw already in the discussion of (66), with the existential *some philosopher*.

- (70)a. Who will be offended if we invite which philosopher?
 b. For which $\langle x, f \rangle$, if we invite $f(\text{philosopher})$, x will be offended.
 c. $\{P \mid \exists \langle x, f \rangle (\text{CH}(f) \wedge P = \neg(\text{we invite } f(\text{philosopher}) \rightarrow x \text{ will be offended}) \wedge \text{true}(P))\}$

The sluicing cases also follow straightforwardly. As we saw, following Chung et al., the antecedent clause of, e.g. (71a) gets copied into the sluice clause, as is, yielding (71b).

- (71)a. Max and *some lady* disappeared, but I can't remember which
 []
 b. Max and some lady disappeared, but I can't remember which
 [Max and some lady disappeared]
 (72)a. But I can't remember which [Max and $f(\text{lady})$ disappeared]
 b. But I can't remember which f (Max and $f(\text{lady})$ disappeared)
 c. But I can't remember $\{P \mid \exists f (\text{CH}(f) \wedge P = \neg(\text{Max and } f(\text{lady}) \text{ disappeared}) \& \text{true}(P))\}$

Let us now focus on the resulting second conjunct in (71b). The embedded question there looks like gibberish, and the analysis makes sense only if the correct question interpretation may be derived for it. Recall that the determiner *some* plays no role semantically so we may treat the indefinite *some lady* in the same way we have been doing above, by introducing a choice function variable to select from the set of ladies, as in (72a). This function-variable must be now existentially closed. Since it occurs in a question-context, it gets bound by the existential activated by *which*. This binding is illustrated informally in (72b), and it is translated into the standard question representation, in (72c). (72c) is, indeed, the question denoted by the second conjunct of (71a), namely the interpretation we wanted to derive for the sluiced part. The correlate existential *can*, under such construal, occur in an antecedent of an implication, or in the scope of negation, since it will be correctly interpreted, as in the previous cases we examined in (68) and (70).

It is easy to observe that the same analysis will apply to all the cases we considered so far, with the correct results, so it seems that assigning wide scope to existentials without moving their restriction is possible.

6.2. *Deriving the Choice-Function Interpretation*

Let me, first, be more specific on how the choice-function interpretation is compositionally derived.

One of the basic insights of DRT is that indefinite NPs of the relevant type lack a quantificational determiner, i.e. what may appear syntactically to be an indefinite determiner (*a, some, three*) is not a determiner in the semantic sense, which could turn the NP into a standard generalized quantifier. This means that an indefinite NP of this type just denotes a predicate (of type $\langle e, t \rangle$) and the question is how we proceed from that starting point.

It will be useful to have, at this point, some picture regarding the internal structure of NPs. In the syntactic framework, it is assumed that the relevant projection here is DP (Determiner phrase), which contains an NP. Without entering the massive syntactic literature on the analysis of DPs, let us assume that what indefinite DPs lack in this case is SPEC of DP, so their structure is as represented schematically in (73), a view developed in Danon (1996).²⁸

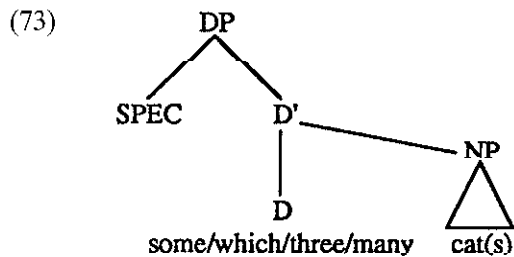

Let us assume, further, that what determines the quantificational force of a DP is its SPEC, which hosts (semantic) determiners of the GQ type. The D-head of the projection only hosts features (relevant both for syntactic agreement and for interpretation) like number, $\pm wh$, or gender (in some languages). The determiner words here are all (X^0) so they can serve as the D-heads. However, they can also head a projection of their own and be inserted at the SPEC position.

In the DRT framework (e.g. Kamp and Reyle (1993)), it is assumed that the indefinites of our relevant type can never be construed also as

²⁸ The aspects of Danon's analysis which are crucial to the present problem are consistent with many other analyses (cited there). Danon offers evidence from Hebrew, where there are many syntactic tests to distinguish the D and the SPEC position of determiners. The D head in (73) is not necessarily generated in that position – it may originate inside the NP and then move to D. (Danon argues that, at least in Hebrew, this must be the case.)

GQ, which, in our syntactic terms means they only have the structure in (73). This, however, is not really motivated syntactically. In principle, heads can project to an XP, and as XPs, they can occur in the SPEC position. This is visible with modified numerals, such as *more than three*, *exactly three*, which are clearly XPs, but there is no reason why, say, *three* alone cannot also head an XP (unmodified). If it does, it is inserted in SPEC DP. If this is the case, SPEC is interpreted as a standard semantic (existential) determiner, and the DP denotes a GQ.²⁹ I will assume, then, that the indefinites of the relevant type also allow the standard GQ interpretation, though nothing in my semantic analysis actually hinges on this assumption, so it can be excluded, by stipulation.³⁰

In any case, we are now concerned with how the structure in (73) is interpreted. As observed, the D' projection (which includes the NP) denotes only a predicate (based on the N-set), with at most a cardinality marker. Let us start with the case of singular indefinites. The neutral assumption is that the predicate is of type $\langle e, t \rangle$. To enable function application, (say, with the VP denotation) some covert function must be introduced, to do the job of the empty SPEC, which usually hosts a function. In principle, this could be either of the type $\langle \langle e, t \rangle, \langle \langle e, t \rangle, t \rangle \rangle$, which would turn the DP into a generalized quantifier, or of the type $\langle \langle e, t \rangle, e \rangle$, which turns it into an individual. A choice-function analysis along the first line is developed in Winter (1997), but here I will pursue the second. A choice-function variable is then introduced as in (74).³¹

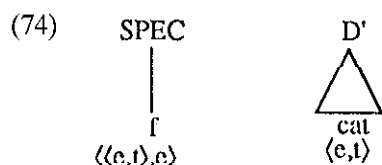

At this stage, we have a function variable, which must still be existentially closed. The intuition expressed in DRT, that indefinites of this type correspond in some sense to free variables can be maintained, thus, with-

²⁹ Danon (1996) shows that in Hebrew, where the two positions are easily distinguishable, unmodified *three* can occur in both positions.

³⁰ With some D's, like *which*, *a*, *some*, there is stronger motivation to assume they never occur in SPEC DP, since they can never be modified. Syntactically, this may suggest that they are unable to project an XP. The question whether we want them nevertheless to allow a GQ interpretation becomes then, a purely semantic question. If maintaining this option is motivated, a covert Existential (GQ) determiner may be assumed to be optional in SPEC DP.

³¹ For the time being, the fact that the function must be of the choice type (rather than any arbitrary function) must be stipulated.

out assuming the individual variables of Heim (1982). For the binding of the function variable, we may assume the procedure of existential closure discussed in Heim (1982). However, I assume, crucially, that such closure can apply only to function variables, and in no case do we allow unselective binding of individual variables. The default assumption is that closure can apply freely anywhere. If it needs to be further restricted, this would require some special restriction posed by the computational system, since it could not follow from logic. (Such restrictions were proposed by Heim for unselective binding.) But this does not seem necessary, since, as we saw in Section 1.3, the so called 'intermediate' wide-scope readings exist. These are derived if existential closure applies in the scope of another operator.

In the case of *wh*-in situ, such as *which woman*, under the semantics we assumed for them all along, they are viewed just as standard existentials, hence at the local NP-level they can be analyzed just as in (73). However, they differ from the other existentials in that their binding existential operator must be inserted in a predetermined position in the scope of the question-formation operator (which forms the set of propositions denoted by the question). In English, the position where closure applies is marked by the *wh*-constituent that moved overtly.

Summarizing, I assume that the computational system allows for indefinites two interpretative procedures. They can be either construed as standard existential generalized-quantifiers (over singular individuals), or with the choice-function interpretation. On the first, they behave like any other GQ, and their scope is restricted by syntax (i.e. it is either the overt scope, or that permitted by an island-sensitive QR). On the second, they can have any scope, depending on where we apply existential closure. (The assumption that the standard GQ construal is available as well can be dropped, without affecting the analysis of the second procedure.)

6.3. *The Collective-Distributive Distinction*

When we turn now to the plural indefinites, along the question of scope there is the question of the distinction between the collective and the distributive readings of existentials. The standard GQ construal always yields the distributive interpretation. Some procedure must be assumed, in all approaches, for deriving also the collective interpretation. Since we now have at our disposal an additional construal of indefinites, based on (74), we would not, ideally, like to assume that on top of the choice-function mechanism for scope we also have a separate machinery for

collectivity. I will argue that, indeed, the same choice-function procedure is also what generates the collective interpretation of plural indefinites.

That the two are related can be witnessed by examining again the problem raised by Ruys (1992), in (62), repeated.

- (62) If three relatives of mine die, I will inherit a house.
 (63)a. [three relatives of mine]_i [if e_i die, I will inherit a house]
 b. \exists three x (relative of mine (x) & (x dies \rightarrow I inherit a house))

We saw that under the wide scope of the existential, it cannot be construed as a standard GQ. If we apply QR to a GQ, we get a reading equivalent to (63b), a reading the sentence does not have. The only interpretation available is where the existential is taken as a collective set of three relatives, all of whom must die for the antecedent of the implication to be true.

To proceed we need first some analysis of plurals and collectivity. It is widely assumed that the cardinal in indefinites construed collectively (i.e. the D-head in (73)) is interpreted as some sort of a modifier, as in (75). (For example, in the modification view of Kamp and Reyle (1993), or in Higginbotham (1985), where a modification structure is described as enabling two variables to be 'discharged' by the same operator.)

- (75)a. Three women chatted.
 b. $\exists x$ (women(x) \wedge three (x) \wedge chatted (x))

But what is x in (75)? It could not be a standard individual variable, since we are not talking here about an individual with the property of being three. So it must denote a set, which appears to distinguish it from the case of singular indefinites.

A desire common to many approaches is to keep type uniformity in the analysis of singular and plural indefinites (though this is not a conceptual necessity). Two (families of) ways are available for that: either to reduce plural-sets to individuals, as in the tradition of Link (1983), or to lift singulars to sets, as proposed in Scha (1981). I will follow here the second line, since it enables one of the solutions to the empty-set problem that I discuss in Section 6.5. But other implementations are certainly conceivable.

On this view, the predicate must be lifted to type $\langle\langle e, t \rangle, t\rangle$, so it can apply to the set argument. This can be represented as in (76), where the Scha-star on the verb indicates that it denotes this higher type. (I will ignore this star in the subsequent discussion.)

- (76) $\exists X$ (women (X) \wedge $|X| = 3 \wedge$ *chatted (X))

- (77)a. Some/a/which woman chatted
- b. (...) $\exists X (\text{women}(X) \wedge |X| = 1 \wedge \text{*chatted}(X))$

Under the uniformity approach, singular indefinites are interpreted the same way, with the cardinality being 1, as in (77).³² Thus, singular indefinites (when not construed as a GQ) denote a singleton set.

Since the predication now is of the higher type, the next question is how it can distribute over individuals in the argument set when it is a plural set and this is a relevant interpretation. For the present discussion, any of the available approaches to distributivity can be assumed.³³

Returning now to the choice-function procedure, under this implementation, the value of a choice-function applying to the set in D', must always be a set, rather than an individual as assumed before (in (74)). That is, the function variable applies to a set of sets, and selects a set, as represented in (78a). To allow its use also under different implementations, let us assume the schematic description of the choice-function type in (78b), where T stands for a type, and its value may be either $\langle e \rangle$, or $\langle c, t \rangle$.

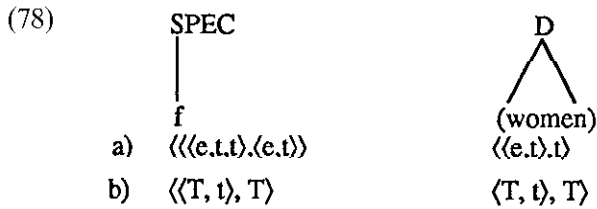

So, the representation of the NPs in (76)–(77) under the choice-function construal is given in (79b)–(80b). For convenience, I will continue to use the informal notation in (c), but it should be read as (b).

- (79)a. three women
- b. $f(\{X \mid \text{women}(X) \wedge |X| = 3\})$
- c. $f(\text{three women})$
- (80)a. Some/a/which woman chatted
- b. $f(\{X \mid \text{women}(X) \wedge |X| = 1\})$

³² Of course, under this construal the sentences are consistent with there being more than one, or than three women who chatted.

³³ Scha assumes that predicates of natural language are always of the $\langle\langle e, t \rangle, t\rangle$ type, and whether distribution is entailed is determined lexically by the type of the verb. However, a distributive operator can be defined for predicates of this type, as in (i), along the lines discussed in van der Does (1992).

(i) $D\langle\langle e, t \rangle, t\rangle\langle\langle e, t \rangle, t\rangle \stackrel{\text{def}}{=} \lambda P_{\langle\langle e, t \rangle, t\rangle} \cdot \lambda X_{\langle e, t \rangle} \cdot X \neq \emptyset \wedge \forall y \in X(P(\{y\}))$

(80)c. $f(\text{woman})$

With this assumed, we can turn to Ruys's problem in (62), repeated again in (81a), which posed a problem to the QR view. The function variable is introduced to apply to *three relatives* in situ. Its value now is a set of three relatives. Since we are interested in the wide scope construal, the function variable is existentially closed outside the conditional. The result is abbreviated in (81b), which should be read as (81c).

- (81)a. If three relatives of mine die, I will inherit a house.
 b. $\exists f (\text{CH } (f) \wedge (f(\text{three relatives of mine die} \rightarrow \text{I inherit a house})))$
 c. $\exists f (\text{CH } (f) \wedge ((f (\{Y \mid \text{relative of mine } (Y) \ \& \ \text{three } (Y)\}) \text{ die}) \rightarrow (\text{I inherit a house})))$

So, (81) now reads that there is a function f , such that if the set of three relatives it selects dies, I inherit a house. This death of a set is interpreted, under any distributivity mechanism, to mean that each member of this set dies.

In its treatment of collectivity, this analysis is just one of the possible variants of the standard view, which we observed in Section 4. However, as we saw in the discussion of (64), repeated, a problem in capturing the wide-scope collective reading with island-free QR was that it is not obvious how to prevent a distributivity operator from applying to the whole λ predicate obtained by QR, as in (64b), which yields the wrong distributive reading, just as (63) above.

- (64)a. $[\text{three relatives of mine}] \lambda z (\text{if } z \text{ dies, I inherit a house})$
 b. $\exists X (\text{three } (X) \ \& \ \text{relatives of mine } (X) \ \& \ X \ D \lambda z (z \text{ dies} \rightarrow \text{I inherit a house}))$

But this is precisely the problem eliminated by the choice-function approach. The indefinite is interpreted in situ (and it cannot, even optionally, be moved out of an island, since QR is island-sensitive.) Thus, in (81) there is no new predicate formed at the covert structure. The only predicate which takes a set argument is *die*, hence it is only this predicate that can distribute. So we derive only the interpretation the sentence indeed has: that there is a set of relatives, such that if each one of them dies, I inherit a house.

Under this analysis, then, the choice-function procedure is what generates the collective interpretation of plural existentials. It applies uniformly to generate the relevant set locally (in-situ). The question of scope is a by-product. Since the function variable can be existentially

closed anywhere, the scope of a collective existential NP is determined by where we choose to apply it.

Recall that the system still allows existential NPs to be construed as (distributive) GQ. In a previous draft, I assumed, following Scha (1981), that this may be all we need: Genuine distributivity is only obtained via the GQ procedure. As for the distributivity effects of the predicate (like *die*, in (81)), Scha argued that they may follow from the lexical semantics of the predicate, with no need to assume a special distributivity operator. However, Winter (1997) and Heim (p.c.) point out that this cannot be maintained, in view of more complex examples.³⁴ I therefore assume now that such an operator is needed. If this is the case, it becomes less obvious why we should allow also the GQ interpretation of the relevant existentials. Currently, this creates a redundancy, allowing two ways to derive what appears to be the same distributive reading. I leave open here the question whether the readings are indeed always identical, i.e. whether a GQ interpretation must still be available.

The crucial point I would like to maintain, though, is that there is no need to assume both a mechanism for deriving free wide scope of existentials and a separate mechanism for collective interpretations. Rather, these are instances of one and the same choice-function procedure.

6.4. Which Indefinites Are Interpretable by Choice-Functions

So far I have left open the question which indefinite NPs allow free wide-scope, and, correspondingly, a choice-function interpretation. As noted in Section 1, they must be weak, or existential (under Keenan's (1987) definition of the term), but it is not the case that all existentials allow free wide-scope. Beghelli (1993) and Szabolcsi (1995, 1997) argue that the relevant group includes only indefinites with unmodified (bare) numerals, of the kind I used in the examples throughout (*a, some, three, which, many*, etc.). This is the group which for Kamp and Reyle (1993) has only the set (or plural individual) interpretation. The other group, of existen-

³⁴ In examples like (i), from Winter, the preferred reading (under the wide scope construal) is as given in (ii).

- (i) If three workers have a baby soon, we will have to face some hard organizational problems.
- (ii) There is a set of three workers such that if each of them has a (different) child, we face organizational problems.

The distributivity of a predicate like *have a child* cannot be reduced to some lexical property. So we must assume some distributive operator applying to this predicate, which makes it hold for each member of the set of three workers (selected in situ by the choice function).

tials with modified numerals, includes all plural numerals which occur with any kind of a modifier: *less than three*, *more than three*, *exactly three*, *at least three*, *three or more*, *between three and five*, etc. Kamp and Reyle (K&R) argue that NPs of this type are interpreted only as generalized quantifiers.

If this grouping of existentials is correct, it should mean, under the present analysis, that the second group does not allow a choice-function interpretation. Consequently, their maximal scope cannot be wider than that allowed by an island-restricted QR.³⁵ Next, since choice-functions are what generate the collective readings, they should not allow a (genuine) collective interpretation. Both consequences are argued to be true in the studies cited, but let us examine here the second, which may appear more problematic, as presented there.

This requires more attention to collective predicates. Some such predicates, like *meet*, *surround*, or even *lift a piano* (under imperfective uses), appear easily also with a GQ (e.g. *Most students met*). But there is another group of collective predicates which does not, like *be a good team/couple*, or the collective *weigh two pounds*. Dowty (1986) suggests that in the predicates of the first group, there are sub-entailments regarding the role of each member of the set in the collective activity (so, loosely speaking, they remain distributive), but in the second, there are no such subentailments. Possibly, another characteristic of the difference is that if a predicate of the first type is true for some set, it is not excluded that it is true of some subset of this set. (If 100 people surround the yard, it is not excluded that 70 of them also surround the same yard.) But in predicates of the second type, this is excluded: If 3 potatoes weigh two pounds together, then it is false that two of them do, and a subset of a good team is not the same good team. Yoad Winter (p.c) observed that it is this second predicate group that should be checked to see whether an NP has a genuine (i.e. set) collective interpretation.³⁶ Indeed, bare numerals can occur with such predicates, as in (82), but strong GQ cannot, as in (83). The modified numerals in (84) pattern with the GQ, and it is much harder to assign any meaning to these sentences.

(82)a. Three/many potatoes weigh two pounds together.

³⁵ As I mentioned, in the studies cited it is assumed that their scope is, in fact, narrower than allowed by QR, a point we need not enter here.

³⁶ Deriving the collective interpretation of predicates of the first type, with a GQ subject is a long standing problem. Szabolcsi (1995) suggests (without actually distinguishing these two types) that in such cases, it is the predicate that denotes a collective set, though this still needs some spelling out.

- b. Ten/which workers in our office are a good team.
- (83)a. *?Most potatoes weigh ten pounds together.
 b. *?All workers in our office are a good team.
- (84)a. *?Less than five potatoes weigh two pounds together.
 *?At least three potatoes weigh two pounds together.
 b. *?More than ten workers in our office are a good team.
 *?Exactly ten workers in our office are a good team.

The question, in our terms, then, is why it is impossible to interpret modified numerals in the choice-function procedure. The puzzle posed by these numerals is that they do not form any known semantic set. They include both monotone decreasing (*less than three*), non-monotone (*exactly three*) and increasing quantifiers (*more than three*). Most puzzling is what semantic property could possibly distinguish between *three* and *at least three*.

Kamp and Reyle (1993) argue that bare numerals are precisely those that ‘introduce a discourse referent’. The modified numerals lack this discourse property. They offer, as a diagnostics of this property, an examination of anaphora behavior of the two types: A question in discourse anaphora is whether a pronoun in sentences like (85) refers back to the N set, or to the intersection set of N and the predicate.

- (85)a. Five students left shortly after the exam started. They could not understand the questions.
- b. More than four students left shortly after the exam started. They could not understand the questions.

Suppose 10 students actually left in our model. Could the pronoun nevertheless refer to just five students in (85a)? K&R’s judgment (shared by Szabolcsi (1997)) is that it can. But in (85b), the pronoun cannot refer to just any number greater than four. So, if only 5 students of those who left did not understand the questions, (85b) is false, but (85a) can still be true.

The judgments here are subtle,³⁷ but they are clearer on the second K&R test, with intra-sentential anaphora.

³⁷ Note that this goes against the judgments of Evans (1980), which I also defended in Reinhart (1986), where I argued that the antecedents for discourse anaphora must be defined on the intersection set. There, (ii) was judged as not equivalent to (i), since (ii) is consistent with there being cats that Lucie has and that Max does not take care of, while (i) is not. (But no special attention was given to the difference between *five* and *at least five*.)

- (i) Lucie has 5 cats and Max takes care of them.
 (ii) There are 5 cats that Lucie has and Max takes care of.

It is, in principle, possible to maintain the intersection view as a special property of discourse anaphora, without giving up the distinction under consideration.

(86)a. Three porters_i broke a table they_i lifted.

(86)b. At least three porters_i broke a table they_i lifted.

(86a) has both the collective and the distributive reading of the predicate. (86b) has only the distributive one, namely each of the three porters broke a table he lifted. Now, the pronoun under the collective reading of (86a) must be able to refer to the N-set alone.³⁸

Suppose, as is very likely, that the NPs interpretable by choice functions (or, in K&R's terms, as sets) have also some common discourse functions. Nevertheless, introducing the 'discourse referent' property is not, in itself, an answer to our problem, since this is not an inherent (logical) property of determiners or NPs, and the puzzle still remains why just the set of bare numeral indefinites should have this discourse function.

Possibly, a pragmatic answer could be sought, in terms of procedures of assessment. I believe this is the intuition behind Szabolcsi's (1995, 1997) attempt to define this set of indefinites in terms of their witness sets. She assumes that existentials of this type involve existential quantification over minimal witness sets. On this view, we could say that the basic interpretation of all existential NPs alike is that of a generalized quantifier. However, a typical property of indefinites of the relevant set is that they allow assessment by checking just one minimal witness set of the GQ.³⁹ Hence these indefinites are allowed to be interpreted also by existentially quantifying over such a witness set. (Translating this to the present framework, the choice function selects from the set of minimal witness sets.) As appealing as this line seems,⁴⁰ the problem, currently, is that it does not slice the set we want. Though it can be developed to exclude all non monotone-increasing existentials, it cannot exclude the other modified numerals. Specifically, it is not obvious why *more than three ladies smiled* cannot be assessed with a minimal witness set of four ladies, or, why *at least three* cannot be assessed by checking a minimal set of three. Nor is it obvious why it should not apply, just the same, in the case of strong increasing quantifiers.

In the absence of semantic or pragmatic properties that could distinguish the relevant groups, we may pay closer attention to their syntactic proper-

³⁸ Though the judgements are very clear, it is not fully clear what this is a test for. Possibly this is just a clearer way to show that NPs of the first type take a collective reading much more easily than the second. This result, however, is sufficient for the distinction I make below.

³⁹ A witness set, as defined by Barwise and Cooper (1981), is any set in the denotation of the GQ which is also a subset of its live-on set.

⁴⁰ Its appeal is in that it allows a unified treatment of all existentials as GQ's and enables the choice-function procedure as a special operation on their witness sets.

ties. Recall that in Section 6.2, I assumed following Danon (1996) that the relevant bare numerals have the structure (73), repeated.

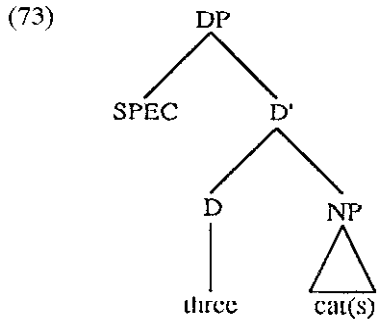

We noted that an element can occur in the D position in this structure only if it is of the X^0 syntactic type, i.e. it can serve as a head. A head cannot be modified by anything, hence modified numerals cannot occur in that position. On the other hand, the same head *three* can project its own XP, as is the case with modified numerals. As an XP, it can occur only in the SPEC position of (73). What modified numerals have in common, then, under Danon’s analysis, is that they have the structure in (87). (The D head in this structure hosts only syntactic features.)⁴¹

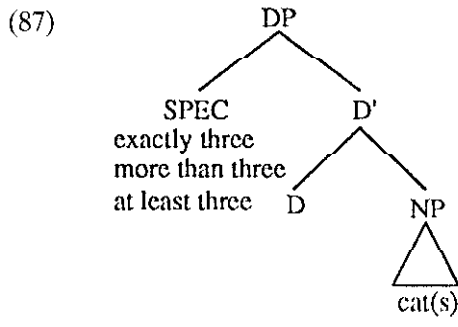

We assumed, further, that it is the SPEC position that always corresponds to a GQ semantic determiner. It follows then that indefinite NPs with this structure must be interpreted as GQs. On the other hand, we assumed that it is only when the SPEC position is empty, as in (73), that a choice function variable is introduced in this position, to enable function appli-

⁴¹ There is some room for variation here. Danon argues that some modifiers may occur as modifiers of the whole DP, or NP, or as adjectives, in which case, the numeral may still be the head of the DP. The Hebrew equivalent of *certain* (in *a certain student*) occurs as an NP modifier (*student mesuyam*).

cation. It follows, then, that precisely the set of bare numerals is interpretable by choice functions.

What this means, then, is that the interface of discourse and syntax, which was insightfully observed in the DRT framework, goes in this case, in the other direction than assumed there. It is not that discourse properties are coded in the syntax (or the formal semantics), but rather, independent properties of the human computational system (syntax) enable certain discourse uses. The choice-function procedure, whose semantics we are about to explore more closely, generates options that discourse strategies can happily use. Since the choice function variable can be existentially closed at any point, one of the options is to do that at the (widest) discourse level, in which case the indefinite can be used for forming a discourse entity.

6.5. *Some Choice-Function Semantics*

I have not been yet fully explicit on the formal characterization of the quantification I assume over choice function variables. There is no reason to expect that adapting this approach will require any less semantic work on its precise implications, than in the case of unselective binding, dynamic, or any of the other approaches to quantification. But let me point out here some basic questions that need to be addressed.

6.5.1. *The Empty-Set*

Our point of departure was attempting to capture the wide scope of existentials. So far I assumed that (at least in the singular case), its truth conditions are the same as would be obtained if we apply an island-free QR to standard (GQ) existentials. Before we can even check whether this is so or not, we must decide what happens when the D' set that a choice function applies to is empty, as in (88a) (assuming that there have been no American kings). Under the classical analysis in (88b) the sentence is false, but if we say nothing further the choice function in (88b) could just select any arbitrary value, so the sentence would come up true, in case someone visited Utrecht.

- (88)a. An American king visited Utrecht.
- b. $\exists x$ (American King (x) & x visited Utrecht)
- c. $\exists f$ (f(American king) visited Utrecht)

One line that may suggest itself is to let the choice-functions be partial. In this case, (88c) comes out undefined, pretty much the same as may be

the case if a definite NP, like *the American King* occurs in the sentence. If so, then clearly choice-function semantics is not equivalent to classical logic of existentials.

It would be recalled that some of the specificity approaches discussed in Section 1.3 assume anyway that indefinites are ambiguous, and that under one construal they carry something like an existence presupposition. Diesing (1992) argues that explicitly, but the other approaches assuming ambiguity (like the D-linking view) are also consistent with this idea. The source of the presuppositional effects of indefinites was never defined in these approaches beyond the level of stipulation, and the choice-function procedure outlined here could be used to provide the missing definition. Indeed, this is the line taken in Kratzer (1995), who adopts the choice-function approach of Reinhart (1992) only for the problem of 'specific' readings and assumes that these functions are partial, and, thus, the relevant indefinites are presuppositional.

I believe, however, that this is a move that should not be taken too hastily. The procedure of choice-function interpretation, as outlined here, applies in a vast variety of contexts. It is the mechanism responsible for all collective construals of plural indefinites, and, in approaches assuming no standard GQ construals for them, it is the only interpretation that indefinites of the relevant type can get. As we saw in Section 1.3, Kratzer assumes a narrower use of choice functions. For example, she argues that there are no intermediate scope construals, so existential closure of the function variable is always only with widest (discourse) scope. But we also saw there that this is not, in fact, the case, and existential closure must be able to apply anywhere.

Furthermore, I argue in Reinhart (1995) that the idea that indefinites are sometimes presuppositional (in the semantic sense of yielding an undefined value when the N-set is empty) was never sufficiently substantiated. In fact, empty-set indefinites create the impression of a presupposition failure only when used as topics. But under that use, this follows from a pragmatic, rather than semantic, approach to referential presuppositions, along the lines of Strawson (1964). On this view, assessment of a sentence starts with the set denoted by its topic, and if that set is empty, assessment gets stuck, an unpleasant experience which one may describe as a presupposition failure.

Allowing indefinites to carry existence presupposition is a serious move, which turns them into strong, rather than weak quantifiers, and disables basic entailments.⁴² It should not be taken without very substantial evi-

⁴² This is shown in Lappin and Reinhart (1989), among others.

dence and motivation. In fact, it is not at all a necessary consequence of the choice-function procedure that (88a), under (88c), is undefined. There are several conceivable ways to avoid this result and allow (88c) to be false, as entailed by classical logic. I outline here two ways, of which I favor the second.

First, in approaches which allow partial functions, it is possible to assume that although choice-functions are, indeed, partial, the value of the sentence depends on how we define the existential quantifier in a three-valued logic. Since we want to keep the classical logic view on this matter, we may assume its definition in (89).⁴³

- (89) $(\exists x)A$ is true iff for some value of x , A denotes *true*, and false otherwise.

On this definition, (88c) is false. There is no value of the f -variable that makes the formula true and this is sufficient to define it as false. This means that (88a) is not ambiguous and its two representations are equivalent.

The next question is the way choice functions work in implications. Under the narrow scope construal of *American king* in (90a) (inside the antecedent of the conditional), the sentence should be true. This, indeed, is derived already. The function variable in (90b) is existentially closed inside the antecedent. Thus, the A relevant for (89) is the antecedent clause. Since the function is undefined, there is no value of the variable that can make it true, and the antecedent comes out as false, by (89). Hence, the implication is true.

- (90)a. If we invite an American king, Max will be offended.
 b. $[\exists f (CH(f) \wedge \text{we invite } f(\text{American king}))] \rightarrow [\text{Max will be offended}]$
- (91)a. $\exists x (\text{American King}(x) \wedge (\text{we invite } x \rightarrow \text{Max will be offended}))$
 b. $\exists f (CH(f) \wedge [\text{we invite } f(\text{American king}) \rightarrow \text{Max will be offended}])$

The interesting case is the wide-scope construal of the existential. Under the classical logic reading (91a) (which will be obtained if we apply QR to a standard GQ), the sentence is false, since there is no American king such that Max can be offended if he is invited or not. Is the same true of (91b)? More generally, the question is whether (92a) and (92b) are equivalent.

⁴³ This line was brought to my attention by Remko Scha (p.c.). He reports that the way Bochvar's (1959) defines external disjunction corresponds to this analysis of the existential.

- (92)a. $\exists x Q(x) \ \& \ (P(x) \rightarrow B)$
 b. $\exists f(P(f(Q)) \rightarrow B)$

Here, the A relevant for (89) is the whole implication. Independently of our problem, it has been debated in systems allowing the undefined truth value, whether when the antecedent of an implication is undefined, the implication should come out true or undefined. (For example, for sentences like *Max will be offended if we invite the present king of France*). Under the second (undefined) decision, the antecedent in (92b) is undefined; hence, the implication is undefined. Given (89), then, the whole formula is false, since there is no value of the variable that yields it true. Under this assumption, then, (91b) is false, and (92a) and (92b) end up equivalent. But under the other view, (91b) comes out as true, just like (90), so (92a,b) are not equivalent. I will soon examine the possibility that this is nevertheless the correct result.

An analysis along these lines (partial choice functions, and (89)) will face difficulties which, independently of our specific problem, are posed to any three-valued logic. (These are surveyed in Winter (1995).) So it is important to observe that, at least for our case – of (indefinites') choice-functions, it is not necessary to allow partial functions into the semantics.

An alternative line, proposed in Winter (1995), is to define choice-functions also when they apply to the empty set. It rests on the fact that we, anyway, assume already that the linguistically relevant choice-functions select sets rather than individuals (i.e. their type is $\langle\langle e, t \rangle, t\rangle$, $\langle e, t \rangle$). All we have to do is define them so that when they apply to the empty set, their value is the empty set. Winter's definition of choice functions is, roughly, as in (93).

- (93) F is a choice function iff for every set S of type $\langle\langle e, t \rangle, t\rangle$:
 a. if S is not empty, $F(S) = X$, where $X \in S$.
 b. if S is empty, $F(S)$ is the empty set of type $\langle e, t \rangle$.

Recall now that whenever an indefinite is interpreted via a choice function, so that it denotes a set, the predicate which takes this value as an argument is lifted to type $\langle\langle e, t \rangle, t\rangle$. In a system like Scha's (1981), which works with such predicates, it is independently necessary to stipulate that they yield 'false' when applied to the empty set. Let us state this in (94).

- (94) The extension of any lexical predicate of natural language excludes the empty set.

With this assumed, (88a), repeated, comes out false also under the choice-

function construal in (88c). (Since $f(\textit{American king})$ denotes the empty set, and $P(\emptyset)$ is false, by (94).)

- (88)a. An American king visited Utrecht.
 c. $\exists f (f(\textit{American king}) \textit{ visited Utrecht})$

Next let us look at the implication case, repeated. The narrow scope construal in (90b) comes out true, as is standard: there is no function whose value can render the antecedent true. Since the antecedent is false, the implication is true.

- (90)a. If we invite an American king, Max will be offended.
 b. $[\exists f (CH(f) \wedge \textit{ we invite } f(\textit{American king})) \rightarrow [\textit{Max will be offended}]]$
 (91)a. $\exists x (\textit{American King}(x) \wedge (\textit{we invite } x \rightarrow \textit{Max will be offended}))$
 b. $\exists f (CH(f) \wedge [\textit{we invite } f(\textit{American king}) \rightarrow \textit{Max will be offended}])$
 (92)a. $\exists x Q(x) \ \& \ (P(x) \supset B)$
 b. $\exists f (P(f(Q)) \rightarrow B)$

However, under the wide scope construal (91b), which has been our focus here, the result is not equivalent to the classical-logic representation in (91a). The antecedent remains false as in (90b), so the implication is true. This means that, in fact, (92a,b) are not equivalent. They yield the same truth value only when the N-set is not empty. When it is, the choice-function interpretation yields for the wide-scope the same value as for the narrow scope.

More generally, this means that, under Winter's implementation, the choice-function interpretation does not generate for indefinites precisely the same set of truth conditions as that generated by an island-free QR. (The same result is obtained also in Winter's (1997) implementation of choice-functions as generalized quantifiers.) Is this good or bad news? This, in fact, is not a conceptual question, but an empirical one. The question is whether English sentences like (90a) do, in fact, have the truth conditions allowed by QR. Specifically, do we actually ever judge them as false? In the case of implication, the judgements required here may be too subtle, since the logical verdict that (90) is true is not easily accessible, anyway, by naive intuitions. So let us look at a negation context instead.

- (95)a. The organizers did not invite two American kings to the party.
 b. There are two American kings that the organizers did not invite to the party.

- (96)a. The organizers did not invite two American linguists to the party.
 b. There are two American linguists that the organizers did not invite to the party.

(95a) is most easily judged as true. (95b) is an English sentence that demonstrates the wide scope reading that (95a) would get under standard (QR) existential construal. (95b) is obviously false. But it is very difficult to read (95a) as meaning the same as (95b). This does not indicate that it is generally difficult for numeral indefinites to get scope wider than negation. This reading is readily accessible in (96a), which can easily be understood as meaning the same as (96b). Possibly, there are other ways to account for this result. But it is, nevertheless, what we would get under Winter's analysis of the truth conditions of choice functions: It does not matter, in fact, what the scope of the empty-set indefinite in (95a) is (i.e. where we apply existential closure). Under both construals it remains true, so in the case of the empty set, a sentence like (95a) cannot be ambiguous.⁴⁴ Winter (1997) discusses several other contexts which support the view that natural language does not, in fact, have the full range of truth conditions predicted by allowing standard GQ existentials to have free scope.

6.5.2. Extensionality

The empty set aside, the analysis should capture all standard properties of the wide scope of existentials. For this, we must make sure that the given functions select always only from the extension of the N-set in the actual world (even when the N-restriction originates in an intensional context). The problem can be illustrated with the question in (97).

- (97) Who wants to marry which millionaire?

Which millionaire here occurs in the complement of *want*. Nevertheless, its scope is marked by the top *who*, so the question cannot be ambiguous, and *which millionaire* only has an extensional construal. But since no movement is involved, and the N-restriction stays in situ, nothing so far

⁴⁴ When it is easy to construe the indefinite as topic, we may get the undefined air for it, which would follow, independently of the semantics of choice functions, along the Strawsonian line I mentioned. What is hard to get is the false reading. Note that in the system I assume, this reading can nevertheless still be generated, by applying QR to a GQ construal of the indefinite (since no island interferes here). But, as mentioned, obtaining covert wide scope (by QR) for such GQ's is, independently, extremely difficult.

guarantees that the function will select a set from the set of millionaires in the actual world.

Technically, this can be captured by defining the range of quantification for f , as in (98).⁴⁵ The set of choice functions is now defined in G . These functions apply to the intension of a given set (of sets), and select an element from the extension of this set in the actual world. (Under Winter's analysis, discussed in (93), P must be of type $\langle s, \langle \langle e, t \rangle, t \rangle \rangle$, and if $\neg P = \emptyset$, then $f(P) = \emptyset$. But I leave (98) open on that, to allow other implementations.)

$$(98) \quad G = \{f \mid \forall P (\neg P \neq \emptyset \rightarrow f(P) \in \neg P)\}$$

P of type $\langle s, \langle e, t \rangle \rangle$, or $\langle s, \langle \langle e, t \rangle, t \rangle \rangle$

This means that the precise representation of, e.g. (99a), should be (99b), rather than the simpler version I used so far. (f is defined to belong to the set in (98). Thus, its argument is an intension and its value is an extension – a philosopher in the actual world.) Similarly, the wh-in-situ of (97) is interpreted as in (100).

- (99)a. Max will be offended if we invite some philosopher
 b. $\exists f (f \in G \wedge (\text{we invite } f \wedge (\text{philosopher}) \rightarrow x \text{ will be offended}))$

- (100)a. Who wants to marry which millionaire?
 b. $\{P \mid \exists x \exists f \in G (P = \neg(x \text{ wants to marry } f \wedge (\text{millionaire})) \wedge \text{true}(P))\}$

All instances of quantification over choice-function variables above should be read in the same way.

REFERENCES

- Abusch, D.: 1994, 'The Scope of Indefinites', *Natural Language Semantics* 2(2), 83–136.
 Baker, C. L.: 1970, 'Notes on the Description of English Questions. The Role of an Abstract Question Morpheme', *Foundations of Language*.
 Barwise, J. and R. Cooper: 1981, 'Generalized Quantifiers and Natural Language', *Linguistics and Philosophy* 4, 159–219.
 Beghelli, F.: 1993, 'A Minimalist Approach to Quantifier Scope', *Proceedings of NELS 23, GSLI, U Mass Amherst*.
 Beghelli, F.: 1995, *The Phrase Structure of Quantifier Scope*, Ph.D. dissertation, UCLA, Los Angeles.
 Beghelli, F., D. Ben Shalom and A. Szabolcsi: 1993, 'When Do Subjects and Objects Exhibit a Branching Reading?', *WCCFL XII*.
 Beghelli, F. and T. Stowell: 1997, 'The Syntax of Distributivity and Negation', in A. Szabolcsi (ed.), *Ways of Scope Taking*, Kluwer, Dordrecht, pp. 71–108.

⁴⁵ I thank Mats Rooth and Remko Scha, for help in formulating (98).

- Ben-Shalom, D.: 1993, 'Object Wide Scope and Semantic Trees', in Lahiri (ed.), *Proceedings of SALT 3*, UCI.
- Bochvar, D. A.: 1939, 'On a Three-Valued Logical Calculus and its Application to the Analysis of Contradictories', *Mate'matičeskij Sbornik*, Volume 4, Quoted in Susan Haak, *Deviant Logic: Some Philosophical Issues*, Cambridge University Press, 1974.
- Chomsky, N.: 1973, 'Conditions on Transformations', in S. Anderson and P. Kiparski (eds.), *A Festschrift for Morris Halle*, Holt, Reinhart and Winston, New York.
- Chomsky, N.: 1975, 'Questions of Form and Interpretation', *Linguistic Analysis* 1(1).
- Chomsky, N.: 1976, 'Conditions on Rules of Grammar', *Linguistic Analysis* 2(4). Reprinted in N. Chomsky, *Essays on Form and Interpretation*, North Holland, Amsterdam, 1977.
- Chomsky, N.: 1986, *Barriers*, MIT Press, Cambridge, Mass.
- Chomsky, N.: 1995, *The Minimalist Program*, MIT Press, Cambridge, Mass.
- Chung, S., W. Ladusaw, and J. McCloskey: 1994, 'Sluicing and Logical Form', *Natural Language Semantics* 3(3), 239–282.
- Cooper, R.: 1979, 'Variable Binding and Relative Clauses', in Guenther and Schmidt (eds.), pp. 131–170.
- Cooper, R.: 1983, *Quantification and Syntactic Theory*, Reidel, Dordrecht.
- Danon, G.: 1996, 'The Syntax of Determiners in Hebrew', M.A. Thesis, Tel Aviv University, available at the URL: <http://www.tau.ac.il/~danon/Thesis.html>.
- van der Does, J.: 1992, *Applied Quantifier Logics*, Ph.D. dissertation, University of Amsterdam.
- Dowty, D.: 1986, 'A Note on Collective Predicates, Distributive Predicates and "all"', in Marshall, Miller and Zhang (eds.), *Proceedings of the Third Eastern State Conference on Linguistics*, Ohio State University, Columbus, Ohio.
- Engdahl, E.: 1980, *The Syntax and Semantics of Questions in Swedish*, Ph.D. dissertation, University of Massachusetts, Amherst.
- Engdahl, E.: 1986, *Constituent Questions*, Reidel, Dordrecht.
- Evans, G.: 1980, 'Pronouns', *Linguistic Inquiry* 11(2), 337–362.
- Farkas, D.: 1981, 'Quantifier Scopepe and Syntactic Islands', *Proceedings of the Seventeenth Chicago Linguistics Society*, pp. 59–66.
- Fox, D.: 1994, 'Economy and Scope', *Natural Language Semantics* 3(3), 283–341.
- Fodor, J. and I. Sag: 1982, 'Referential and Quantificational Indefinites', *Linguistics and Philosophy* 5, 355–398.
- Gil, D.: 1982, 'Quantifier Scopepe, Linguistic Variation and Natural Language Semantics', *Linguistics and Philosophy* 5, 421–472.
- Groenendijk, J. and M. Stokhof: 1982, 'Semantic Analysis of *wh*-complements', *Linguistics and Philosophy* 5(2), 175–231.
- Guenther, F. and S. Schmidt (eds.): 1979, *Formal Semantics and Pragmatics for Natural Languages*, Reidel, Dordrecht.
- Hamblin, C.: 1973, 'Questions in Montague English', *Foundations of Language* (10), 41–55. Reprinted in B. Partee (ed.), *Montague Grammar*, New York: Academic Press 1976.
- Heim, I.: 1982, *The Semantics of Definite and Indefinite Noun Phrases*, Ph.D. dissertation, University of Massachusetts, Amherst, Published in 1989 by Garland, New York.
- Heim, I.: 1986, 'Notes on Comparatives and Related Matters', ms. MIT.
- Hendriks, H.: 1993, *Studied Flexibility*, Ph.D. dissertation, University of Amsterdam.
- Hilbert, D. and P. Bernays: 1939, *Die Grundlagen der Mathematik II*, second edition, reprint 1970, Springer, Berlin.
- Higginbotham, J.: 1985, 'On Semantics', *Linguistics Inquiry* 16, 541–593.
- Higginbotham, J.: 1987, 'Indefinites and Predication', in E. Reuland and A. ter Meulen (eds.), 1987, pp. 41–80.
- Higginbotham, J.: 1992, 'Interrogatives', ms. MIT.
- Hirschbuhler, P.: 1982, 'VP Deletion and Across the Board Quantifier Scope', in *Proceedings of NELS 12*, GLSA, University of Massachusetts, Amherst, pp. 132–139.

- Hornstein, N.: 1994, *LF: The Grammar of Logical Form from GB to Minimalism*, To appear, Blackwell, Oxford.
- Huang, J.: 1982, *Logical Relations in Chinese and the Theory of Grammar*, Ph.D. dissertation, MIT, Cambridge.
- Ioup, G. L.: 1975, *The Treatment of Quantifier Scope in a Transformational Grammar*, Ph.D. dissertation, CUNY.
- Kamp, H. and U. Reyle: 1993, *From Discourse to Logic*, Kluwer, Dordrecht.
- Karttunen, L.: 1977, 'The Syntax and Semantics of Questions', *Linguistics and Philosophy* 1, 1-44.
- Keenan, E.: 1987, 'A Semantic Definition of "Indefinite NP"', in E. Reuland and A. ter Meulen (eds.), 1987, pp. 109-150.
- Keenan, E. and A. Faltz: 1978, *Logical Types for Natural Language*, Working papers in Syntax and Semantics, UCLA, Los Angeles.
- Kempson, R. and A. Cormack: 1981, 'Ambiguity and Quantification', *Linguistic and Philosophy* 4, 259-309.
- Kratzer, A.: 1995, 'Scope or Pseudo Scope? Are There Wide Scope Indefinites?' To appear in F. Hamm and A. von Stechow (eds.), *Proceedings of Recent Developments in the Theory of Natural Language*, University of Tübingen.
- Lappin, S. and T. Reinhart: 1988, 'Presuppositional Effects of Strong Determiners', *Linguistics* 26, 1021-1037.
- Link, G.: 1983, 'The Logical Analysis of Plural and Mass Terms: A Lattice Theoretical Approach', in R. Bäuerle et al. (eds.), *Meaning, Use and Interpretation of Language*, De Gruyter, Berlin.
- May, R.: 1977, *The Grammar of Quantification*, Ph.D. dissertation, MIT, reprinted by IUC.
- May, R.: 1985, *Logical Form: Its Structure and Derivation*, MIT Press, Cambridge, Mass.
- Moltmann, F. and A. Szabolcsi: 1994, 'Scope Interactions with Pair-List Quantifiers', *Proceedings of NEIS* 24.
- Pesetsky, D.: 1982, *Paths and Categories*, Ph.D. dissertation, MIT, Cambridge, Mass.
- Pesetsky, D.: 1987, 'Wh-in-situ: Movement and Unselective Binding', in E. Reuland and A. ter Meulen (eds.).
- Reinhart, T.: 1976, *The Syntactic Domain of Anaphora*, Ph.D. dissertation, MIT, Cambridge, Mass. Distributed by MITWPL.
- Reinhart, T.: 1979, 'Syntactic Domains for Semantic Rules', in Guenther and Schmidt (eds.).
- Reinhart, T.: 1983, *Anaphora and Semantic Interpretation*, Croom-Helm, Chicago University Press.
- Reinhart, T.: 1986, 'On the Interpretation of "Donkey" Sentences', in F.C. Traugott et al. (eds.), *On Conditionals*, Cambridge University Press.
- Reinhart, T.: 1987, 'Specifier and Operator Binding', in E. Reuland and A. ter Meulen (eds.).
- Reinhart, T.: 1991, 'Elliptic Conjunctions: Non Quantificational LF', in A. Kasher (ed.), *The Chomskyan Turn*, Blackwell.
- Reinhart, T.: 1992, 'Wh-in-situ: An Apparent Paradox', in P. Dekker et al. (eds.), *Proceedings of the Eight Amsterdam Colloquium*.
- Reinhart, T.: 1993, 'Wh-in-situ in the Framework of the Minimalist Program', Lecture at the Utrecht Linguistic Colloquium, distributed by *OTS Working Papers*, 1994, TL-94-003. To appear in *Natural Language Semantics*.
- Reinhart, T.: 1995, *Interface Strategies*, OTS working papers, TL-95-002. A revised version will appear in MIT Press.
- Reuland, E. and A. ter Meulen (eds.): 1987, *The Representation of (In)definites*, MIT Press, Cambridge, Mass.
- Rodman, R.: 1976, 'Scope Phenomena, Movement "Transformations"', and Relative Clauses', in B. Partee (ed.), *Montague Grammar*, Academic Press, New York.

- Roberts, C.: 1987, *Modal Subordination, Anaphora and Distributivity*, Ph.D. dissertation, University of Massachusetts, Amherst.
- Ross, J. R.: 1969, 'Guess Who', in R. Binnick et al. (eds.) CLS 5, Proceedings of the Fifth Regional Meeting of the Chicago Linguistic Society, Chicago, Illinois. pp. 252–286.
- Ruys, E.: 1992, *The Scope of Indefinites*, Ph.D., Utrecht University, published in the OTS Dissertation Series, Utrecht.
- Ruys, E.: 1995, 'Weak Crossover as a Scope Phenomenon', ms. University of Utrecht.
- Sag, I.: 1976, *Deletion and Logical Form*. Ph.D. dissertation, MIT, Cambridge, Mass.
- Scha, R.: 1981, 'Distributive, Collective, and Cumulative Predication', in J. Groenendijk et al. (eds.), *Formal Methods in the Study of Language*, Mathematical Center, Amsterdam, pp. 485–512.
- Strawson, P.: 1964, 'Identifying Reference and Truth Values', *Theoria*, vol. 30. Reprinted in P. Strawson, *Logico Linguistic Papers*, Methuen, London (1974), and in D. Steinberg and L. Jakobovits (eds.), *Semantics*, Cambridge University Press, London.
- Szabolcsi, A.: 1995, 'On Modes of Operation', in Paul Dekker and M. Stokhof (eds.), *Proceedings of the 10th Amsterdam Colloquium*, University of Amsterdam.
- Szabolcsi, A.: 1997, 'Strategies for Scope Taking', in A. Szabolcsi (ed.), *Ways of Scope Taking*, Kluwer, Dordrecht.
- Szabolcsi, A.: (ed.), 1997, *Ways of Scope Taking*, Kluwer, Dordrecht.
- Verkuy, H. J.: 1988, 'Aspectual Asymmetry and Quantification', in V. Ehrlich and H. Vater (eds.), *Temporalsemantik: Beiträge zur Linguistik der Zeitreferenz*, Tübingen, pp. 220–259.
- Williams, E. (1977), 'Discourse and Logical Form', *Linguistic Inquiry* 8(1).
- Williams, E.: 1986, 'A Reassignment of the Functions of LF', *Linguistic Inquiry* 17, 265–299.
- Winter, Y.: 1995, 'On the Formalization of Choice-Functions as Representing the Scope of Indefinites', in G. V. Morrill and R. T. Oehrle (eds.), *Formal Grammar, Proceedings of the Conference of the European Summer School in Logic, Language and Information*, Barcelona.
- Winter, Y.: 1997, 'Choice Functions and the Scopal Semantics of Indefinites', *Linguistics and Philosophy* 20(4), 399–466 (this issue).

University of Utrecht
Department of Linguistics OTS
Trans 10
3512 JK Utrecht
The Netherlands