

Monadology, Information, and Physics

Part 1: Metaphysics and Dynamics

Soshichi Uchii
(Kyoto University, Emeritus)

Abstract

Leibniz coined the word “dynamics,” but his own dynamics has never been completed. However, there are many illuminating ideas scattered in his writings on dynamics and metaphysics. In this paper, I will present my own interpretation of Leibniz’s dynamics and metaphysics (which is indispensable for any reasonable reconstruction of Leibniz’s dynamics). To my own surprise, Leibniz’s dynamics and metaphysics are incredibly flexible and modern. In particular, (a) the metaphysical part, namely *Monadology*, can be interpreted as a theory of information in terms of monads, which generate both physical phenomena and mental phenomena. (b) The phenomena, i.e., *how the world of monads appears to each monad* must be distinguished from its *internal states*, which Leibniz calls *perceptions*, and the phenomena must be understood as the results of these *states and God’s coding*. My distinctive claim is that most interpreters ignored this *coding*. (c) His dynamics and metaphysics can provide a framework good enough for enabling Einstein’s special relativity (but of course Leibniz did not know that). And finally, (d) his dynamics and metaphysics can provide a very interesting theory of space and time.

In Part 1, we will focus on the relationship between metaphysics and dynamics. Leibniz often says that dynamics is *subordinated* to metaphysics. We have to take this statement seriously, and we have to investigate *how* dynamics and metaphysics are related. To this question, I will give my own answer, based on my informational interpretation.

On my view, Leibniz’s metaphysics tries, among others, to clarify the following three: (1) How each monad is programmed. (2) How monads are organized into many groups, each of which is governed by a dominant monad (*entelechy*); this can be regarded as a precursor of von Neumann’s idea of *cellular automata*. And (3) how the same structure is repeated in sub-layers of the organization. This structure is best understood in terms of the *hierarchy* of programs, a nested structure going down from the single dominant program (corresponding to *entelechy*) to subprograms, which again controls respective subprograms, and *ad infinitum*. If we

may use a modern term, this is a sort of *recursion*, although Leibniz himself did not know this word.

And one of my major discoveries is that the *same recursive structure* is repeated in the phenomenal world, the domain of dynamical investigations. Recursion of *what*, you may ask. I will argue that it is *elastic collision*. For Leibniz, aside from inertial motions, dynamical changes of motion are brought about by elastic collisions, at *any level* of the infinite divisibility of matter. This nicely corresponds to the recursive structure of the program of a monad, or of the program of an organized group of monads. This is the crux of his claim that dynamics is subordinated to metaphysics. Moreover, the program of any monad is *teleological*, whereas the phenomenal world is governed by *efficient cause* of dynamics. And it is natural that the pre-established harmony is there, since God is the *ultimate programmer*, as well as the creator.

* * * * *

1. Preliminaries

Let me remind the reader of my previous paper on Leibniz (Uchii 2009). In that paper, I presented an outline of Leibniz's *Monadology* as a theory of information: (1) each monad can be regarded as an incorporeal automaton (infinite-state machine) programmed by God; (2) each monad has its own state-transition function governing the whole series of its change; and (3) the *phenomena* which appear to each monad are the result of its internal states *and* the coding God has prepared. I will explain each item in more detail.

(1) *Leibniz's informational turn*

Beginning with *Discourse on Metaphysics* (1686), Leibniz developed his philosophical view, via *New System of Nature* (1695), to *Monadology* (1714). Initially, he concentrated on the notion of *individual substance*, depending on the traditional logic of "subject and predicate," thus claiming that the subject of an individual contains all predicates applicable to that individual in the actual world. However, soon he realized (during the correspondence with Arnauld) that "this complete individual notion involves relations to the whole series of things" (Ariew and Garber 1989, 69). And, as I see, he came to the following view in *New System of Nature*:

For why should God be unable to give substance, from the beginning, a nature or an internal force that can produce in it, in an orderly way (as would happen in a *spiritual or formal* automaton, but *free* in the case where it has a

share of reason), everything that will happen to it, that is, all the appearances or expressions it will have, without the help of any created being? (sect. 15)

Here, instead of the old-fashioned “subject-predicate form,” Leibniz introduced the crucial concepts of “spiritual automaton” and its “transition function” (this is the modern term in information theory, corresponding to the “internal force” in the preceding quotation) which governs the change of its internal state. The word “formal” is related with the Aristotelian “form,” the essential element responsible for the *unity* of substance. By means of these concepts, Leibniz could overcome the constraints of the “subject-predicate form,” and handle the relations of internal states and even the relations among the individuals. But note that “relation” is always *ideal, not real*, according to Leibniz. Each monad is *self-sufficient*, and strictly there are *no communications* (hence no relations) between any two monads. However, Leibniz often allows an *ideal* mode of speech, so to speak, by saying that a monad is *active* or *passive* to another. Later I will clarify this point (from Section 9).

Further, the transition function of each monad can be interpreted as a *teleological law*, since God created and programmed each for attaining a certain *goal*. Even a program made by a human programmer is teleological, since it is a program *for* doing a certain job.

(2) *Whole series of change given at once*

Each individual substance is later called “monad.” And what is crucial here is the following: (i) Monads have *no extension*, and hence *no need for space*. (ii) God gave the whole series of change for each monad *at once*, when He created the world, and hence *no need for time*! In the realm of substances or monads, there are neither space nor time, so that whatever is real is given *without space*, and *atemporally* or eternally! That’s one of the reasons why God could establish harmony among the created monads. And that’s also one of the reasons why Leibniz continually says that space and time are both *ideal*, space and time are only for phenomena, not any part of reality. Then you may wonder: how do space and time arise from the atemporal reality without extension? Thus we now come to point (3).

(3) *Phenomena, space, and time*

In his later *Monadology*, Leibniz characterizes changes of monad (substance) in terms of *perceptions* and *appetitions* (*appetites*). “The passing state which involves and represents a multitude in the unity is nothing other than what one calls perception” (*Monadology*, sect. 14, Ariew and Garber 1989, 214). And, the “action of the internal principle which brings about the change or passage from one

perception to another can be called *appetition*" (*op.cit.*, 215). The "internal principle" is nothing but what I called "transition function," and its "instantaneous action" is *appetition*.

But, here, we have to be very careful. Leibniz's "perception" is different from ordinary perception in our consciousness; it's a *technical* word for expressing a "passing state" of monad. Further, we have to keep in mind that perceptions occur in monads which exist in *timeless* realm! Thus our ordinary perceptions in our consciousness and in time must be sharply distinguished from the Leibnizian technical *perception*.

This distinction leads us to the question of the relationship between the reality and the phenomena. The reality is without space and without time, but the phenomena occur in space and time. To be more specific, physical phenomena (motion, in particular) take place within space and time, and mental phenomena (sensations, feelings, etc.) occur in time, at least. Moreover, it makes good sense to say that *mental phenomena*, such as sensations or thinking, need *spatial concepts* for their description. When I say "I feel a stab of pain in my head," my head of course has a spatiotemporal location! When I say "I think, therefore I am," my thinking occurs in some location. Leibniz himself points this out to de Volder (20 June 1703, Ariew and Garber 1989, 178).

Then we definitely need something *bridging* these two different realms. I claimed, in my previous paper, that God must have used *coding*, from reality to phenomena (how reality *appears* to humans, for instance, or to any other creatures); reality is *encoded*, and we humans have to *decode* in order to know any part of reality.

In addition to the fact that space and time exist *only* in the phenomenal world, take Leibniz's famous claim of *infinite divisibility of matter*. A collection of monads exists behind any phenomenal body with a *spatiotemporal* location; and this correspondence becomes unintelligible without some *coding*, bridging reality and phenomena, two entirely different realms. For, monads are ultimate atoms, *not divisible* at all! Thus you may see one of the essential points of my informational interpretation. In the realm of monads, there are *no quantitative* properties, only qualitative properties. The quantities in the phenomenal world are added, so to speak, by *coding*, when God encoded the realm of monads to the phenomena. Perceptions of a monad do have *real* basis, since they *represent* what is going on in all monads. But when we humans (or any other monads) see phenomena, we see many (qualitative) features of monads in a *disguised* form, containing *quantities* also. This clearly shows that we have to recognize the presence of coding, God's coding

(no one else can provide it!). Representation is not simple mirroring, but can have *various forms*, as long as it can secure a certain *correspondence*. That's what *coding* can accomplish.

Needless to say, the modern reader should immediately understand the need for *coding for programming*. For Leibniz, God is the ultimate programmer, *creating monads, determining what they do, and what their activities appear to each other!* The last *cannot* be identified with *perceptions (states)* of a monad. To repeat, in order to express something by something else, you've got to adopt some *coding*, and (rational) God is no exception!

Since this point is crucial for my informational interpretation, let me illustrate it in terms of a simple symbolism. Let us consider only two monads, *monad-1* and *monad-2*. The first has its own *sequence* of states (perceptions) s_1 and the second has s_2 . Notice that these two sequences are not only different but *incompatible* (within the same monad), because of Leibniz's principle of *identity of indiscernibles* (monads are differentiated only by their states). And when *monad-1* appears to *monad-2*, this appearance *cannot* be the same as s_1 . Thus this appearance must be something like $E(s_1)$, which is an *encoded version* of s_1 . Thus the sequence of states and the sequence of appearances have a *different status*, respectively, in any monad. Hence, we need *decoding* in order to obtain information of reality from phenomena. This illustration is no doubt oversimplified, but it can show the *essential* point. It should be noted that, although a monad's perceptions (states) are themselves a representation, and hence they are encoded, the encoding for *perceptions* and that for *phenomena* must be different; the latter is *doubly* encoded, so to speak. That's the point of my argument.

Now, as De Risi has convincingly argued, Leibniz assumed that there are at least *homomorphisms* (partial isomorphisms) between phenomena and essential features of reality (De Risi 2007, ch. 3). This is perfectly consonant with my own informational interpretation of *Monadology*. For, by expressing a feature of reality in terms of phenomena via some coding, the correspondence between the two realms can be perfectly preserved, *although phenomena may contain something more as well, which does not exist in reality*, e.g., space, time, and infinitely divisible matter.

As regards the nature of space and time, Leibniz repeatedly claimed that "space is an order of coexistences, time is an order of successions," and they appear only in phenomena. This claim has to be reconstructed properly, and, *consistently with* any reconstruction of Leibniz's dynamics. To the best of my knowledge, this task is still largely left to be done, and I wish to make a significant contribution in this field. And, for this task, my informational interpretation can provide a useful framework.

And even at this preliminary stage, it should be clear to the reader that space and time (in the phenomenal world) are the products of certain features of monads *together with* God's coding!

2. Leibniz on Forces

With this background, we can begin to discuss Leibniz's dynamics. His mature views on mechanics and dynamics began to appear around 1686 (the famous criticism of the Cartesian physics). It may be instructive to inquire the reason why Leibniz came to the notion of force, in opposition to the Cartesian view that the essence of body is extension. For this purpose, his paper "On Body and Force, Against the Cartesians" (1702, included in Ariew and Garber 1989, 250-256) is quite instructive. Aside from Leibniz's emphasis on the notion of *living force* (*vis viva*), rather than the Cartesian *quantity of motion* (*momentum*), he spells out another reason for insisting on the notion of force.

According to Leibniz, Cartesians can explain neither the *nature of body* nor the *nature of motive force*. Our experience shows that physical bodies have two kinds of resistance, *impenetrability* and *inertia*. The former prevents, when one body collide with another, that one goes through the other; without this impenetrability, any collision and any change of motion would be impossible. Moreover, any change of motion by collision, the size (mass) of body is relevant, so that the degree of resistance against motion has to be considered. This is, in modern terms, inertia and inertial mass. And Leibniz argues nicely how we should combine these two properties with extension. He points out that extension "signifies a diffusion or repetition of a certain nature" (*op.cit.*, 251). Body has extension just as abstract space has. And Leibniz further points out that "extension" is a relative term which *depends on what is extended, or diffused or repeated*. Spatial extension (length) depends, roughly speaking, on repeated use of unit length (rod), but the extension of a body depends on the preceding *two properties*, and this makes an essential difference from mere spatial extension!

However, resistance alone cannot *begin* any *new* motion. Thus Leibniz introduces *dynamicon*, or the innate principle of change and persistence (*ibid.*). You may suspect that *dynamicon* is twofold, in that *change* and *persistence* are mentioned. However, it may be rash to conclude so. Leibniz indeed say that *dynamicon* is twofold, *active* and *passive*; and these two corresponde to *active force* and *passive force*. But the relationship between "change/persistence" and "active/passive" is not straightforward, as we will see shortly. Anyway, the important point here is that in an extended body, these two kinds of force are inherent, and these two are repeated or diffused all over the same body.

3. *Specimen Dynamicum*

The preceding is Leibniz's own summary written much later (1702) than his paper on dynamics (1695). But this can help us considerably, and we can now proceed to Leibniz's works on dynamics and related subjects. To mention only the most important works, (1) the famous claim of the conservation of force (energy, in modern terms), (2) works on planetary motion (1689-90), and (3) the manuscripts on dynamics (1691-95), of which only a part was published. For Leibniz's earlier works on physics, the reader is referred to Garber's excellent paper (1995), as well as the relevant parts (chh. 2 and 7) of Aiton (1985).

For convenience of exposition, let us begin with (3). The main text is *Specimen Dynamicum* (1695). This paper begins with a paragraph that contains the following striking statement:

... strictly speaking, motion (and likewise time) never really exists, since the whole never exists, inasmuch as it lacks coexistent parts. And furthermore, there is nothing real in motion but a momentary something which must consist in a force striving [*nitente*] toward change. Whatever there is in corporeal nature over and above the object of geometry or extension reduces to this. (Ariew and Garber 1989, 118)

At first, the reader may wonder what this means. But remember what we saw in the preceding Section 1, Preliminaries (2) and (3). In the "strict sense," time does not exist, because the reality is timeless. And, when one says an object x moves from place A to another place B, " x at A" and " x at B" cannot coexist, so that "the whole motion never exists"; this is what Leibniz is saying. Motion is a phenomenon we see in our conscious perception, not any part of reality. However, it has a basis in reality, and this basis can be called a "force striving toward change," which somehow expresses a force in monads (real substances).

With this explanation, it may become easier to understand Leibniz's classification of force into four categories. As we saw in Section 1, (1), a monad is given "an internal force that can produce everything that will happen to it"; this force is called "primitive force." However, the story is not that simple. For, in *Specimen Dynamicum*, this primitive force is divided into the *active* and the *passive*, and the reason for this will be explained shortly. Further, these forces must be reflected in *phenomena*, and therefore, there must be *derivative* forces, *active* and *passive*.

The need for this division is already suggested in Section 2, but we will go into more detail, on the basis of the text of *Specimen Dynamicum*.

In physical phenomena, many thinkers assumed that the concept of *inertia* is indispensable. Thus Newton's First Law is the law of inertia: *By its innate force alone a body will always proceed uniformly in a straight line provided nothing hinders it.* By this property of inertia, a body at rest remains at rest, unless something hinders this state. And Newton's Second Law says that *a force can change the state of rest, as well as the state of motion, and moreover, that the change is proportional to that force.* Further, inertia works together with *inertial mass*, which is the measure of the *resistance against the change of motion.* In addition, the Second Law introduces *acceleration*, the rate of change of velocity when a force is impressed on a body; thus the Newtonian force can be expressed as the product of inertial mass and acceleration, $F = ma$. You may wonder how Leibniz would reconstruct this Newtonian mechanics, and that's exactly the question we address in the following.

Now, Leibniz likewise admits inertia, but also *impenetrability (antitypy)* as essential properties of a body, as we have seen in Section 2; these are the main expressions of the *derivative passive* force. However, he is quite reluctant to admit the notion of acceleration; and here, we may encounter a big obstacle against understanding the Leibnizian dynamics. But before getting into this topic, we have to say what *derivative active* force is. This is a rather hard job, since it is hard to find Leibniz's *unambiguous* and *decisive* texts on this issue, which, *at the same time*, looks reasonable to us, the *modern readers*.

One may suspect that it may be what Leibniz calls *vis viva* or *living force*, which corresponds to kinetic energy in modern terms. Leibniz takes pains for showing that this force is proportional to the *square* of speed (but we may neglect it here). However, we have to notice that the notion of kinetic energy ($mv^2/2$, in modern notation, where m and v are mass and velocity, respectively) involves both *resistance* and *motion*, thus suggesting an amalgamation of *passive and active* forces. Moreover, kinetic energy is a *quantity* of force *resulting from an extended (in time) motion*. Recall that Leibniz is eager to talk about what is *real* in each *instant* of motion (see the preceding quotation). All we can infer may be that the velocity v of motion is essentially related with "active."

Another candidate is *impetus*, and indeed, Leibniz often mentions this, when he refers to derivative active force. However, *impetus* corresponds to the Cartesian notion of "quantity of motion" (but Leibniz's version incorporates the *direction* of motion, i.e., *vectorial* quantity), which is normally expressed as mv . But again, this

involves both *passive and active* elements, to say the least. Moreover, again, Leibniz insists as follows (Ariew and Garber 1989, 120-121):

... we can distinguish the present or instantaneous element of motion from that same motion extended through a period of time ...

... the numerical value of a motion [*motus*] extending through time derives from an infinite number of impetuses ...

Thus, when he said “a momentary something” or “a force striving [*nitente*] toward change,” it must be an *instantaneous (or infinitesimal) impetus*. Then, a derivative active force which exists at each moment, if we adopt this candidate, must be this instantaneous impetus. This proposal does have textual grounds (however, Leibniz seems sometimes sloppy, and for a sympathetic reading, see Bertoloni Meli 1993, 4.3). But this raises a serious problem especially for the modern reader. For, according to the classical (Newtonian) mechanics, *in any uniform (inertial) motion, there is no force!* According to the Second Law of Newton, force is related with acceleration, when a motion *changes* its velocity; thus *no acceleration, no force*. Therefore with this preconception, Leibniz’s insistence on the existence of force, even when a body is moving uniformly, should be unintelligible.

However, in order to remove this difficulty, we have to remember that for Leibniz, “dynamics is subordinated to metaphysics” (his 1702 paper, referred to in Section 2, Ariew and Garber 1989, 252). And my informational interpretation of *Monadology* will be quite helpful in this context. But we will postpone this task for a while (see Section 4), and tentatively adopt the view that derivative active force corresponds to *impetus*. If we are focusing on motion at any instant, derivative active force corresponds to instantaneous *impetus*.

In sum, then, derivative forces are two in kind, the active which *acts on* another, and the passive which is *being acted on*. Motion is an interplay of these two forces. Notice that any change of motion, or rather, any *change of configuration* of bodies, are supposed to be the result of this *interplay* of the two forces. Because of this dual aspects, it is quite difficult to separate completely, in our description of such changes, the active and the passive. For instance, impetus is described as *mv*, a product of mass and velocity, containing both passive and active forces. Likewise, since inertial mass resists any change of motion, in proportion to that mass, both active and passive forces appear in this description. Thus, depending on which aspect we are interested in, the focus is sometimes on the active, sometimes on the passive.

Then, getting back to the realm of monads again, why do we need the distinction of active and passive? Unless a monad is perfect (that is God), it is a created being with limitations (it is limited in the faculties of knowing, and often called a *finite* substance). In a letter to de Volder (June 20, 1703), Leibniz clarifies his position as follows:

Therefore I distinguish: (1) the primitive entelechy or soul; (2) the matter, namely, the primary matter or primitive passive power; (3) the monad made up of these two things; (4) the mass [*massa*] or secondary matter, or the organic machine in which innumerable subordinate monads come together; and (5) the animal, that is, the corporeal substance, which the dominating monad makes into one machine. (Ariew and Garber 1989, 177)

Obviously, the active force comes from the entelechy or soul, the passive from the primary matter. Thus, roughly speaking, the primary active force is responsible for derivative active force, and the primary passive force for derivative passive. However, in the context of dynamics, we have to be more careful, as was pointed out above.

The preceding is Leibniz's classification of force, mainly in terms of his metaphysics. However, when he steps into specific problems of dynamics, he translates these derivative forces into mathematical concepts, and utilizes differential calculus, often with geometrical figures (e.g., Leibniz's works on planetary motion). And in these contexts, several technical concepts are introduced with mathematical connotation.

4. How does Dynamics correspond to Metaphysics?

As we have already seen, the primitive forces of a monad have counterparts in phenomena, i.e., derivative forces. And Leibniz repeatedly insists that dynamics is indispensable for knowing reality, the realm of monads. So here is a key for understanding Leibniz's view, and removing the preceding difficulty mentioned in Section 3. As I have already suggested in Section 1, there are homomorphisms (via coding) between the realm of monads and the realm of phenomena. De Risi's excellent work (2007) clarified the significance of *Analysis Situs* (Leibniz's work on geometry); this is a new branch of geometry based on analysis of situations, and focusing on *qualitative* aspect. In phenomena, *coexistent* bodies can have various relations with each other, and a "situation" is, roughly speaking, a set of such relations. In the preceding Section 3, I have used the word "configuration of bodies," in order to suggest "situation." (This word is borrowed from Julian Barbour's illuminating discussion of the "Machian problem"; see Barbour 2001, 7-10. A more popular exposition is in Barbour 2000, ch. 5)

But why is this important? Because, bodies correspond to a set of monads, and hence a *situation* involving many bodies provides us with information of the relations among those monads. All right, then, *what kind* of information? The *qualitative, and not quantitative*, information of situations. Space and time are products of *coding*, and they are loaded with quantitative information (metric), such as distance or length of duration. Since such quantitative information has nothing to do with the realm of monads, Leibniz tried to create a new branch of geometry that captures qualitative features of geometry. That way, essential relations among monads can be more conspicuously represented.

Moreover, any *changes of situation* correspond to *motions* of those bodies. In other words, motions are *changes of situation* through time. Leibniz was clearly aware of the importance of combining geometry and dynamics. In his 1702 paper on body and force, after pointing out that there must be *dynamicon* (innate principle of change and persistence) in body, Leibniz continues as follows:

From this it also follows that physics makes use of principles from two mathematical sciences to which it is subordinated, geometry and dynamics. ... Moreover, geometry itself, or the science of extension, is, in turn, subordinated to arithmetic, since as I said above, there is repetition or multitude in extension; and dynamics is subordinated to metaphysics, which treats cause and effect. (Ariew and Garber 1989, 251-252)

In this context, Leibniz seems to mean by “geometry” *Analysis Situs* mentioned above. It begins with the notions of congruence and similarity, and tries to construct a system of geometry independent of *analytical* geometry. We have to notice in the preceding quotation, Leibniz mentioned *arithmetic* rather than analysis, and mentioned *repetition* as his reason. This implies, among other things, that the quantity of extension (e.g., distance) can be constructed and measured by *repeated use* of unit rod (each use is *congruent*), and hence *arithmetic*, rather than analytical mathematics is in order. For a thorough study of Leibniz’s *Analysis Situs*, the reader is referred to De Risi (2007).

Now, let us get back to the main line of my argument. According to my informational interpretation, the *state-transitions* of monads underlie these changes of situation, motions. And recall that the state-transitions of any monad are governed by the primary active force due to entelechy. Thus, this is the *decisive* reason for Leibniz to insist on the existence of derivative active force, in *any changes* of situation (i.e., motion), even when these changes are *inertial* motions with *no* changes of velocity. See the following Figure 1. When three objects A, B, and C moves inertially to A', B', and C' respectively, the situation obviously changes, as the two triangles are quite different (notice this difference is *qualitative*). If one grasps this point, one can see that Leibniz is perfectly consistent, and *within* his theory of dynamics, there *must* be the difference of the notion of force from the Newtonian force. Thus the apparent difficulty mentioned in the preceding section is removed.

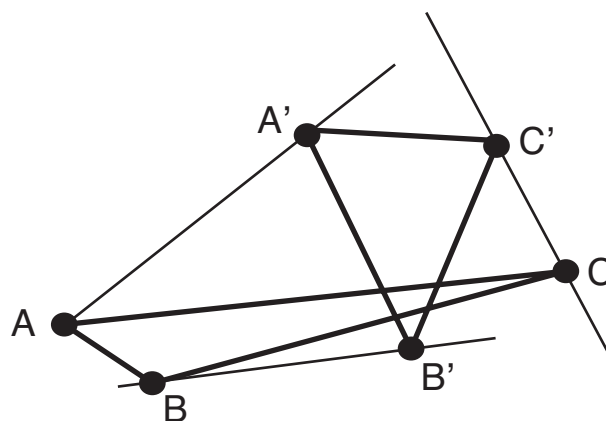

Figure 1: Inertial Motions change Situation

However, we also have to notice that the state-transition of a monad involves *both* active and passive force, because of the *dual* nature of the monad: it has both activity and passivity. Therefore, even though the notion of *impetus* is expressed in terms of both m (mass, due to passive force) and v (velocity, due to active force),

there should be no problem. The same dual nature is reflected in phenomena, and in dynamics which describes these phenomena.

5. Living Force and Dead Force

In *Specimen Dynamicum* (1695), his famous distinction between *living force* and *dead force* is stated and illustrated (not in terms of analytical method) by a few examples, including centrifugal force, gravity, and elasticity. But more technical treatment was established and used several years before, in his paper on planetary motion, *Tentamen de Motuum Coelestium Causis* (1689, abridged as *Tentamen* henceforth). This paper, and all related works have been thoroughly studied by Bertoloni Meli (1993), and I will heavily depend on his study. We can see that Leibniz, drawing on this previous paper, summarizes and explains in non-technical language, some of the main results obtained by a more rigorous and analytical method.

Living force corresponds to kinetic energy (in modern terms), but *dead force* looks very strange to the modern reader: it is “an infinitely small urge,” or *solicitatio*, to motion. The idea is that by adding such urges repeatedly (notice “repetition” again), the speed of any motion increases. Notice that *both* living and dead forces are *active*, since they are essential for *change*. This is the way Leibniz chose for describing motion, *in conformity with his metaphysical concept of force*, “a force striving [*nitente*] toward change.” As a result, Leibniz’s dynamics may look strange, and harder to understand than the standard Newtonian mechanics, with the concept of force in terms of mass and *acceleration*. However, acceleration can be reconstructed, as a macroscopic effect of repeated increment of speed, in terms of *solicitatio*, infinitely small urge.

I think the best example for illustrating Leibniz’s way of constructing dynamics comes from his later writing, titled *Illustratio Tentaminis de Motuum Coelestium Causis* (1705, abridged as *Illustratio*). The reader should be quite familiar with the motion of free fall, an example of *uniformly accelerated motion*. How does Leibniz reconstruct this motion in terms of dead force, obtaining finally a motion with acceleration, speed, and living force?

To illustrate this problem, let me adapt Leibniz’s third figure in *Illustratio*. More technical reconstruction in terms of differential calculus has been masterfully made by Bertoloni Meli (1993), chapter 4, including curvilinear motions.

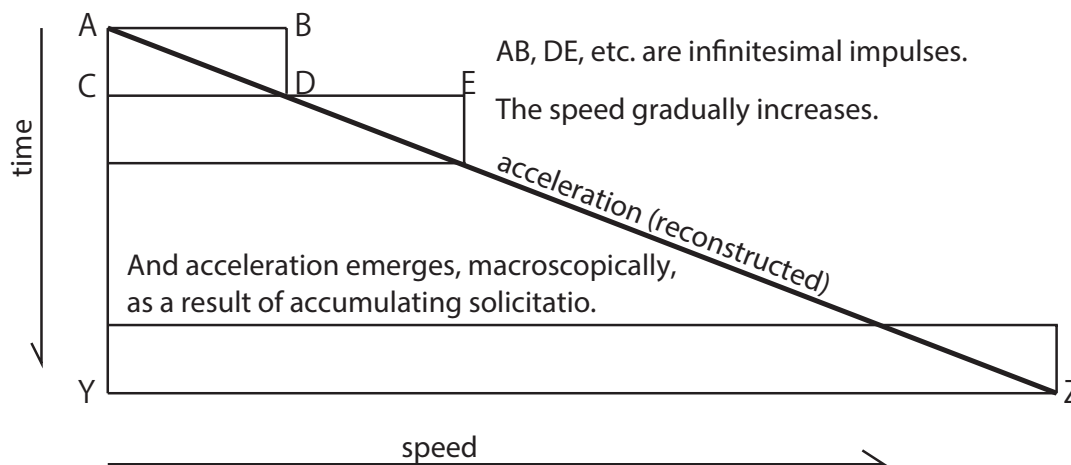

Figure 2: Leibniz's reconstruction of Acceleration

In Figure 2, time flows from top to bottom, and the increment of speed is expressed by a horizontal line. An urge to change, *solicitatio*, is an infinitesimal quantity; but in the Figure, a short line is used, meaning an infinitesimal amount of increment, called impulse. Leibniz believes that gravity (which is a kind of dead force, according to Leibniz) is due to impulses from ether surrounding and penetrating objects, such as earth or moon; so that he means that such representation of motion as this Figure is closer (*qualitatively closer*, say) to actual phenomena, than the Newtonian picture in terms of *continuous* attraction and acceleration (see Section 7). Although several authors criticized that Leibniz didn't have any correct understanding of the relationship between dead and living force, Bertoloni Meli has argued against them, and convincingly reconstructed Leibnizian dynamics of planetary motions in terms of analytical method (Bertoloni Meli, 1993, chh. 4-6). Since *Specimen Dynamicum* is written in a non-technical way, the reader may often be misled. That's the reason why I presented Figure 2, to help the reader's intuitive understanding.

Moreover, as Bertoloni Meli (1993, 88) has pointed out, there is a clear evidence that Leibniz had the correct understanding of the relationship between dead and living forces (recall that these two forces are both *active*). In an undated letter to de Volder, written at least after November 1698 (Gerhardt vol. 2, 153-163), he discussed the motion of free fall, and pointed out the relationship between the *solicitatio* of gravity and the *living force* of a falling body, as follows.

Accumulation of *solicitatio* increases the amount of speed, as we have already seen in Figure 2. And the body continues to fall with increasing speed. Thus, the *solicitatio* needs *time* to increase the speed, and the body needs *time* also, for falling with the increased speed (thus, *square of time!*). So let *solicitatio* be expressed by

infinitesimal dx , speed by x (which *increases* with time); then, in order to obtain the living force of the body, we have to consider some quantity that depends on the *square of time*, and that quantity is nothing but the *distance* the body has fallen; in short, the *square of speed*, the crucial quantity, is obtained, technically by an integration of product of *solicitatio* and (infinitesimal) distance. Since Leibniz often ignores constant factor, he uses “ x^2 ” for expressing living force, in the letter to de Volder. Of course this corresponds to the *kinetic energy* of classical mechanics (in the standard notation, $mv^2/2$).

In this way, Leibniz’s dynamics can reconstruct Newtonian mechanics, starting from a different set of basic concepts. For, Newton’s First Law (of inertia) is supported by Leibniz, and also Third Law (equality of action and reaction). And, unlike Newton, Leibniz emphasizes the notion of *living force* (corresponding energy), which can be obtained by *repetition* and accumulation of dead force, expressed by *solicitatio*. Schematically, “dead force \rightarrow *impetus* \rightarrow living force”; thus I think we should include *solicitatio* into derivative active force, as well as *impetus*.

However, Leibniz was consistently opposed to Newton’s Law of Gravitation, which apparently assumes “action at a distance.” Leibniz tried to explain gravitation, sometimes in terms vortices, at other times by interactions between a body and the surrounding ether, but his attempts remained a mere hypothesis. But before discussing such problems, we have to see Leibniz’s treatment of elastic collisions, and his analysis of elasticity itself. Despite the appearance of “old-fashioned topic,” Leibniz’s discussion of elasticity, if combined with his metaphysical view, contains remarkable ideas and insights, as we will see shortly.

6. Collisions and Relativity of Motion

First, we have to remember that, for Leibniz, a material body is a *well-founded phenomenon*, resulting from a set of innumerable monads. In Leibniz scholarship, there are unsettled controversies over the nature of body, but we do not have to worry about them. All we need is that a body has a good basis in the realm of monads (via coding, of course), and a body is *infinitely divisible*, according to Leibniz.

From these two assumptions, it follows that any material body has an *internal structure* (indeed an infinity of layers, so to speak), which cannot be exhausted in the realm of phenomena; hence Leibniz refuses atomism, as regards the physical (phenomenal) world. And at any stage of that structure, derivative forces (active and passive) are working. If we keep this in mind, Leibniz's discussion of collisions and elasticity becomes much easier to understand.

Now, Leibniz's discussion of collisions and elasticity begins in Part 2 of *Specimen Dynamicum*. He asserts again that "force is something absolutely real, even in created substances"; so that, he means, the study of motion, dynamics can touch on what is real by dealing with the laws governing (derivative) forces in bodies. In contrast,

motion as it is taken to contain only geometrical notions (size, shape, and their change), is really nothing but the change of situation, and ... *as far as the phenomena are concerned, motion is a pure relation, ...* (sect. 37, Ariew and Garber 1989, 130)

He points out that this leads to the "equivalence of hypotheses," the relativity of motion, in our words. As regards this idea, he owes a great deal to his teacher, Huygens (see Barbour, 2001, 462-468).

From this follows ..., that *the equivalence of hypotheses is not changed even by the collision of bodies with one another*, and thus, that the laws of motion must be fixed in such a way that the relative nature of motion is preserved, so that one cannot tell, on the basis of the phenomena resulting from a collision, where there had been rest or determinate motion in an absolute sense before the collision. (*ibid.*)

Consequently, Leibniz concludes "that *the mutual action or impact of bodies on one another is the same, provided that they approach one another with the same speed*" (*ibid.*).

Further, Leibniz draws two more consequences from his notions of bodies and forces: (1) what happens in a body (or substance) can be understood to happen spontaneously and in an orderly way, and (2) no change happens through a leap (the principle of continuity). Then, comes an example of collision.

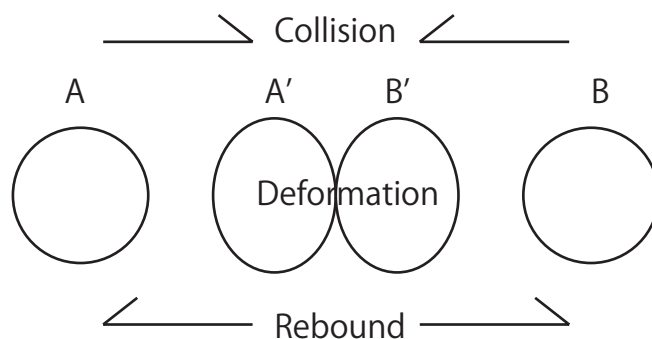

Figure 3: Collision of Two Bodies

Suppose two bodies A and B collide on a straight line, and then rebound (here, it may be assumed that the two bodies have the same mass; another case where this assumption is dropped will be discussed in Figure 4). Leibniz argues that the change of motion can neither happen instantaneously nor discontinuously. When the two bodies collide each other, both begins to deform continuously, and the relative speed of the two decreases until it becomes zero and the internal pressure (due to deformation) becomes maximal. Let this state be A' and B'. The change from A to A' must be continuous, and likewise for B and B'. Then rebound begins and its force is due to the internal pressure, that is, the (relative) motion of the two bodies is transformed into their elastic force, and then released as the driving force of rebounding to the opposite direction, again continuously. See Figure 3 (I have changed Leibniz's original Figure, in order to make it simpler).

Thus it is clear that the *living force* of motion (before and after the collision) is closely related with the force due to *elasticity*. When A and B are at rest with each other (A'B'), the living force before the collision has been transformed into the dead force of elasticity; and then as rebounding motion begins, the dead force (*solicitatio*) of elasticity is released, and the speed increases until the deformation disappears. If A and B are equal in size (mass), rebounding motion recovers the same living force as before. Deforming and rebounding occur *spontaneously* and in an orderly way, Leibniz says.

But what does “spontaneously” mean here? In any monad, any change of its state occurs spontaneously and in an orderly way. But in the context of dynamics, we are dealing with a phenomenal motion. And Leibniz is saying that every active or passive state of a body is spontaneous, arising from an internal force, even if occasioned by something external (Ariew and Garber 1989, 134). Thus he says:

that *in impact, both bodies are equally acted upon, and equally act*, and that half the effect arises from the action of the one, and half from the action of the other. (Ariew and Garber 1989, 135)

In short, because of the relativity of motion, the law of collision depends only on the relative speed of collision, irrespective of motion or rest of colliding bodies, and if the collision is elastic, *the conservation of living force holds for each body*, taken by itself.

But, of course, the reader may feel that it is too rash to generalize from the preceding simple example. So, let me supply an additional example (not in *Specimen Dynamicum*), basically due to Huygens (see Barbour, 2001, 9.4-9.5, for an excellent exposition of Huygens’ theory of collisions). He was Leibniz’s teacher of mathematics in Paris, and he was one of the first who gave brilliant results on the problem of collisions. Suppose two objects, one is larger (its mass is greater) than the other, collide on a straight line (to make the example as simple as possible). We can describe this collision, from the point of view of what Leibniz called *common center of gravity* (*op. cit.*, sect. 51. The modern term is “center of mass.” See Barbour 2000, 80). See the following Figure 4, and let us consider the motions of this system (we consider only these two objects, for the sake of simplicity). Notice that the center of gravity *does not change* during the whole process of collision and rebound; moreover, this center coincides with the point of contact of the two objects, when the elastic stress (deformation) is maximal. Then, viewed from this center, the two objects approach this center with respective velocities, collide, and *rebound with their velocities reversed and undiminished!* Thus the kinetic energy of each, *viewed from this center*, is conserved individually. This is basically one of Huygens’ discoveries, and when Leibniz made the preceding claim that the living force of each object is individually conserved, he must have grounded this claim on such discoveries as this.

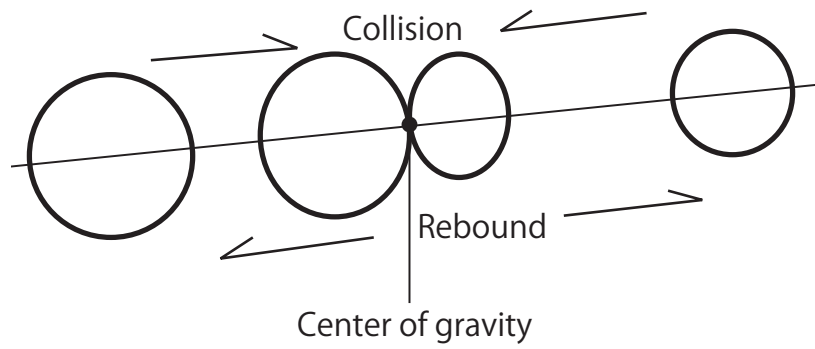

Figure 4: Collision and the Center of Gravity

Now it may not always be the case that collisions are like this, and there may arise a case the deformation by collision does not recover completely. But then, Leibniz claims that the seemingly “lost” living force is transformed into another form, within deformed bodies. This problem will be discussed later (Section 8), when we examine Leibniz’s distinction between *total* and *partial*, as regards living force.

7. All Motion is Rectilinear or composed of Rectilinear Motions

Towards the end of *Specimen Dynamicum*, Leibniz repeats an important claim, which probably first appeared in his paper on planetary motion, *Tentamen* (1689). Since this claim is indispensable (whether or not you like it) for understanding Leibniz's theory of motion, let me quote:

Also, since only force and the *nisus* [effort] arising from it exist at any moment (for motion never really exists, as we discussed above), and since every *nisus* tends to in a straight line, it follows that *all motion is either rectilinear or composed of rectilinear motions*. (Ariew and Garber 1989, 135)

This is the true reason why he tried to dispense with Newtonian notion of acceleration, and to reconstruct acceleration and curvilinear motions, in general, in terms of rectilinear motions, including *solicitatio* which is a mathematical expression of *nisus*. Recall the Figure 2 in Section 5. He consistently adheres to his metaphysical view. Thus, if one ignores this point, Leibniz's dynamics may look cumbersome or even unintelligible. And, we cannot deny that, because of this feature, Leibniz's dynamics became much harder to understand than the Newtonian mechanics, especially to the modern reader. Nevertheless, his dynamics is, on a closer look, consistent and moreover nicely connected with metaphysics, which is, on my reading, nothing but a *theory of information* in terms of monads. This novelty is really amazing.

8. Living Force: Total and Partial

Another important feature in *Specimen Dynamicum* is the distinction between *total* and *partial* living force. Partial force is further divided into (a) “relative / proper” and (b) “directive / common”: (a) belongs to the parts, and (b) is common to the whole. What does this distinction mean, and what significance does it have?

Relative or proper living force is simply the *force of interactions* between the parts (of a single body), and directive or common force is the force that which contributes to the determination of the *relative velocity* (speed and direction) when two bodies collide. Further, Leibniz means that (a) plus (b) equals the *total living force* of a body.

Now, this is not a mere “pedantic” distinction. In the classical mechanics, the kinetic energy of a body is determined by its mass m and velocity v , i.e. $mv^2/2$. But

Leibniz is saying, in effect, that aside from the kinetic energy of a moving body, we also have to consider its *internal energy*, and that is (a)! Thus, if any deformation caused by collisions or any other ways does not recover, and if the living force of a body may seem to be lost, Leibniz can refer to this *partial (relative) living force*.

Notice that, according to Leibniz, a body is *infinitely divisible*, and at any stage of division, *motions of parts* exist *within the body*. This view is really amazing in that it may be regarded as a precursor of Einstein’s notion of “rest energy” (Einstein 1905b), $E = mc^2$ (c is the velocity of light). But, of course, in order to substantiate this claim, we have to examine Leibniz’s metaphysical view also. Let us turn now to Leibniz’s metaphysics, *Monadology*. (In order to discuss the relevance of Leibniz’s dynamics to Einstein’s theory of special relativity, we have to clarify the scope of his dynamics, together with his theory of *space and time*; so that we still have to wait.)

9. Active vs. Passive in *Monadology*

When we turn from Leibniz's work on dynamics, *Specimen Dynamicum*, to *Monadology*, the last summary of his metaphysics, we are somehow puzzled by the *absence* of the word "force," which was crucial in dynamics. There is only one section (48), where the word "power" appears. Instead, the pair of "active/action" and "passive/passion" appears frequently. Thus we have to understand that Leibniz is continuing his discussion of "active force and passive force" in a somehow different terminology. Recall his descriptions of dynamical interaction in terms of "act on" and "to be acted on." Therefore, despite the difference of terminology, we have no reason to suspect that Leibniz abandoned the concept of force in his later metaphysics.

As I understand, Leibniz is promoting his "informational turn" of 1695, and in *Monadology*, he seems to be emphasizing the *informational* features, and thus the concepts relevant to dynamics are now hidden from the foreground. This is presumably the reason why he characterizes the distinction between active and passive, in terms of *perceptual distinctness*. Here are two typical statements (Ariew and Garber 1989, 219):

The creature is said to *act* externally insofar as it is perfect, and *to be acted upon* [*patir*] by another, insofar as it is imperfect. Thus we attribute *action* to a monad insofar as it has distinct perceptions, and *passion*, insofar as it has confused perceptions ... (sect. 49)

And one creature is more perfect than another insofar as one finds in it that which provides an *a priori* reason for what happens in the other; and this is why we say that it acts on the other. (sect. 50)

But, of course, this manner of speaking is only *ideal*, since there are neither mutual communications nor influences between monads, in reality; God manipulates them, *as if* there are mutual influences, via His *programming*.

Now, in the preceding two statements, there is an important problem to be clarified. First, Leibniz presents (1) the distinction between *perfect* and *imperfect* monads. Second, he refers to (2) the distinction between *distinct* and *confused* perceptions. Third, he evokes (3) the distinction between "act on" and "to be acted on" among monads. Fourth, (4) he states, as a basis of saying that a monad is "more perfect" than another, that "something being an *a priori* reason for what happens in

another." Offhand, it seems hard to see any clear connections among these four distinctions.

As regards (1), Leibniz suggests another sense, somehow different from the sense related to (2). In sections 41 and 42 of *Monadology*, he says "God is absolutely perfect---*perfection* being nothing but the magnitude of positive reality," and that "creatures derive their perfections from God's influence, but they derive their imperfections from their nature." This magnifies our problem: how are *distinct perceptions* related with *perfection* of these sections?

It seems that Leibniz is talking about *absolute sense* of perfection, when he refers to the perfections of God and creatures, in sections 41 and 42. Whereas when he tries to define perfection in terms of distinct perceptions, he seems to *relativize* the notion of perfection. For instance, a monad is more perfect than another in such-and-such respect, but it may be more imperfect than another, in another different respect. For it is quite natural that some of a monad's perceptions are more distinct and others are more confused, in comparison with another monad's perceptions. Moreover, this relativization is consonant with the relativity of "act on" and "to be acted on"; a monad, or a body (in phenomena), sometimes can act on another, and it may be acted on by another at other times. As we have already seen, in elastic collisions, one body act on, and is acted on, by another, so that action and passion are mutual. So, for a while we will try this reading, and we will see the results soon, after my presentation of details of my informational interpretation.

However, even at this stage, one thing is clear. The relative sense of perfection (according to my tentative reading) is obviously *informational*, in that it is dependent on distinctness of a perception, a state of a monad. Distinctness suggests that informational content of perception is well-articulated, more informative; confusedness suggests the contrary, i.e. more noise, less informative. And we have to keep in mind that the created monads are *all* limited in the capacity of perception.

Monads are limited, not as to their objects, but with respect to their knowledge of them. Monads all go confusedly to infinity, to the whole; but they are limited and differentiated by the degrees of their distinct perceptions. (section 60, Ariew and Garber 1989, 220-221.)

Then, one feature of the relative perfection may be (a) more informative. But this alone does not seem to serve as a basis of saying that one *acts on* another, i.e., (3)

above. No doubt, “action” is a crucial key word for Leibniz, both in dynamics and metaphysics.

In view of this, (4) seems much better in that it refers to “a reason for what happens in the other.” In dynamics, the motion of two bodies in collision was explained, according to Leibniz, as follows: “that in impact, both bodies are equally acted upon, and equally act, and that half the effect arises from the action of one, and half from the action of the other” (see Section 6). Thus action and passion are mutual, which clearly shows the *relativity* of action. And his explanation referred to active and passive forces, the “innate principle of change and persistence.”

I think we should take Leibniz’s explanation seriously. He was saying, in effect, that after the contact of two bodies in this collision, each body changes according to *its own forces of action and passion*, that is, deformation, rebound, and then modified motion with a constant velocity. This must be interpreted as the change according to the law of dynamics, without evoking the teleological laws of monads.

But this was a story in the *phenomenal world*. What story is there, in the realm of monads, corresponding to this? The changes in the monads must be the ultimate basis for what happens in the phenomenal world. And in this context, Leibniz is talking about “more perfect,” “action and passion,” and “*a priori* reason” for saying one monad is more perfect, acting on another.

Here, the word “*a priori* reason” strikes me. Since this is the most important clue for clarifying the relation between active and passive, let me dwell on this point. As we have already seen, the monads are created and *programmed* by God, *as if* there were mutual communications among them, but in reality each is self-sufficient, changing its state spontaneously according to its own *transition function* (programmed by God). God’s programming is the ultimate source of the pre-established harmony. Thus, Leibniz’s qualification “*a priori*” becomes quite natural, if he has the *program of each monad* in his mind. Leibniz, of course, *did not have* this word “program,” but what he says about primitive active force, the internal principle for changes of state, perfectly matches what we mean by “program” or “transition function.” Above all, any *activity* (source of changes) and *passivity* (resistance to change) of a monad should originate from its program or transition function.

Now, although he refers to “distinct perceptions” many times, it seems rather hard to make sense of this reference. Since a perception is a mere transitory state of monad, it determines the next state *only together with its transition function*, and the *source of change* is in the latter, its operation being called *appetition* (see Section 1, (3);

this is already pointed out in Adams 1993, 380). Therefore, if we wish to talk about any “a priori reason” for what happens in one monad and another, we are *inevitably* led to transition functions and appetitions. As was actually the case with dynamic collisions, any change must be seen as a *process*, rather than as an instantaneous event. This makes our task much easier, and I think this is one of the virtues of my informational interpretation.

But in order to continue my exposition, let me insert a brief note on the structure of programs. Taking a simplest example of programming, let us see how a Turing machine is programmed, and how it works. This will help a great deal, in order to understand what Leibniz is trying to say, *without* using the terminology of the theory of information in the 20th and 21st century. (If the reader is familiar with this, just skip the next section. For all those who are unfamiliar with this topic, let me advise that learning the theory of information is quite useful for understanding Leibniz’s metaphysics! In this connection, I am delighted that Davis’ book (2011) on Turing begins from Leibniz!)

10. The Structure of a Program: Turing Machine

Alan Turing's famous paper (1936) on computability introduced an imaginary machine, later called "Turing Machine," consisting of a *control unit* (an automaton that can have only a finite number of states, i.e., a finite automaton) with a tape-head, and an *infinite tape* that can store discrete information (0 or 1) on each square of it. It can (1) "read" the square under scan, (2) "write" 1 or 0 ("erase" 1 on the square), and (3) "move" either to the right square or to the left square. Each natural number can be *coded* on the tape; for instance, zero by single "1" (other squares are all "blank (0)", the tape-head on the immediate left square of the marked one. Likewise, any n -tuple of natural numbers $\langle m_1, \dots, m_n \rangle$ can be represented (encoded) on the tape, e.g., by a sequence of n groups of marks, a blank square in between two groups playing the role of "comma," but details do not matter, for our purpose. The important point is that the whole system (including the tape) is an *infinite-state* machine, although the control unit is a finite machine. This means, it is *possible* for this machine to store *potentially* infinite amount of information, because of the infinite tape. See Figure 5.

A Turing Machine with a Tape encoding "zero" as its input



Figure 5: Turing Machine

Later, Hao Wang (1957) proposed a "program-version" of this machine. Instead of what a machine *does* and what it produces as the final result, Wang focuses on its *program*, a sequence of instructions. The primitive instructions are only 6 in kind, as follows:

right: go to right (one square)

left: go to left (one square)

mark: write "1" (if "1" is there, leave it as it is)

erase: erase the mark on the square (if no mark, leave it as it is)

transfer to k: if "1" is on the square, jump to the k -th instruction

stop:

A program is a sequence of these instructions, and the last instruction must be “stop.” Of course, there must be a certain grammar in any program; e.g., in order for “transfer to k ” to be meaningful, the program has to contain at least k instructions. This instruction of “transfer” is very important, because this is the key for *recursion*, as we will see shortly. But again, details do not matter for our purpose.

Most Leibniz scholars may be disappointed by this Turing machine. But I am not saying that a monad is a Turing machine. All I wish to say is that to know the structure of a program for this machine is quite illuminating for understanding *many* of Leibniz’s important texts. Let us see what a Turing machine does, when it is given an initial configuration (input) on the tape. For instance, suppose given a natural number m (*encoded* on the tape), program P starts and ends with an output n . This can be written as follows:

$$m \ P \rightarrow \ n$$

This is not interesting. But if this program P is such that, *given any natural number n , it ends with the value of the function f , i.e., $f(n)$, as its output*, we can say “ P computes function f ,” and this is certainly significant. For instance, if, for *any* n ,

$$n \ S \rightarrow \ n+1,$$

then S computes the successor function $f(n) = n+1$. This is of course a function with one variable, but we can easily handle a function with any finite number of variables, and write a program that computes that function. Thus, a computable (i.e., Turing computable) function can be represented by a program that computes it. In essence, this is the definition of *computability* in terms of a program for the Turing machine.

In order to accomplish this task, all we need is a few more procedures. It is easy to *compose* a more complex program from two or more subprograms. If we have two programs P and Q such that

$$n \ P \rightarrow \ f(n) \quad \text{and} \quad n \ Q \rightarrow \ g(n),$$

we can compose larger programs (“stop” instruction must be deleted for the first program) $\langle P, Q \rangle$ and $\langle Q, P \rangle$, and the order of programs makes a big difference:

$$n \ \langle P, Q \rangle \rightarrow \ g(f(n)) \quad \text{and} \quad n \ \langle Q, P \rangle \rightarrow \ f(g(n)).$$

Thus we easily see that a *hierarchy* of functions, *f* within *g* and *g* within *f*, can be represented by an *ordered composition* of programs.

Next, we need a program for deleting a part of input. Given $k+1$ numbers (in encoded configuration on the tape), this program E_1 deletes the first item:

$$n, m_1, \dots, m_k \ E_1 \rightarrow m_1, \dots, m_k$$

This program is not trivial but indispensable, because, without it, we have no means for deleting unnecessary information. In order to make something conspicuous, one has to delete other things. In order to show the final output, we have to delete whatever remains in the process of computation (and our *coding* requires that).

Finally, we need a program which constitute an essential part of recursion, that is, *repeating* something and *accumulating* results. This program $I(P)$ *iterates* program P , n times (n is a specified number). Supposing P acts on an input m (which may be an ordered set of k numbers), and ends with output $f(m)$,

$$n, m \ I(P) \rightarrow n, f^n(m) \text{ where } f^n(m) \text{ is the result of repeated computation of the same function } f, n \text{ times, } f(f(\dots f(m)\dots)).$$

The power of recursion becomes powerful, when this program is applied to *itself*, thus when *nested recursion* occurs. For instance, although successor function (its program version is S) may look trivial, if you iterate this m times, you can accomplish addition $n+m$. This can be shown as follows: Suppose S is applied to input n . Then you obtain $n+1$.

$$n \ S \rightarrow n+1$$

So, next, suppose $I(S)$ is applied to input m, n ; then S (applied to n) is repeated m times, and the result is:

$$m, n \ I(S) \rightarrow m, n+m$$

Thus by adding program E_1 , the larger program $\langle I(S), E_1 \rangle$ can compute addition $n+m$.

Multiplication can be obtained by *repeated* addition, thus another recursion (i.e., a recursion of another recursion). But we need a little technique. First, let us notice the following chain of operation:

$$n, 0 \ I(S) \rightarrow n, n \ I(S) \rightarrow n, 2n \ I(S) \rightarrow n, 3n \dots$$

Thus, if we repeat this process m times, mn can be obtained. $I(S)$ is applied to input $n, 0$. And since we wish to repeat this application m times, $I(I(S))$ must be applied to input $m, n, 0$. That is,

$$m, n, 0 \ I(I(S)) \rightarrow m, n, mn$$

Then, by deleting the first two numbers, the final output can be made the result of multiplication. However, we wish to start from input m, n , not a triplet. So, starting from the pair, just add the third element 0 at the outset (making a *new entry*, so to speak, for storing the result of computation); then apply $I(I(S))$. This composition makes a perfect program for multiplication.

This is enough for our purpose. But I wish to emphasize this: If you think this is *merely* an elementary lesson of arithmetic, you are wrong! Later, I will argue that Leibniz was trying to construct his dynamics on the foundations of arithmetic, geometry of situations, and his theory of information (*Monadology*). Notice that arithmetic is certainly abundant in recursion. This is my conjecture, but Leibniz must have been aware of the importance of recursion, when he emphasized the process of *repetition*.

11. A Program has a Structure with many Layers

Getting back to *Monadology*, let me speak for a while in the *ideal* (“as if”) mode without inserting this qualification, for the sake of brevity, in order to talk about “communications” among monads. I have already said that matter is infinitely divisible, and this implies that there are *infinitely many sub-layers* within a body. An organized body (or organism, for short) is often called “natural or divine machine,” and since it is governed by a monad called “*anima*” (or soul), it is also called “animal.” Further, recall that any such natural machine or animal is the “result” of an organization of innumerable monads. Each of such monads *must* be *individually* programmed by God, *in view of* the whole organization, and this is the pre-established harmony. I have been surprised that very few (if any) Leibniz-scholars are aware of the close connection between *machines* and *automata*; presumably because they are not interested in the theory of information.

Many layers and *organized*: this certainly produces a *hierarchy of programs*. That is, there must be, on the top, the program of the monad which governs the whole organism, and under this, many and various programs or subprograms follow, *ad infinitum*. Needless to say, these programs correspond, respectively, to the *transition functions* of those monads which are the source of the whole organism.

Strictly speaking, program and transition function must be distinguished: a program is a *sequence of instructions* for *realizing* the corresponding transition function; the same transition function can be realized by several different programs, especially when the programmer uses different coding. But we may often use these two words, “program” and “transition function,” interchangeably, when there is no danger of confusion. In information theory, any (finite) automaton governed by a transition function can be described in terms of a corresponding program. And as I have explained in Section 10, even an infinite automaton, such as Turing machine (with unlimited tapes), can be identified with its program, for most purposes (the general nature of infinite automata is not clear to date).

Now we have been concerned with the distinction between *active* and *passive* in *Monadology*. I suggest that there may be several different ways to define the distinction between active and passive, based on the preceding *hierarchy of programs*. But the most straightforward way would be: basically, if a program (in the whole) is subordinated to another as a *subprogram*, it may be called *passive* and the other *active*, and the same is true of each monad corresponding to these programs. This distinction is of course *relative*, so that, e.g., program *A* may be active relative to *B*, but passive relative to *C*. Moreover, this distinction *depends on context*; a

program P may contain a subprogram Q , but P may also appear in Q ; i.e., *recursion* occurs (often, as in our computer programs). For example, as we have seen in Section 10, there is a program I which *iterate* a subprogram S a specified number of times, which is expressed as $I(S)$. Namely, if we apply this program to number n , this program repeats S , n times. Thus it roughly says, in our ordinary language (since instructions are expressed in imperative mood), “ S , you repeat your job n times.” The important technical point is that the *procedure* of I is *exactly the same*, even when it is applied to any natural number (i.e., the program, which is *a series of instructions*, does not change at all).

Now we come to the crucial point: S can be $I(S)$ itself, so that $I(I(S))$ is meaningful; this is *recursion*. Thus, according to my proposal, the master program, outer I is active, and subprogram $I(S)$ is passive; this *contextual dependence* is all right, because a program can have a *recursive* structure. Despite the fact that Leibniz did not use the word “recursion,” he was well aware of this, as we will see shortly.

Although this proposal works only within individual organic body, it can capture at least some important aspects of Leibniz’s distinction. For a program imposes a certain task to several subprograms under its control; so that “an *a priori* reason” why any subprograms are doing what they do, can be given by that program. Above all, the *anima* of an organism is a “miniature” of God, in that it unifies the whole, the *most perfect* in that organism. If we may use an analogy in terms of an animal (like dog, cat, or human), it can have *most distinct perceptions* of the external world, despite the fact that many physical, physiological, and unconscious processes are underlying such perceptions in consciousness; here I am assuming that the governing program reside in consciousness (this seems to be close to Leibniz’s own view, since he called such a governing monad *anima* or *soul*).

And finally, let me add that Leibniz himself was aware of the *recursive structure* in the organized monads, although he never used such words as “recursion” or “recursive function.” As a strong evidence for this claim, let me quote this (*Monadology* section 67, Ariew and Garber 1989, 222):

Each portion of matter can be conceived as a garden full of plants, and as a pond full of fish. But each branch of a plant, each limb of an animal, each drop of its humors, is still another such garden or pond.

Many readers may regard this as a poetic metaphor. It is poetic, all right. But its content is perfectly *logical* also, in that Leibniz is here suggesting that the infinite divisibility of matter corresponds to the *recursive structure* of an organization of

monads, the recursive structure of the program and subprograms governing such an organization! Thus this poetic quotation strongly supports my informational interpretation of *Monadology*.

12. Divine Machines and Cellular Automata

It may be instructive to try this interpretation from another perspective, in order to see how Leibniz's other key words may fit in this interpretation. Besides, some appropriate way to handle *communications* among many bodies may be suggested in our discussion.

Suppose we are focusing on the *flow of information* in an organism; this flow must be reflected in the hierarchy of programs. Borrowing one of Leibniz's favorite examples, the "roar of the sea," we perceive that great noise, roughly as follows. Each of innumerable waves raises a small noise, and all of such noises reach our body (ears, in particular) and a bunch of complex processes will go on. At some stage, what Leibniz calls "petites perceptions" (minute perceptions) appear. Our *anima* cannot recognize them, but their overall effect is the "roar of the sea," which everyone can perceive, although no one can *distinguish* the sound of each wave, except for a few large ones. Thus the roar is a confused perception. However, only the *anima* can have this perception, presumably, neither our body, nor any organs in our body can, including ears. Nevertheless, that perception is a product of the works made by various *subprograms* (in the ears and other organs in our body).

In this example, the (external) information flows from each waves to our ears, and finally to our *anima*. Now suppose there are a thousand of observers in various locations on the sea, concentrating on a few waves and listen to their sound. Each of these observations are certainly more distinct! Then, these observations, which may be regarded as corresponding to our *minute perceptions*, may be in *some sense* more distinct than our perception of the roar. But when these noises reach us on the shore, our perceptions are confused. This shows that, as far as the *flow of information* is concerned, more distinct perceptions become less distinct, as it propagates to a *distant* place (also it take *time*); so that it may be misleading to say that distinctness is a good mark for attributing *activity*. That's one of my reasons for invoking the structure of program, in order to distinguish activity from passivity.

This is a story of the flow of information in our *phenomenal* world. However, Leibniz says similar things even as regards *monads* governing organisms.

... although each created monad represents the whole universe, it more distinctly represents the body which is particularly affected by it, and whose entelechy it constitutes. (*Monadology*, sect. 62, Ariew and Garber 1989, 221)

And notice that in the realm of monads, *there is neither spatial distance nor temporal duration*. Then, why is there this difference of the body of a monad and the rest of the world, in the monad's perceptions of them? In the realm of monads, the flow of information may have no constraints comparable with that in the phenomenal world. This question may lead us to a surprising discovery in our interpretation of Leibniz's physics and metaphysics.

Leibniz's answer to this question would be something like this (with free paraphrasing in modern terms): the *anima* of a given body *controls* the body by its program (and hence *active*), but not waves or their sounds, which do not belong to the body; this difference comes from God's organization of monads. In short, the reason for the limited capacity of perception is: aside from the limitation of created monads themselves, God's *organization* of the monads in terms of *various units*, each of which has one entelechy governing its body (corresponding to a collection of other monads, in reality). Each monad is programmed, but *in each unit*, there is a definite hierarchy of these programs.

There should be various connections between waves and people on the shore, but neither water nor people can have any distinct perceptions of such connections. Only God can take care of this matter. But, here, we have to remember Leibniz's consistent view of *plenum*, that *vacuum* cannot exist and the phenomenal world is filled with matter without void. This means that, in the case of our perception of the roar of the sea, when each sound of wave travels to our ears, its path is completely filled with *other bodies* of various kind. What are these bodies? They are of course *bodies each governed by an entelechy*, so that each of them corresponds to a group of monads organized in a certain way.

So, here is a surprising discovery (I pointed this out in my 2009 paper, Glymour, Wei, and Westerståhl 2009, 346)! John von Neumann proposed, around the middle of the 20th century, the notion of *cellular automaton*, in order to show that a self-reproducing automaton is possible. It is a larger automaton composed of many unit automata (they are "cells" as it were). Let me briefly explain. Von Neumann assumed a two-dimensional cellular space, where the same unit automata are arranged in an infinite grid-circuit, and each is connected with four neighbors. They shear the *boundary*, so to speak; inserting double arrows is only a manner of depicting, and they can be deleted, as long as the *relation of neighbor* is kept in mind. Thus, von Neumann's cellular space can be made into a *plenum*, with no vacant spot in it! According to von Neumann's original version, the unit automaton can have 29 states (but later researches reduced the number of states to a much smaller number). See Figure 6 (see also Burks 1970, 9; for a reconstruction of self-

reproducing automata in terms of Wang’s program version of Turing machine, see Thatcher 1970).

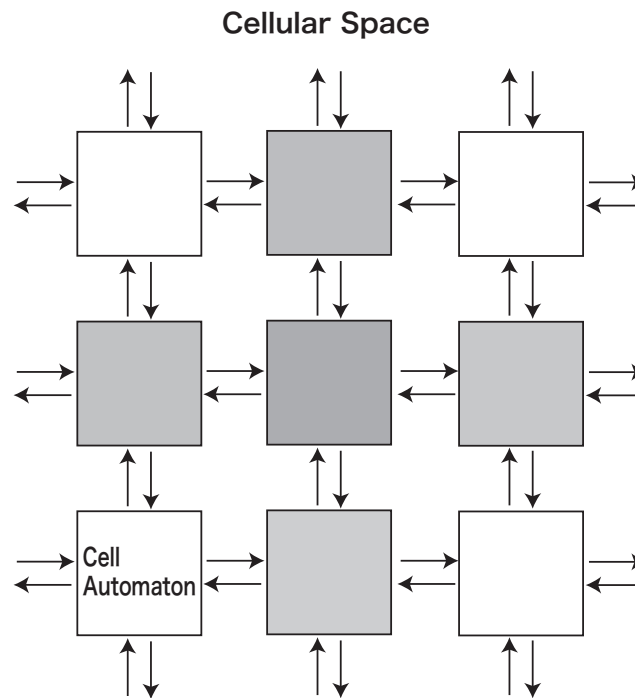

Figure 6: Von Neumann’s Cellular Space

Now, the point of a cellular automaton, i.e., an *organized* automaton from many unit automata in the cellular space, is that it can do various things, including universal computation and self-reproduction (a case of universal construction). Leibniz suggested basically a similar idea more than 300 years ago, although he did not have an appropriate word for that, except for “body,” or “corporeal substance.” His words are old-fashioned, but his idea is as new as von Neumann’s brilliant idea. And sometimes Leibniz uses other expressions, such as “divine machine” or “natural automaton” (*Monadology*, sect. 64, etc.), and this is another strong support for my claim. And you may see the importance of this idea that by *organizing* unit automata (monads, in Leibniz), we can make a *much powerful* automaton. In Leibniz, the whole world may be regarded as a *single cellular automaton*, both in reality and in phenomena, according to my interpretation.

Further, we can find many other texts which support my claim. In section 61 of *Monadology*, Leibniz’s discussion of the limitations of a monad is extended to “composite substances” (organized bodies, each governed by an entelechy). The limitations, i.e., that a monad can represent the whole universe, but since its perceptions can be distinct only for a limited portion, the rest of perceptions are confused.

In this respect, composite substances are analogous to simple substances. For everything is a plenum, which makes all matter interconnected. In a plenum, every motion has some effect on distant bodies, in proportion to their distance. For each body is affected, not only by those in contact with it, and in some way feels the effects of everything that happens to them, but also, through them, it feels the effects of those in contact with the bodies with which it is itself immediately in contact. (Ariew and Garber 1989, 221)

According to Leibniz, the phenomenal universe is filled with matter, divine machines, ether, etc., and each body has its *neighbors immediately in contact*. And he is saying that communication between bodies are made through their boundaries (which must be two-dimensional surfaces); the information from distant bodies can be transferred by a chain of such immediate contacts. Thus he is in effect suggesting that the universe is filled with innumerable *cells* (some are large, and maybe each is a divine machine), and such cells communicate through their boundaries. The seemingly vacant space is filled with ether (see Figure 7, which is nothing but a crude sketch. Each body, or “cell,” shares boundaries with many neighbors in the plenum). Hence, according to Leibniz, the actual space is a “cellular space,” so to speak. Therefore, he is certainly qualified to be called the first proponent of “cellular automata,” although the honor of working out the details goes to von Neumann.

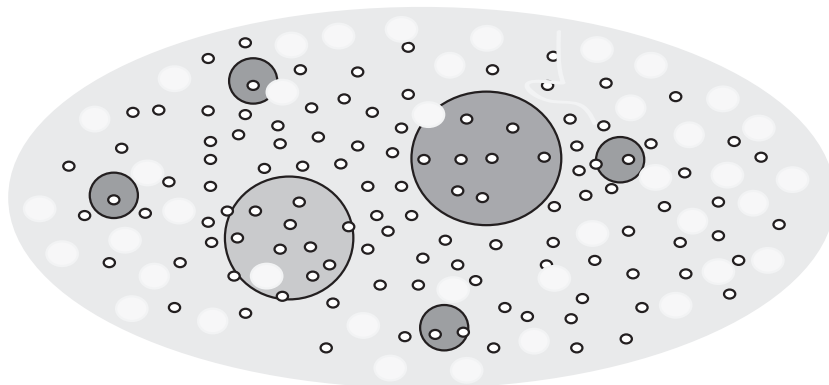

Figure 7: Leibniz's Cellular Space

Moreover, Leibniz supported this picture by his metaphysics of monads. God organized monads into groups, and these groups are the basis of cellular automata in the phenomenal world. Thus, Leibniz *doubly* utilized the notion of cellular automata, in reality and in phenomena.

Let me finish my discussion of cellular automata. As I have already quoted, Leibniz, in section 62 of *Monadology*, said that “although each created monad represents the whole universe, it more *distinctly represents* the body *which is particularly affected by it*” (this time, my own italics). The comparison here is between the monad’s perceptions (representation) of the “whole universe” and of “the monad’s body,” but the same can be said of the monad’s perceptions of *any bodies other* than its own. As I understand, although Leibniz here seems to be talking about *distinct perceptions*, he is rather stating the *reason why* its perception of its own body is *more distinct* than other representations (of universe, of other external objects). That reason is the second italicized phrase. Namely, the monad *particularly affects* its body; *because of this close relation*, the monad represents its body *distinctly*. In my own words: the monad (or its program) *controls* the body (or its program, and through it, all of its subprograms), and hence distinctly represents it. The monad’s program is not only its own program, but also the dominant program of the *whole cellular automaton* composed of itself and its body.

Now let us remember that, from Section 9, we have been dealing with the distinction between “active and passive” in *Monadology*. Our discussion is still incomplete, but I think I have shown so far that my interpretation of the distinction is promising. In terms of the relation of a program and its subprograms, we can take care of “a priori reasons” Leibniz evoked, and also of “distinct/confused” perceptions, even giving a *reason* for that distinction. What remains is the relation of “act on” and “to be acted on,” which seems particularly relevant to dynamics.

13. Relativity of Action and Passion, based on Recursion

In order to discuss the details of one monad acting on another, and of the latter being acted on by the former, I wish to make clear my assumptions for the whole discussion.

First, I assume that *the information of the monads* (individually and taken together) is *conserved*, this being Leibniz's own assumption, although it is hard to find any explicit statement on this (because he did not use the word "information").

However, since the world of monads must be conserved unless God decides to annihilate it, the transition functions (programs) of the monads must be preserved as long as the real world exists.

Second, I assume the *primitive force* is another name of the essential part of the information contained in a monad (remember that the monad is given at once, including *all its changes*). But what is essential? None other than the *transition function* (realized by its program) of the monad; for, given the initial state (perception) of a monad, everything is determined by that function. And, in order to avoid tedious expressions, I say "transition function" for expressing the whole series of a monad's states, which is equivalent with "the transition function plus the initial state." But recall that the primitive force consists in the *active force* (from the entelechy) and the *passive force* (from the primary matter).

Third, therefore, I assume that the transition function is concerned *both* with *active* and *passive forces*. This may look a truism, but worth mentioning, since some people may misunderstand that only active force is involved in any change. But, of course, in order to change a state (perception) of any monad, all monads must be involved, and in the change of that state both action and passion are necessary, since "acting on" presupposes something "to be acted on." Remember that both elements (expressed in phenomena, i.e., derivative forces) are contained in *impetus* (mv or its infinitesimal element) as well as in *living force* ($mv^2/2$). If we neglect this point, Leibniz's dynamics (which is subordinated to metaphysics) may become unintelligible!

And fourth and finally, I assume "the transition function of a monad" and "the program of that monad" (together with its initial state) are equivalent, despite my previous remark, since from now on, we will be talking about *God's programs*. Although there can be a number of different programs for realizing the same transition function, God will choose the *optimal* program together with his *coding*. Thus we have *no* need for considering any other *possible programs*. However,

depending on contexts, we will often exchange one word for the other; when we wish to make explicit the current *state* of a monad, transition function is more appropriate, and when we wish to point out recursion, program may be more appropriate. And in this connection, we will introduce the following symbolism for expressing a state-transition of monad:

- (1) $f([x])=[x']$: the transition function f is applied to the current state $[x]$, and the next state is $[x']$. (NB, “next” does *not* imply time; it only means *order* in the *given series of all states*, hence I adopted the symbol usually employed for the “successor” of a natural number)
- (2) Alternatively, we may simply write: $[x] \rightarrow [x']$
- (3) Further, we may express the n th successor as $[x^n]$.

With these preparations, let us examine the consequences from my interpretation of “active/passive” in terms of the hierarchical structure of programs. We can easily see the *relativity* and *contextual* character of this distinction. To repeat the example of the program of iteration $I(P)$, I is active relative to another program P in this context, but if we find the same program I within the context of P , where I is acting on another program S , thus P containing as part $I(S)$, I is active relative to S but passive relative to P ; $I(I(S))$ is a particularly clear example, in that the outer I is active whereas inner $I(S)$ is passive relative to the outer. It is clear that this trick is made possible by *recursion*. And this seems quite in conformity with what Leibniz says in the text of *Monadology*. According to the terminology of “act on” and “to be acted on,” I act on P in the context of $I(P)$, but I is acted on by P when I appears as a subprogram of P .

However, we have to be very careful here. Leibniz is talking about interactions between two *monads*, and we *do not know* whether or not such programs as I or P above represent the program of a monad. So we may have to switch to “transition function.” On the other hand, however, Leibniz often reminds us of the *ideality* of any relations among monads. When he says “one monad acting on another,” this is only a manner of speaking for describing what happens *within* the perceptions of a single monad. Because of the pre-established harmony among the monads, every monad represents the whole universe in its own way, and this is *solely* governed by its own program or transition function. Thus, there is a perfectly legitimate manner of speaking that a program “acts on its subprogram” or “being acted on by another.” And in every monad, the whole universe is represented as a series of perceptions (many are confused, though), i.e., all values of $f([x])$, $[x]$ running from the initial state *ad infinitum*, which I stipulated to call its “transition function”; this is what we always have to keep in mind.

And now, let me remind the reader of the following important passage from section 61 of *Monadology*:

every body is affected by everything that happens in the universe, to such an extent that he who sees all can read in each thing what happens everywhere, and even what has happened or what will happen, by observing in the present what is remote in time as well as in space. (Ariew and Garber 1989, 221)

Let us call this person, "he who sees all," *Leibniz's demon*. Notice that Leibniz's demon appeared *well before* the famous demon described by Laplace, and much stronger than it! Leibniz's demon is *logically possible*, because all monads together with their transition functions are given *at once*, with the *pre-established harmony* among them.

However, I have to point out here, that this demon has to know *God's coding* also, in order to know how reality and the phenomena correspond to each other. Reading the phenomenal information contained in a body, is not sufficient for reconstructing the *program* in the monads (reality), and unless you know *God's coding*, you can neither know this program nor the whole history of the world. You can clearly see this point, as soon as you recall a Turing machine. Unless you know how numbers are *encoded* on the tape, you cannot *decode* a bunch of marks on the tape!

With this proviso in mind, we may revise or extend, the preceding statement of the demon. Namely, we can say that by examining the *program of a single monad*, the demon can know the whole history of the world, reality and phenomena. This justifies me for continuing the preceding manner of speaking, about action and passion, in terms of programs, in order to see more of its consequences.

14. Recursion in the Phenomena

Then, in view of this, what can we say about *derivative forces* in the phenomenal world? Obviously, such relativity and contextual dependence must be somehow reflected in dynamics. So let us reexamine Leibniz's dynamics in view of my interpretation of "active/passive."

First, take an inertial motion with velocity v . For Leibniz, "absolute velocity" does not make sense, and hence this v is only nominal. A more serious problem is that we cannot discuss any motion without *something* which has a velocity. Thus we have to assume some *body* with mass m , and as soon as we introduce a body, we have to take passive force contained in that body into consideration. And as I have already made clear in Section 4, Leibniz has a good reason, given his metaphysics and *analysis situs* (qualitative geometry), to assume an active force working even in this inertial motion. Therefore, at any instant of motion, there is an infinitesimal *impetus* (or *nisus*). But, of course, *impetus mv* is an amalgamation of active *and* passive, and so is its infinitesimal element. An active (derivative) force striving toward change is represented by v , a passive (derivative) force resisting this force is represented by m (including the degree of resistance), and the result is represented by the product mv , and this balanced state (i.e., a linear uniform motion) *persists* unless further changes are added by some means. In short, an inertial motion *must* be described in terms of *both* active and passive derivative forces.

Now, with this simple example of inertial motion, where are the relativity and contextual character of "active/passive" reflected? First of all, an inertial motion has to be placed within the *context* of the whole (or a larger portion) of the phenomenal world. However, it is not clear how Leibniz would treat "the whole phenomenal world," and his dynamics remained incomplete. This problem is later taken up by Ernst Mach, and other proponents of relationalism (see Barbour and Pfister 1995). Secondly, since "the velocity of a motion", taken by itself, is meaningless, it must be replaced by a *relative* velocity, as was actually done in Leibniz's treatment of collisions. And in this context, Leibniz introduced the distinction of total and partial living force (Section 8). This means that our *nominal* velocity v of the inertial motion is a dummy, and *impetus mv* also contains the same dummy. However, in the context of a collision (of two bodies with respective inertial motions), such dummies can be replaced by meaningful quantities in *that context*, depending on the center of common gravity. If we wish to treat collisions *within* a body, we have to change the context (corresponding to smaller bodies within that body), and this time, the center of gravity is of the *single whole body*, different from the previous one.

Thus, although Leibniz has never completed his dynamics, he has at least shown how to apply his dynamics to specific problems contained in a *given context*. And, to be fair, the same must be pointed out as regards Newton's mechanics; he and his followers applied his mechanics by setting a certain context, extracted from the *unknown whole*, and were in no better position than Leibniz's. In a similar way, Leibniz's dynamics remained incomplete and unsystematic. But this is an inevitable consequence of Leibniz's metaphysics. Because, obviously, Leibniz could not spell out the *program* of the monads; he merely suggested or sketched the recursive structure of that program, according to my interpretation. But his idea that a monad is an incorporeal automaton governed by a transition function is really amazing. Thus even the preceding sketch is a striking novelty, in spite of his "old-fashioned" terminology. Moreover, he could at least show a *good vision* for dynamics, because, for him, the major changes of motion are due to *collisions*. In other words, most of the *interactions* among phenomenal bodies are described in terms of collisions.

And elastic collisions are *repeated* at every layer of the infinite divisibility of matter, from the level of planetary motions, action of gravity on the earth, centrifugal forces, collisions of billiard balls, deformation of a body, rebounding, etc., etc., *ad infinitum*. I suspect he might have considered the whole phenomenal universe as an *elastic machine*, so to speak, trying to explain gravity in terms of elasticity of ether, the ubiquitous matter filling the universe, together with other bodies.

So, here is another new discovery. In the preceding simple analysis, we can notice that the *same recursive structure* reappears! The program of an entelechy, as well as an organized collection of monads, has a recursive structure, as we have seen. And the same structure reappears in dynamics, which deals with motions in the phenomenal world. Thus, Leibniz's claim that a partial correspondence or homomorphism holds between reality and phenomena, is at least partially justified.

Leibniz says that we should describe the motion within dynamics without appealing to metaphysical concepts. However, if we wish to explain why the laws of dynamics hold in the phenomenal world, we have to appeal to metaphysics. Why do active and passive derivative forces collaborate in such ways as described above? Leibniz's general answer is: because the program of the body (of the preceding inertial motion) is enacted by the entelechy governing that body. All right, then, how does this program work? Thus we have to go into *some details* of the program.

For this purpose, let us introduce the notion of the “collective state” of a group of monads, and the “common force” of the same group. This group is the source of a body in the phenomenal world. And the *collective state* corresponds to an *instantaneous place* (with some extension) of the body in the phenomenal situation, relative to all other bodies (recall that Leibniz’s dynamics should be relational). The *common force* is nothing but the portion of the collective forces of the monads in the group, contributing to the *change* of the group taken *as a whole*. This is an adaptation of Leibniz’s distinction of living force between *total* and *partial* (further divided into *proper* and *common*), in Section 8. Notice that the “common resistance” (passive force) is already taken into consideration, since “force” includes two kinds, active and passive.

With this preparation, the transition function (the relevant portion, as far as this motion is concerned) of the governing entelechy prescribes, for an *inertial motion*, like this:

(1) Common force, you strive for such-and-such *change of the collective state*; and continue the *same change* until a new instruction comes.

Notice that this instruction is “translated” within the language describing phenomena; we do not know God’s coding, so that we cannot describe the program of a monad! However, we can at least point out that there must be, in the program of the dominant monad, a program corresponding to (1), written in God’s language. On this point, Leibniz’s explanation to Wolff (9 July 1711, Gerhardt 1860, 138) is quite helpful; this explanation is translated in Adams (1993, 385) as follows:

You ask how the primitive force is modified, for instance, when the motion of heavy [bodies] is accelerated by falling. I reply that the modification of the primitive force that is in the Monad itself cannot be explained better than by expounding how the derivative force is changed in the phenomena.

Thus, my rendering such as (1) is not off the mark. Leibniz is saying that by analyzing dynamic change, we can approach an explanation of the modification of the monad’s force. And this is, according to my interpretation, nothing but an inference as regards how the monad’s *program* is going on.

The reader should keep in mind that the “change” in (1) corresponds (in the phenomena) not to change of velocity but to *change of place*; Leibniz’s (relational) definition of “place” is given in his 5th paper of the correspondence with Clarke (see Alexander 1956). That is, his dynamics must be understood within his own

framework of space and time; but unfortunately, his theories of dynamics and of space and time were incomplete.

Another remark we have to add is that the preceding instruction (program) must be understood as a “result” of a multitude of subprograms governing each part of the body; the entelechy of the body controls these subprograms and extract such a “result” as the preceding, by its *interactions* (i.e., action and passion) *with* the subprograms.

And further notice that this instruction is *repeated* at every moment, and in the monad in reality, the corresponding instruction (relevant part of its program or transition function) is *repeated* (not in time but it operates in succession). This is already a sort of *recursion*. And, here, we can clearly see that an important problem of *coding* is lurking. *Non-quantitative* successions of state in a monad must be transformed into *quantitative and continuous* successions in phenomena. In other words, how can Leibniz solve the problem of *metric* of time? The same problem appears for space (extension) too. Although I will postpone these questions until I begin to discuss Leibniz’s view on space and time, one thing is clear. The problem of *metric* in the phenomenal world is *inseparable from God’s coding*. Here is another crucial reason why we have to emphasize the mediation of coding. (Later, I will argue that this is the key for seeing the relevance of Leibniz’s dynamics to Einstein’s special relativity, which holds in *inertial* or Lorentzian systems. The Lorentz metric of relativity (in Minkowski space) *can* be reconstructed within Leibniz’s dynamics, provided that God’s coding is arranged appropriately.)

However, although this program for inertial motion is important, it is less important than the program for *collision*. For Leibniz’s dynamics, collisions are far more important as an *interaction* between bodies, reflecting the corresponding interaction (even though *ideal*) between programs and between monads. Therefore, collisions are the *major part* of the source for knowing the activities of monads. And I will argue that, since collisions occur at every stage (layer) of the *infinite divisibility* of matter, they *recur* infinitely, forever. Thus, this *recursion* nicely reflects the *recursion in the program* of a monad.

15. Collisions and Programs

Let us turn to the problem of a collision anew. In view of the program for inertial motion (Section 14, (1)), how does the program for collision look like? Because of Leibniz's view of collision (Section 6), we may concentrate on the program of one body. Although a collision does provide an occasion of the changes to follow, the process each body undergoes is governed by *its own forces* so that the program of this process can be described *independently* from (but connected with) the other's program (this is an instance of the pre-established harmony). Its program may look like this:

- (1) On a starting signal (beginning of a collision), begin deforming the whole body, until the relative velocity (viewed from the common center of gravity) becomes zero. Then, begin the process of recovery and rebound, until the elastic force is completely released. And continue the resulted inertial motion.

Again, this instruction is translated in the language for phenomena, and supported by innumerable subprograms of the parts of the body. And in spite of this limitation, (1) can give a good starting point for reconstructing the original programs of the corresponding group of monads. The crucial point is that this program (1) *recurs* again and again, at *every layer* of the structure within the body. This recursion must have a counterpart in the programs of monads, which are the real source of this body in the phenomena.

Moreover, for Leibniz, centrifugal force, gravity, etc. are *all* utilizing the same, or similar, program as (1), since any interaction between bodies (including such fluid as ether) must be an elastic collision. Such interactions in the phenomenal world is endless, but the reason why they are endless can be explained by his metaphysics, i.e., *Monadology*. The following chain is repeated again and again, at every layer of matter:

impetus (of the relative velocity of collision) → collision → *deformation*
(impetus changing into dead force) → *recovery* from the deformation (dead force transformed into infinitesimal impetuses) → eventually leading to a *new impetus* of the whole body

Corresponding to this chain, in the program of the *entelechy* governing a body, the dominant program *acts on* subprograms, and they *are* in turn *acted on* by it, and such

reciprocal relations *recur* again and again, in every lower layer of the subprogram. Thus, although Leibniz never used the word “recursion,” *we* can see that recursion is at the *center* of both of Leibniz’s dynamics and metaphysics. And if we grasp this, we should have a better understanding of his famous passage:

each simple substance is a perpetual, living mirror of the universe.
(*Monadology*, section 56)

We now understand that the metaphor of “mirror” is Leibniz’s favorite way to express *recursion*: that a monad represents the whole universe, which contains that monad, and that the monad can, as a mirror, represent that all monads (including itself) can represent the universe, etc., etc., *ad infinitum*. Here, we can see an infinity of recursion. And because of the preceding correspondence (of recursion) between the reality and the phenomena, an anima *can know* something (at least) about the reality by examining phenomena.

(To be continued, to Part 2)

Bibliography

- Adams, R. M. (1994) *Leibniz: Determinist, Theist, Idealist*, Oxford University Press, 1994.
- Aiton, E. J. (1985) *Leibniz, a Biography*, Adam Hilger, 1985.
- Alexander, H. G., ed. (1956) *The Leibniz-Clarke Correspondence*, Manchester University Press, 1956.
- Ariew, R., and Garber, D., tr. and ed. (1989) *G. W. Leibniz Philosophical Essays*, Hackett, 1989.
- Barbour, J. B. (2000) *The End of Time*, Phoenix, 2000.
- Barbour, J. B. (2001) *The Discovery of Dynamics*, Oxford University Press, 2001.
- Barbour, J. B., and Pfister H., eds. (1995) *Mach's Principle*, Birkhäuser, 1995.
- Bertoloni Meli, D. (1993) *Equivalence and Priority: Newton versus Leibniz*, Clarendon Press, Oxford, 1993.
- Burks, A. W., ed. (1970) *Essays on Cellular Automata*, University of Illinois Press, 1970.
- Davis, M. (2011) *The Universal Computer, Turing Centenary Edition*, CRC Press, 2011.
- De Risi, Vincenzo (2007) *Geometry and Monadology: Leibniz's Analysis Situs and Philosophy of Space*, Birkhäuser, 2007.
- Earman, J. (1989) *World enough and Space-time*, MIT Press, 1989.
- Einstein, A. (1905a) "On the Electrodynamics of Moving Bodies," *Annalen der Physik* 17, reprinted in the *Collected Papers of Albert Einstein* 2, 140-171.
- Einstein, A. (1905b) "Does the Inertia of a Body depend upon its Energy Content?" *Annalen der Physik* 18, reprinted in the *Collected Papers of Albert Einstein* 2, pp. 172-174.
- Garber, D. (1995) "Leibniz: Physics and Philosophy," in Jolley (1995), 270-352.
- Garber, D. (2009) *Leibniz: Body, Substance, Monad*, Oxford University Press, 2009.
- Gerhardt, C. I., ed. (1860) *Briefwechsel zwischen Leibniz und Christian Wolff*, H. W. Schmidt, 1860.
- Gerhardt, C. I., ed. *Die Philosophischen Schriften von Gottfried Wilhelm Leibniz*, 7 vols., Weidmann, 1875-1890.
- Jolley, N. ed. (1995) *The Cambridge Companion to Leibniz*, Cambridge University Press, 1995.
- Loemker, L. E., tr. and ed. (1969) *Gottfried Wilhelm Leibniz, Philosophical Papers and Letters*, 2nd ed., Kluwer Academic Publishers, 1969.
- Mach, E. (1960) *The Science of Mechanics*, Open Court, 1960.
- Mates, B. (1986) *The Philosophy of Leibniz: Metaphysics and Language*, Oxford University Press, 1986.
- Rescher, N. (1991) *G. W. Leibniz's Monadology*, University of Pittsburgh Press, 1991.
- Rutherford, D. (1995a) "Metaphysics: The Late Period," in Jolley (1995), pp. 124-175.

- Rutherford, D. (1995b) *Leibniz and the Rational Order of Nature*, Cambridge University Press, 1995.
- Smith, J. E. H. (2011) *Divine Machines: Leibniz and the Sciences of Life*, Princeton University Press, 2011.
- Smith, J. E. H., and Nachtomy, O., eds. (2011) *Machines of Nature and Corporeal Substances in Leibniz*, Springer, 2011.
- Thatcher, J. W. (1970) "Self-Describing Turing Machines and Self-Reproducing Cellular Automata," in Burks (1970), 103-131.
- Turing, A. (1936) "On Computable Numbers, with an Application to the Entscheidungsproblem," *Proceedings of the London Mathematical Society*, ser. 2, 42 (1936), 230-267.
- Uchii, S. (1989) *Truth, Proof, and Computation: Logic and Machine* (in Japanese), Kyoto: Minerva, 1989.
- Uchii, S. (2004) *Tracing Einstein's Ideas—Introduction to the Philosophy of Space and Time* (in Japanese), Kyoto: Minerva, 2004.
- Uchii, S. (2006) *The Riddle of Space and Time* (in Japanese), Chu-ko Shinsho, 2006.
- Uchii, S. (2009) "An Informational Interpretation of Monadology," in *Logic, Methodology and Philosophy of Science, Proceedings of the 13th International Congress* (ed. by Clark Glymour, Wang Wei, and Dag Westerståhl), College Publications, 2009, 344-353. (Pdf version, <http://philsci-archive.pitt.edu/4635/>)
- Vailati, E. (1997) *Leibniz and Clarke*, Oxford University Press, 1997.
- Wang, H. (1957) "A Variant to Turing's Theory of Computing Machines," *Journal of the Association for Computing Machinery* 4, 1957.